

**Zero Motocycles**  
**FX 2017 Exploded Views**

ZEV0038 - Frame(Right)

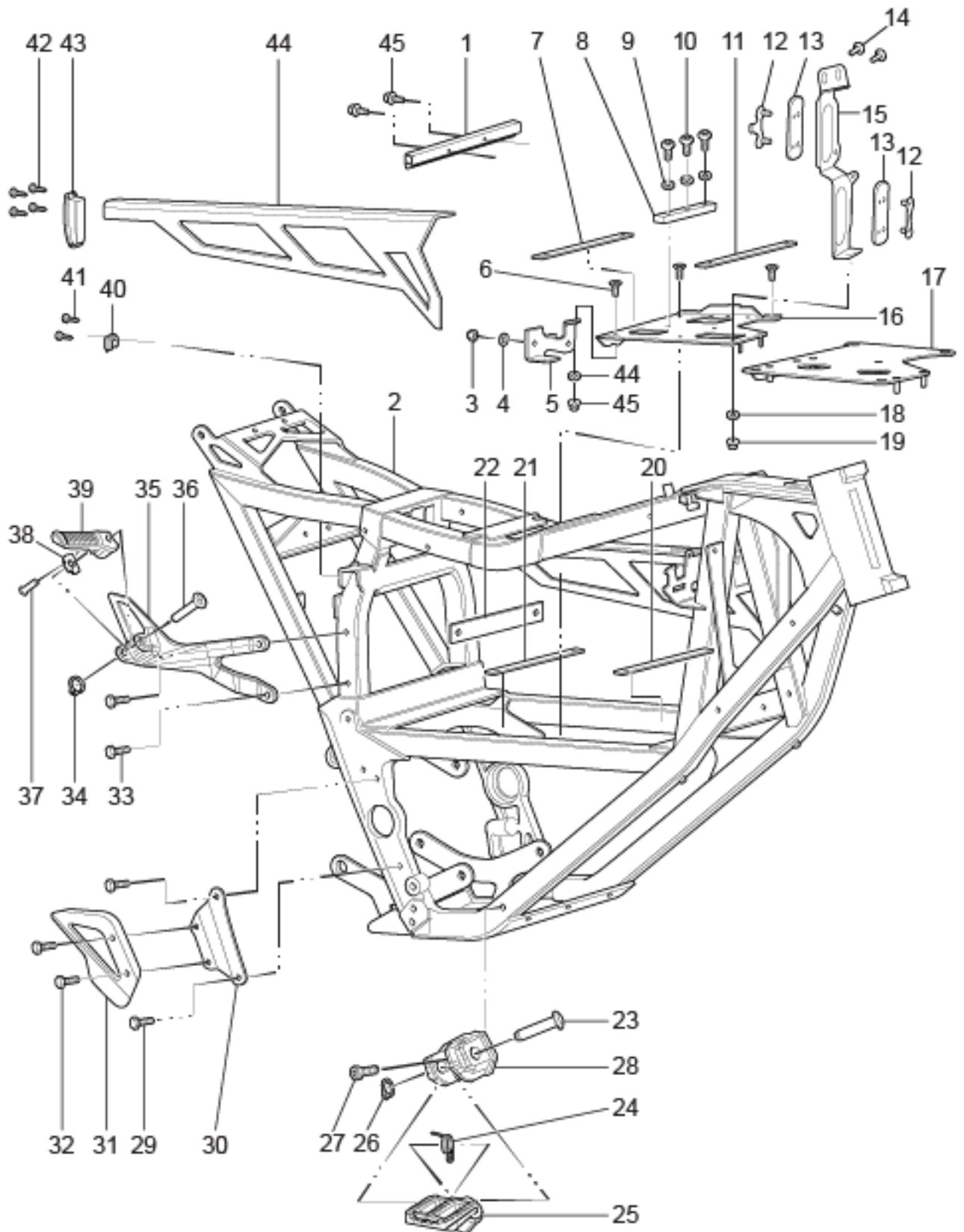

**ZEV0038 - Frame(Right)**

Callout	Part Number	Part Name	Qty. per Motorcycle
1	26-08140	ELECTRICAL MOUNTING BRACKET XMX REAR UPPER LONGBRICK	1
2	26-08080	FRAME XMX COMPLETE ASSEMBLY WITH RAIL AND BEARINGS NOTE: Must supply VIN# and Warranty Claim# when ordering. NOTE: Supersedes part number 20-07479.	1
3	90-02052	PREVAILING TORQUE TYPE NUT DIN 985 M4-08 ZM-F-01 REV 03	1
4	90-02102	WASHER UNIVERSAL (SIZE 1)	1
5	20-06862	MOUNT BRACKET AUX CHARGE XMX	1
6	90-05244	HEXAGON SOCKET COUNTERSUNK HEAD SCREW ISO 10642 M5X12-10.9 ZM-F-01 REV 03	1
7	20-05773	MODULE SLIDER GENERAL	1
8	20-05153	MODULE SEPERATOR BLOCK	1
9	90-02101	WASHER ISO 7089 5-200HV ZM-F-01 REV 02	1
10	90-07272	HEXAGON SOCKET BUTTON HEAD CAP SCREW ISO 7380 M5X8-8.8 ZM-F-01 REV 03 ZM-L-02 REV 01	1
11	20-05774	MODULE SLIDER FRONT MODULE HORIZONTALS	1
12	20-05286	COMPLIANT MOUNT RETAINER AND NUT PLATE	1
13	20-05109	BIKE SIDE COMPLIANT MODULE CONNECTOR MOUNT	1
14	PA-155	CAD PART NUMBER 90-02614	1
15	20-05912	BIKE SIDE MODULE CONNECTOR HOLDER COMPLIANT MOUNT	1
16	20-06863	XMX MODULE SUPPORT PLATFORM 14MY IMPL	1
17	26-08139	ELECTRICAL MOUNTING BRACKET XMX LONGBRICK SUPPORT PLATFORM	1
18	90-02103	WASHER ISO 7089 6-200HV ZM-F-01 REV 02	1
19	90-02054	PREVAILING TORQUE TYPE NUT DIN 985 M6-8 ZM-F-01 REV 02	1
20	20-05774	MODULE SLIDER FRONT MODULE HORIZONTALS	1
21	20-05773	MODULE SLIDER GENERAL	1
22	20-05773	MODULE SLIDER GENERAL	1
23	90-02725	CLEVIS PIN CUSTOM 10MM X 45L	1
24	20-02727	TORSION SPRING, .678 OD .078 WIRE, CCW	1
25	20-02549	FOOTPEG, RIGHT NOTE: Does not apply to S and SR	1
26	90-02879	RETAINING RING 9MM SHAFT	1
27	90-07277	HEXAGON SOCKET THIN HEAD CAP SCREW DIN 7984 M10X25-8.8 ZM-F-01 REV 03 ZM-L-01 REV 01	1
28	20-02724	CLEVIS FOOT PEG UNIVERSAL RIGHT	1

29	90-02094	HEXAGON SOCKET HEAD CAP SCREW ISO 4762 M8X25-10.9 ZM-F-01 REV 03	1
30	20-06295	REAR MASTER CYLINDER BRACKET XMX M6 THRU	1
31	20-06939	PASSENGER PEG BRACKET HEEL GUARD LEFT NOTE: USED ONLY ON EU FX	1
32	90-07323	HEXAGON SOCKET BUTTON HEAD CAP SCREW ISO 7380 M6X25-8.8 ZM-F-01 REV 03 ZM-L-01 REV 01	1
33	90-02613-9	SDS PASSENGER PEG BRKT L BOLT	1
34	90-02879	RETAINING RING 9MM SHAFT	1
35	20-07604	SDS AND FX PASSENGER PEG BRKT R	1
36	90-02725	CLEVIS PIN CUSTOM 10MM X 45L	1
37	20-05404	FOOTPEG DETENT BALL MECHANISM	1
38	20-04279	FOOTPEG DETENT PLATE	1
39	27-08038	PASSENGER FOOTPEG RIGHT SIDE	1
40	26-08180	LONG BRICK STORAGE BOX STRIKER PLATE	1
41	90-08099	FRAME RAIL LATCH SCREW	1
42	90-08099	FRAME RAIL LATCH SCREW	1
43	PA-232	BATTERY SIDE FRAME LATCH	1
44	20-06404	XMX BATTERY RETAINING RAIL NOTE: Rail does not include latch (20-05296), screws (90-06857), foam or ZF insignia, which are ordered separately.	1
45	90-04084	HEXAGON SOCKET BUTTON HEAD CAP SCREW ISO 7380 M5X16-8.8 ZM-F-11 REV 03	1



ZEV0037 - Frame(Left)

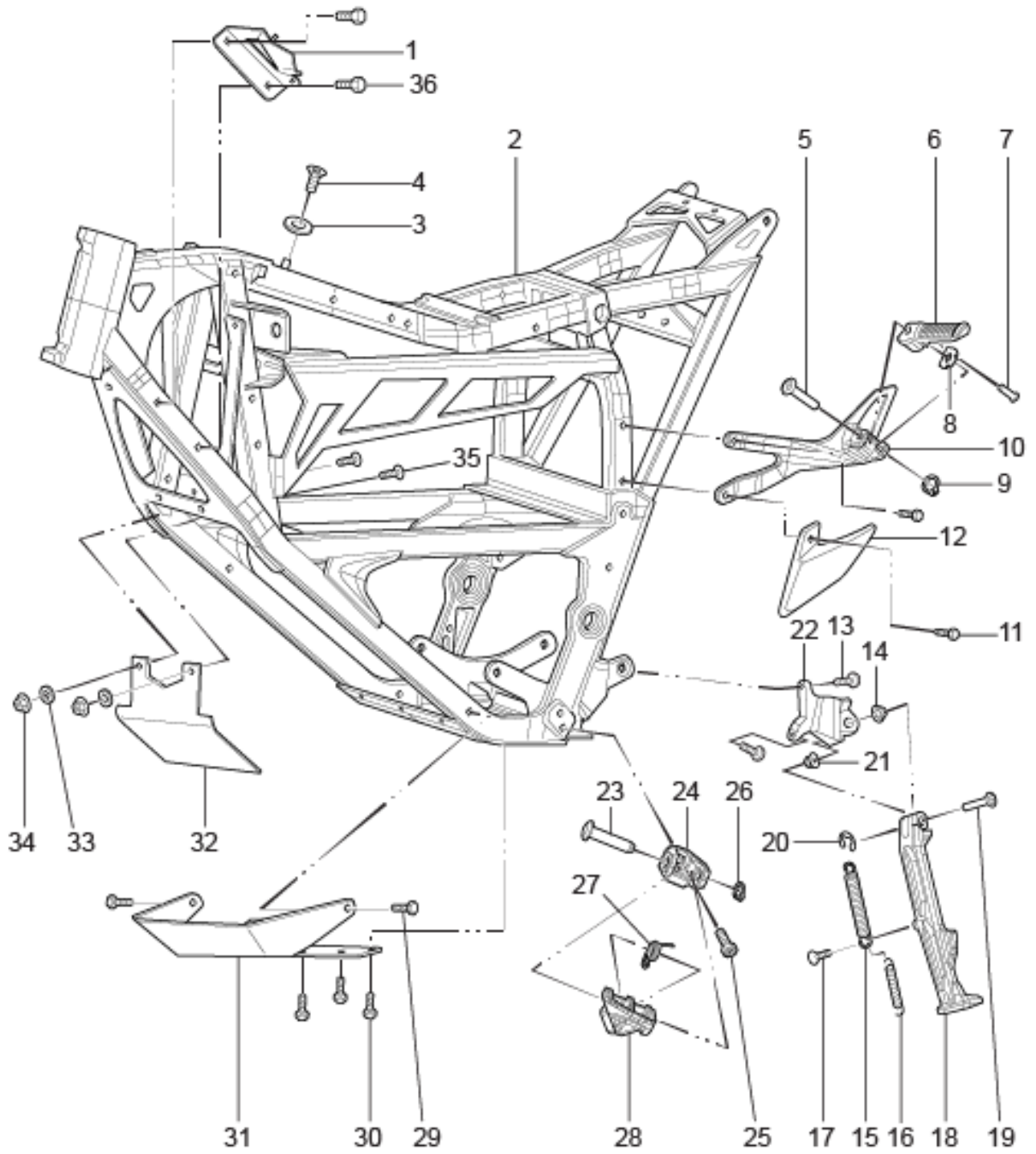

## ZEV0037 - Frame(Left)

Callout	Part Number	Part Name	Qty. per Motorcycle
1	26-08041	CHASSIS STRUCTURE MOUNTING BRACKET HORN	1
2	26-08080	FRAME XMX COMPLETE ASSEMBLY WITH RAIL AND BEARINGS NOTE: Must supply VIN# and Warranty Claim# when ordering. NOTE: Supersedes part number 20-07479.	1
3	20-06439	SEAT KNOB 14MY IMPL	1
4	90-02059	HEXAGON SOCKET COUNTERSUNK HEAD SCREW ISO 10642 M6X18-8.8 ZM-F-01 REV 03	1
5	90-02725	CLEVIS PIN CUSTOM 10MM X 45L	1
6	27-08037	RIDER FOOTPEG LEFT SIDE STREET	1
7	20-05404	FOOTPEG DETENT BALL MECHANISM	1
8	20-04279	FOOTPEG DETENT PLATE	1
9	90-02879	RETAINING RING 9MM SHAFT	1
10	20-04285	SDS PASSENGER PEG BRKT L	1
11	90-07284	HEX FLANGE BOLT M8X25	1
12	20-06939	PASSENGER PEG BRACKET HEEL GUARD LEFT NOTE: USED ONLY ON EU FX	1
13	90-07277	HEXAGON SOCKET THIN HEAD CAP SCREW DIN 7984 M10X25-8.8 ZM-F-01 REV 03 ZM-L-01 REV 01	1
14	90-02800	BUSHING FLANGE 0.375	1
15	20-00710	S KS SPRING OUT NOTE: Superseded by 90-08219	1
16	20-00709	S KS SPRING IN	1
17	90-07261	HEXAGON SOCKET COUNTERSUNK HEAD SCREW ISO 10642 M8X20-10.9 ZM-F-01 REV 03 ZM-L-01 REV 01	1
18	20-05662	LONG KICKSTAND LEG W/MAGNET	1
19	90-02799	CLEVIS PIN CUSTOM NOTE: Used to attach kickstand leg to mount.	1
20	90-02837	E CLIP 0.375	1
21	90-02800	BUSHING FLANGE 0.375	1
22	20-06590	KICKSTAND MOUNT	1
23	90-02725	CLEVIS PIN CUSTOM 10MM X 45L	1
24	20-02723	CLEVIS FOOT PEG UNIVERSAL LEFT	1
25	90-07277	HEXAGON SOCKET THIN HEAD CAP SCREW DIN 7984 M10X25-8.8 ZM-F-01 REV 03 ZM-L-01 REV 01	1
26	90-02879	RETAINING RING 9MM SHAFT	1
27	20-02727	TORSION SPRING, .678 OD .078 WIRE, CCW	1
28	20-02548	FOOTPEG, LEFT	1
29	90-02615	HEXAGON FLANGE BOLT DIN 6921 OR ISO 4162 M6X16 ZM-F-01	1

30	90-02615	HEXAGON FLANGE BOLT DIN 6921 OR ISO 4162 M6X16 ZM-F-01	1
31	26-08018	XX SKID PLATE HEAT SINK PROTECTION	1
32	20-05036	HEAT SINK MOUNT	1
33	90-02103	WASHER ISO 7089 6-200HV ZM-F-01 REV 02	1
34	90-02054	PREVAILING TORQUE TYPE NUT DIN 985 M6-8 ZM-F-01 REV 02	1
35	90-02059	HEXAGON SOCKET COUNTERSUNK HEAD SCREW ISO 10642 M6X18-8.8 ZM-F-01 REV 03	1
36	90-07285	HEXAGON FLANGE BOLT DIN 6921 OR ISO 4162 M5X16 ZM-F-01 REV 03 ZM-L-01 REV 01	1





ZEV0036 - Rear Suspension

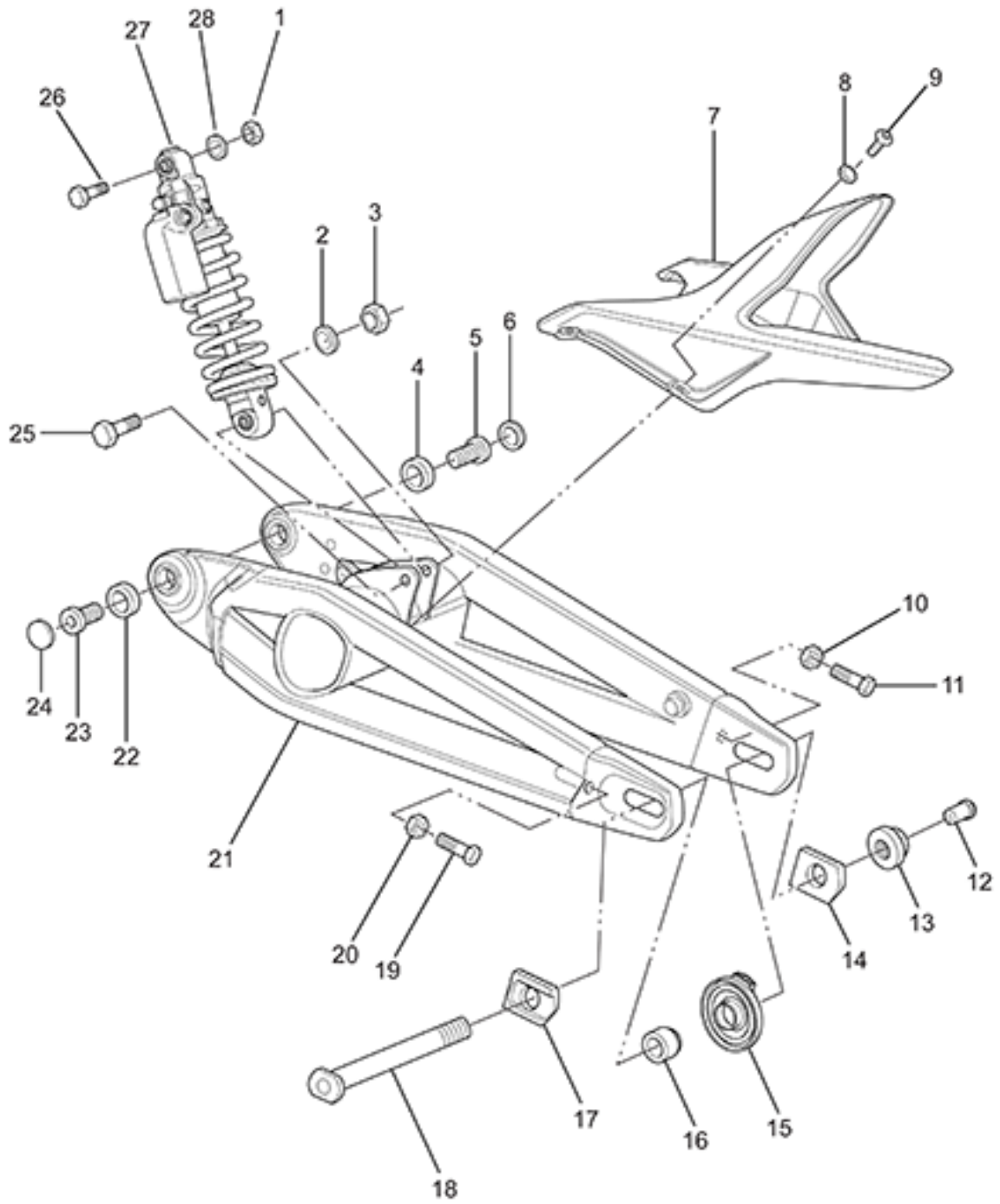

ZEV0036 - Rear Suspension

Callout	Part Number	Part Name	Qty. per Motorcycle
1	90-02050	PREVAILING TORQUE TYPE NUT DIN 985 M10-8 ZM-F-01 REV 02	1
2	90-02100	WASHER ISO 7089 10-200 HV ZM-F-01 REV 02	1
3	90-02050	PREVAILING TORQUE TYPE NUT DIN 985 M10-8 ZM-F-01 REV 02	1
4	20-06138	BEARING 6204 SWINGARM/WHEEL NOTE: Bearing used as swing arm bearing in some models and as the wheel bearing (qty of 5; 2 in front and three in rear wheel) in 2015 and later models. NOTE: Manufacturer part number is 6204-2RS	1
5	20-06130	STUB AXLE	1
6	20-06755	SWINGARM PIVOT BEARING SEAL PROTECTOR	1
7	24-08157	REAR INNER FENDER NOTE: Supersedes part number 24-04438	1
8	90-04085	WASHER M5 X 11 X 1 NYLON 6/6 BLACK	1
9	90-04084	HEXAGON SOCKET BUTTON HEAD CAP SCREW ISO 7380 M5X16-8.8 ZM-F-11 REV 03	1
10	90-05088	HEXAGON FLANGE NUT DIN 6923 M8-1.25 ZM-F-01 REV 03 NOTE: Axle adjusters jam nut	1
11	90-03030	HEXAGON HEAD SCREW DIN 933 M8X40-10.9 ZM-F-01 REV 03	1
12	20-05792	AXLE COVER NOTE: USED ONLY ON EU FX	1
13	90-05678	U-NUT M20X1.5 FN 27S 15H (REAR AXLE NUT) NOTE: Rear Axle Nut	1
14	26-08123	REAR AXLE ADJUSTER PUSH BLOCK NUT SIDE	1
15	45-07496	MPI WHEEL SPEED SENSOR	1
16	23-07489	WHEEL SPACER DRIVE SIDE REAR	1
17	26-08124	REAR AXLE ADJUSTER PUSH BLOCK HEAD SIDE	1
18	23-08032	REAR AXLE 20MM HOLLOW, ROUNDED END	1
19	90-03030	HEXAGON HEAD SCREW DIN 933 M8X40-10.9 ZM-F-01 REV 03	1
20	90-05088	HEXAGON FLANGE NUT DIN 6923 M8-1.25 ZM-F-01 REV 03 NOTE: Axle adjusters jam nut	1
21	26-08068	X SWINGARM EXTENDED REAR AXLE SLOT NOTE: Supersedes part number 21-07748.	1
22	20-06138	BEARING 6204 SWINGARM/WHEEL NOTE: Bearing used as swing arm bearing in some models and as the wheel bearing (qty of 5; 2 in front and three in rear wheel) in 2015 and later models. NOTE: Manufacturer part number is 6204-2RS	1

23	20-06130	STUB AXLE	1
24	20-06755	SWINGARM PIVOT BEARING SEAL PROTECTOR	1
25	90-05711	LOWER SHOCK EYE BOLT M10-1.5X60MM	1
26	90-05711	LOWER SHOCK EYE BOLT M10-1.5X60MM	1
27	22-05879	FX SHOCK 40MM	1
28	90-02100	WASHER ISO 7089 10-200 HV ZM-F-01 REV 02	1



ZEV0035 - Body Trim

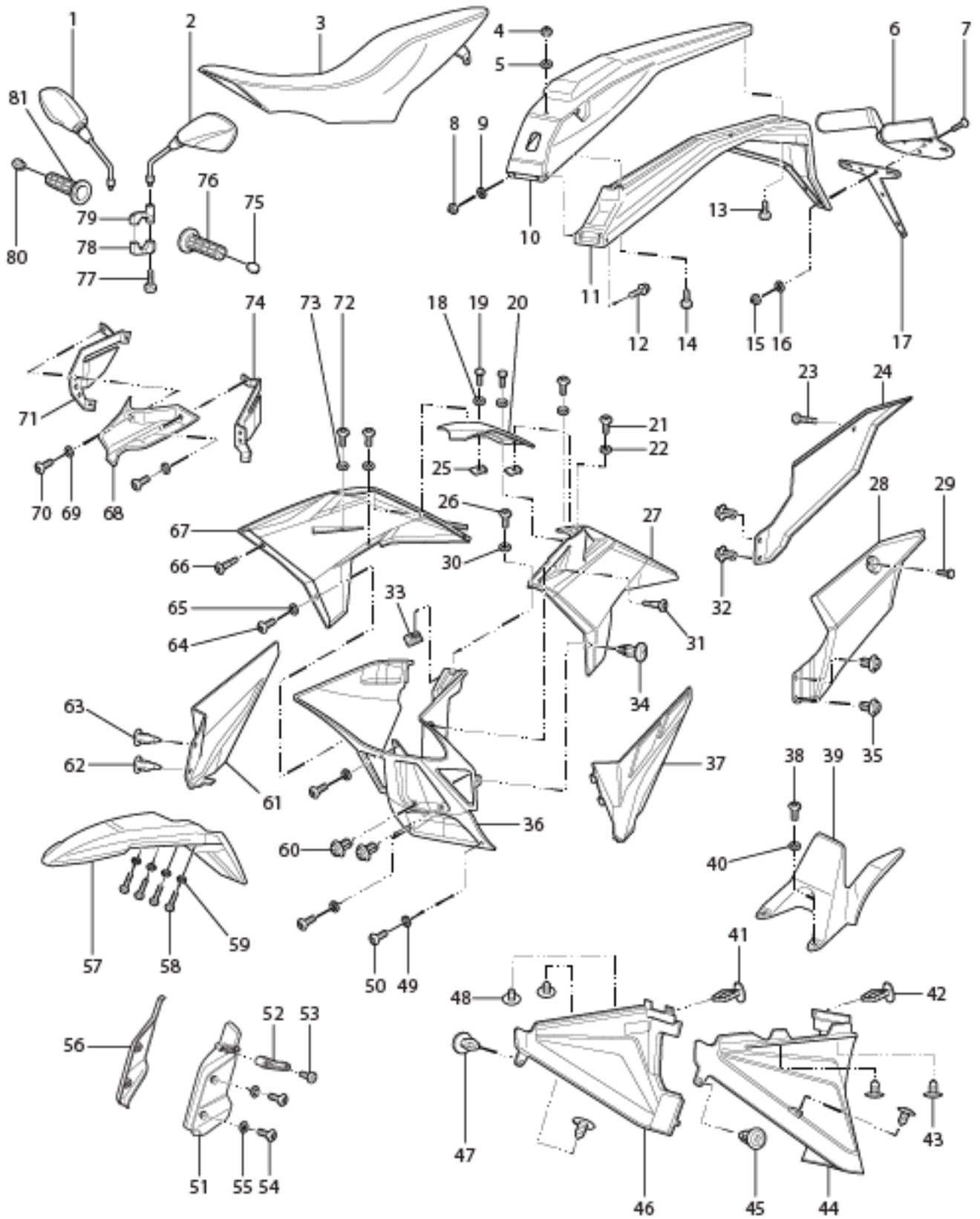

## ZEV0035 - Body Trim

Callout	Part Number	Part Name	Qty. per Motorcycle
1	27-08057	MIRROR RH	1
2	27-08056	MIRROR LH	1
3	24-06001	XXM SEAT	1
4	90-02053	PREVAILING TORQUE TYPE NUT DIN 985 M5-08 ZM-F-01 REV 02	1
5	90-02101	WASHER ISO 7089 5-200HV ZM-F-01 REV 02	1
6	24-05285	XXM REFLECTOR MOUNT BRACKET	1
7	90-05244	HEXAGON SOCKET COUNTERSUNK HEAD SCREW ISO 10642 M5X12-10.9 ZM-F-01 REV 03	1
8	90-02053	PREVAILING TORQUE TYPE NUT DIN 985 M5-08 ZM-F-01 REV 02	1
9	90-02101	WASHER ISO 7089 5-200HV ZM-F-01 REV 02	1
10	24-04449-1	XXM BODY TAIL PP BLACK#2	1
11	24-04451	X/MX TAIL POD	1
12	90-02610	HEXAGON FLANGE BOLT DIN 6921 OR ISO 4162 M5X20 ZM-F-01 REV 02	1
13	90-05887	PHILIPS HEAD SHEET METAL SCREW 10 X 1/2	1
14	90-02610	HEXAGON FLANGE BOLT DIN 6921 OR ISO 4162 M5X20 ZM-F-01 REV 02	1
15	90-02053	PREVAILING TORQUE TYPE NUT DIN 985 M5-08 ZM-F-01 REV 02	1
16	90-02101	WASHER ISO 7089 5-200HV ZM-F-01 REV 02	1
17	24-05160	LICENSE PLATE BRACKET NOTE: ONLY USED ON EU/ AUSTRALIA/ UK REGIONS	1
18	90-02101	WASHER ISO 7089 5-200HV ZM-F-01 REV 02	1
19	90-07285	HEXAGON FLANGE BOLT DIN 6921 OR ISO 4162 M5X16 ZM-F-01 REV 03 ZM-L-01 REV 01	1
20	24-07567	XXM TOP CENTER CONSOLE WITH MACHINE FEATURE TO CLEAR GUSSET	1
21	90-04084	HEXAGON SOCKET BUTTON HEAD CAP SCREW ISO 7380 M5X16-8.8 ZM-F-11 REV 03	1
22	90-04085	WASHER M5 X 11 X 1 NYLON 6/6 BLACK	1
23	90-07284	HEX FLANGE BOLT M8X25	1
24	24-03873	REAR NUMBER PLATE RIGHT SIDE WHITE	1
24	24-03873-1	REAR NUMBER PLATE RIGHT SIDE BLACK#2	1
25	90-02140	CLIP-ON U-NUT M5X15.8DP	1
26	90-04084	HEXAGON SOCKET BUTTON HEAD CAP SCREW ISO 7380 M5X16-8.8 ZM-F-11 REV 03	1
27	24-05059-1	FAIRING FRONT LEFT POLYPROPYLENE WHITE	1
27	24-05059-2	FAIRING FRONT LEFT POLYPROPYLENE BLACK 13MY IMP	1

28	24-03874	REAR NUMBER PLATE LEFT SIDE, WHITE	1
28	24-03874-1	REAR NUMBER PLATE LEFT SIDE BLACK#2	1
29	90-07284	HEX FLANGE BOLT M8X25	1
30	90-04085	WASHER M5 X 11 X 1 NYLON 6/6 BLACK	1
31	20-03066	RIVET PUSH PUSH NYLON M6	1
32	90-08055	RIVET/TREE FASTENER 5MM OD PUSH SCREW TYPE	1
33	90-02140	CLIP-ON U-NUT M5X15.8DP	1
34	90-08038	RIVET/TREE FASTENER M6 NYLON SCREW RIVET	1
35	90-08055	RIVET/TREE FASTENER 5MM OD PUSH SCREW TYPE	1
36	24-06043	XXM FAIRING CENTER	1
37	24-08259	LONGBRICK GAP FILLER LEFT ASSEMBLY	1
38	90-04084	HEXAGON SOCKET BUTTON HEAD CAP SCREW ISO 7380 M5X16-8.8 ZM-F-11 REV 03	1
39	24-08157	REAR INNER FENDER NOTE: Supersedes part number 24-04438	1
40	90-04085	WASHER M5 X 11 X 1 NYLON 6/6 BLACK	1
41	90-08038	RIVET/TREE FASTENER M6 NYLON SCREW RIVET	1
42	90-08038	RIVET/TREE FASTENER M6 NYLON SCREW RIVET	1
43	90-03114	XXM TREE CLIP 4MM X 8MM LG X 11MM HD	1
44	24-06190	XXM CONTROLLER COVER L 14MY IMPL	1
45	90-08038	RIVET/TREE FASTENER M6 NYLON SCREW RIVET	1
46	24-06191	XXM CONTROLLER COVER R 14MY IMPL	1
47	90-08038	RIVET/TREE FASTENER M6 NYLON SCREW RIVET	1
48	90-03114	XXM TREE CLIP 4MM X 8MM LG X 11MM HD	1
49	90-04085	WASHER M5 X 11 X 1 NYLON 6/6 BLACK	1
50	90-04084	HEXAGON SOCKET BUTTON HEAD CAP SCREW ISO 7380 M5X16-8.8 ZM-F-11 REV 03	1
51	24-08070	FORK GUARD LEFT	1
52	24-08071	FORK GUARD CLAMP	1
53	90-05886	PHILIPS HEAD SHEET METAL SCREW 8 X 1/2	1
54	90-04084	HEXAGON SOCKET BUTTON HEAD CAP SCREW ISO 7380 M5X16-8.8 ZM-F-11 REV 03	1
55	90-04085	WASHER M5 X 11 X 1 NYLON 6/6 BLACK	1
56	24-08069	FORK GUARD RIGHT	1
57	24-08191	FRONT FENDER DIRT BRAKE LINE HOLE	1
58	90-07285	HEXAGON FLANGE BOLT DIN 6921 OR ISO 4162 M5X16 ZM-F-01 REV 03 ZM-L-01 REV 01	1
59	90-02101	WASHER ISO 7089 5-200HV ZM-F-01 REV 02	1
60	90-08055	RIVET/TREE FASTENER 5MM OD PUSH SCREW TYPE	1
61	24-08260	LONGBRICK GAP FILLER RIGHT ASSEMBLY	1
62	20-03066	RIVET PUSH PUSH NYLON M6	1
63	20-03066	RIVET PUSH PUSH NYLON M6	1
64	90-04084	HEXAGON SOCKET BUTTON HEAD CAP SCREW ISO 7380 M5X16-8.8 ZM-F-11 REV 03	1
65	90-04085	WASHER M5 X 11 X 1 NYLON 6/6 BLACK	1



66	20-03066	RIVET PUSH PUSH NYLON M6	1
67	24-05058-1	FAIRING FRONT RIGHT POLYPROPYLENE WHITE	1
67	24-05058-2	FAIRING FRONT RIGHT POLYPROPYLENE BLACK 13MY IMP	1
68	24-07673	SHORT NOSE DUAL BEAM FLY-SCREEN	1
69	90-04085	WASHER M5 X 11 X 1 NYLON 6/6 BLACK	1
70	90-04084	HEXAGON SOCKET BUTTON HEAD CAP SCREW ISO 7380 M5X16-8.8 ZM-F-11 REV 03	1
71	20-06677	XMV HEADLIGHT MOUNT RIGHT SIDE	1
72	90-04084	HEXAGON SOCKET BUTTON HEAD CAP SCREW ISO 7380 M5X16-8.8 ZM-F-11 REV 03	1
73	90-04085	WASHER M5 X 11 X 1 NYLON 6/6 BLACK	1
74	20-06678	XMV HEADLIGHT MOUNT LEFT SIDE	1
75	27-08002	RIDER INTERFACE MISCELLANEOUS COMPONENT HANDLEBAR END CAP	1
76	27-08007	HAND GRIP LEFT SIDE	1
77	90-07265	HEXAGON SOCKET HEAD CAP SCREW ISO 4762 M6X20-8.8 ZM-F-01 REV 03 ZM-L-01 REV 01	1
78	24-02961	MIRROR MOUNT CLAMP	1
79	26-08060	MIRROR LH MOUNT LOW PROFILE NOTE: Bottom part of the mirror mount LH	1
80	27-08002	RIDER INTERFACE MISCELLANEOUS COMPONENT HANDLEBAR END CAP	1
81	27-08006	HAND GRIP THROTTLE SIDE	1

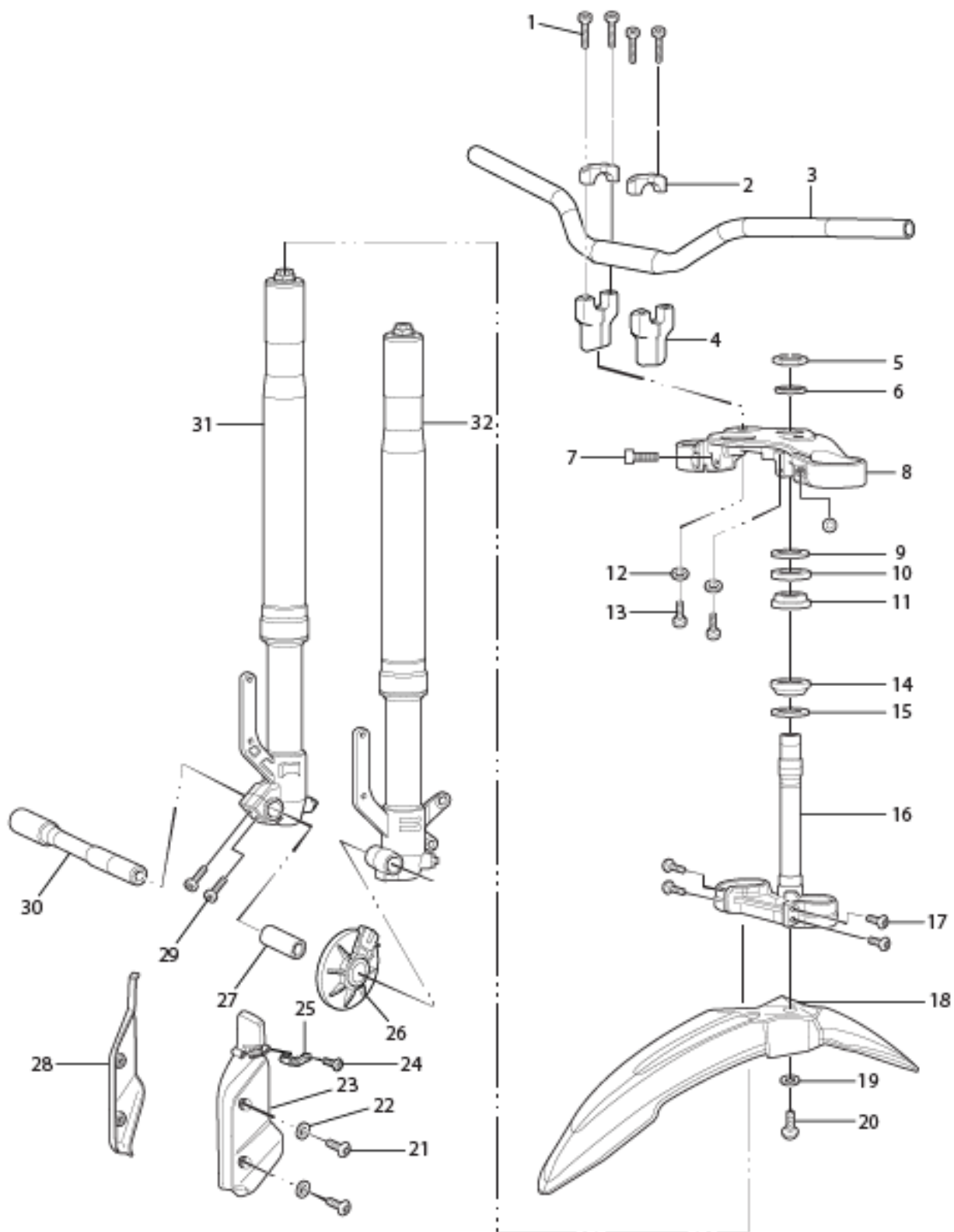

## ZEV0034 - Steering Systems

Callout	Part Number	Part Name	Qty. per Motorcycle
1	90-02094	HEXAGON SOCKET HEAD CAP SCREW ISO 4762 M8X25-10.9 ZM-F-01 REV 03	1
2	22-00687	S HANDLEBAR CLAMP	1
3	27-08050	HIGH RISE OFF-ROAD HANDLEBAR NOTE: Supersedes 27-08032.	1
4	22-00688	S HANDLEBAR RISER	1
5	22-06279	STEERING STEM THIN NUT M27 X 1.5 X 8MM	1
6	20-06278	WASHER 41 - 27.5 X 2 MM	1
7	90-02094	HEXAGON SOCKET HEAD CAP SCREW ISO 4762 M8X25-10.9 ZM-F-01 REV 03	1
8	22-07625	XXM UPPER TRIPLE CLAMP 15MY IMP	1
9	22-06257	STEERING STEM LOCK NUT M 30 X1.5 MM	1
10	81-08045	BEARING LIP SEAL OVERMOLDED 55MM OD NOTE: Supersedes part 20-06113	1
11	20-06068	STEERING HEAD BEARING KOYO SAC3055-1	1
12	90-02043	TOOTHED LOCK WASHER WITH EXTERNAL TEETH DIN 6797 A M10-B85 ZM-F-01 REV 02	1
13	90-07259	HEXAGON SOCKET THIN HEAD CAP SCREW DIN 7984 M10X35-8.8	1
14	20-06068	STEERING HEAD BEARING KOYO SAC3055-1	1
15	81-08045	BEARING LIP SEAL OVERMOLDED 55MM OD NOTE: Supersedes part 20-06113	1
16	22-07627	XXM LOWER TRIPLE CLAMP ASSY 15MY IMP	1
17	90-02094	HEXAGON SOCKET HEAD CAP SCREW ISO 4762 M8X25-10.9 ZM-F-01 REV 03	1
18	24-08191	FRONT FENDER DIRT BRAKE LINE HOLE	1
19	90-02107	WASHER ISO 7093-1 5-200HV ZM-F-01 REV 02 NOTE: Does not apply to S and SR	1
20	90-07285	HEXAGON FLANGE BOLT DIN 6921 OR ISO 4162 M5X16 ZM-F-01 REV 03 ZM-L-01 REV 01	1
21	90-04084	HEXAGON SOCKET BUTTON HEAD CAP SCREW ISO 7380 M5X16-8.8 ZM-F-11 REV 03	1
22	90-04085	WASHER M5 X 11 X 1 NYLON 6/6 BLACK	1
23	24-08070	FORK GUARD LEFT	1
24	90-05887	PHILIPS HEAD SHEET METAL SCREW 10 X 1/2	1
25	24-08071	FORK GUARD CLAMP	1
26	45-07496	MPI WHEEL SPEED SENSOR	1
27	23-07775	FRONT WHEEL BEARING TUBE	1
28	24-08069	FORK GUARD RIGHT	1
29	90-07269	HEXAGON SOCKET HEAD CAP SCREW ISO 4762 M8X30-10.9 ZM-F-01 REV 03 ZM-L-01 REV 01	1

30	23-07491	HOLLOW AXLE FRONT	1
31	22-05869	FX FORK 41MM RIGHT	1
32	22-05868	FX FORK 41MM LEFT	1



ZEV0033 - Wheel Assy

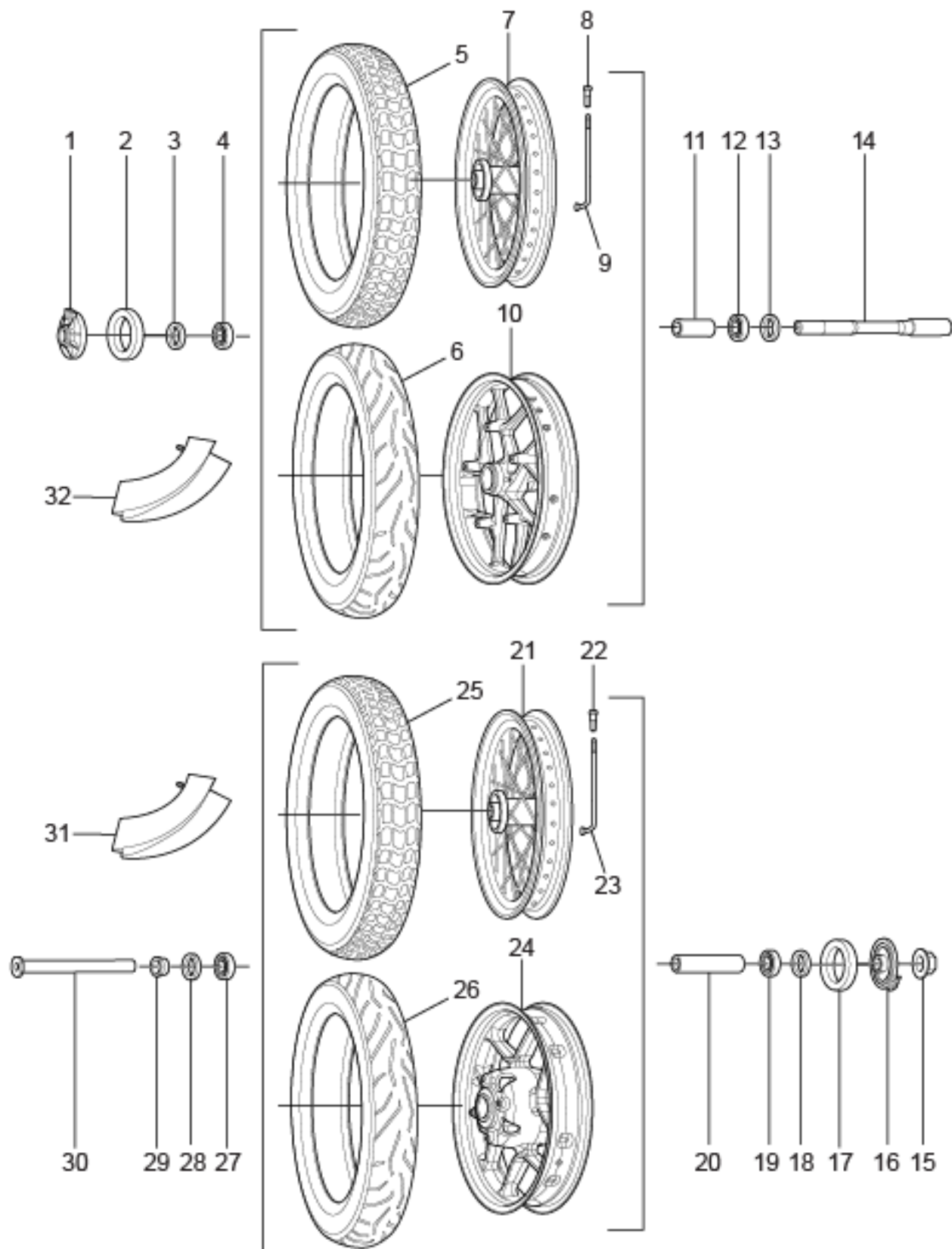

## ZEV0033 - Wheel Assy

Callout	Part Number	Part Name	Qty. per Motorcycle
1	45-07496	MPI WHEEL SPEED SENSOR	1
2	25-08080	ABS MAGNET RING	1
3	23-07774	6204 BEARING DUST SEAL	1
4	20-06138	BEARING 6204 SWINGARM/WHEEL NOTE: Bearing used as swing arm bearing in some models and as the wheel bearing (qty of 5; 2 in front and three in rear wheel) in 2015 and later models. NOTE: Manufacturer part number is 6204-2RS	1
5	23-05054	PIRELLI MT90/AT, 90/90-21 M/C 54S	1
6	<i>Not Applicable to this Bike Model</i>		
7	23-08067	WHEEL 1.85 X 21 XMX FRONT LACED WHEEL ASSY 1065 SPOKE NOTE: Zero FX front wheel does not include ABS Ring p/n 25-08080, which may need to be ordered separately if you are unable to press out the existing ring.	1
8	23-06131	SPOKE NIPPLE 3.2MM NOTE: Fits FX/DS NOTE: For front wheel	1
9	23-08049	SPOKE FRONT INSIDE 1065 3.2 228	1
9	23-08050	SPOKE FRONT OUTSIDE 1065 3.2 224	1
10	<i>Not Applicable to this Bike Model</i>		
11	23-07775	FRONT WHEEL BEARING TUBE	1
12	20-06138	BEARING 6204 SWINGARM/WHEEL NOTE: Bearing used as swing arm bearing in some models and as the wheel bearing (qty of 5; 2 in front and three in rear wheel) in 2015 and later models. NOTE: Manufacturer part number is 6204-2RS	1
13	23-07774	6204 BEARING DUST SEAL	1
14	23-07491	HOLLOW AXLE FRONT	1
15	90-05678	U-NUT M20X1.5 FN 27S 15H (REAR AXLE NUT) NOTE: Rear Axle Nut	1
16	45-07496	MPI WHEEL SPEED SENSOR	1
17	25-08080	ABS MAGNET RING	1
18	23-07774	6204 BEARING DUST SEAL	1
19	20-06138	BEARING 6204 SWINGARM/WHEEL NOTE: Bearing used as swing arm bearing in some models and as the wheel bearing (qty of 5; 2 in front and three in rear wheel) in 2015 and later models. NOTE: Manufacturer part number is 6204-2RS	1
20	23-07776	REAR WHEEL BEARING TUBE 15MY	1

21	23-08038	2.50 X 18 XMX REAR LACED WHEEL ASSY NEW LOGO RIM LOCK NOTE: Rim lock front wheel used on the 2015, 2016 and 2017 Zero MMX.	1
21	23-08048	WHEEL 2.50 X 18 XMX REAR LACED WHEEL ASSY 1065 SPOKE NOTE: Does not come w/ ABS ring p/n: 25-08080	1
22	23-03942	SPOKE NIPPLE NOTE: for rear wheel	1
23	23-08051	SPOKE REAR INSIDE 1065 18" 3.5 X 192	1
23	23-08052	SPOKE REAR OUTSIDE 1065 18" 3.5 X 19	1
24	<i>Not Applicable to this Bike Model</i>		
25	23-05055	PIRELLI MT90/AT, 120/80-18 M/C 62S	1
26	<i>Not Applicable to this Bike Model</i>		
27	20-06138	BEARING 6204 SWINGARM/WHEEL NOTE: Bearing used as swing arm bearing in some models and as the wheel bearing (qty of 5; 2 in front and three in rear wheel) in 2015 and later models. NOTE: Manufacturer part number is 6204-2RS	1
28	23-07774	6204 BEARING DUST SEAL	1
29	23-07489	WHEEL SPACER DRIVE SIDE REAR	1
30	23-08032	REAR AXLE 20MM HOLLOW, ROUNDED END	1
31	23-05687	FX REAR TUBE 13MY IMPL	1
32	23-05686	FX FRONT TUBE 13MY IMPL	1





ZEV0032 - Braking

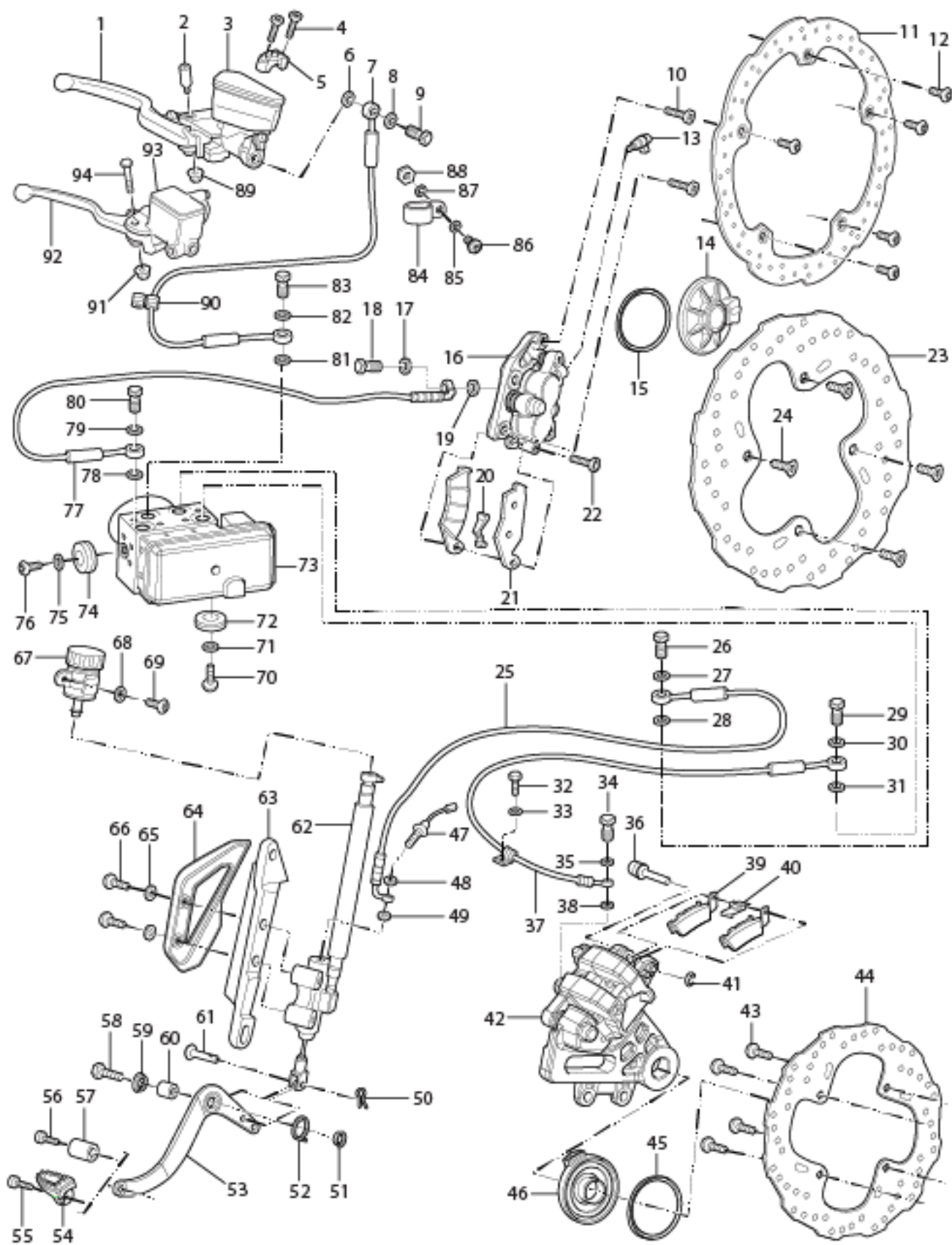

## ZEV0032 - Braking

Callout	Part Number	Part Name	Qty. per Motorcycle
1	25-08031	FX/MX BRAKE LEVER JJUAN	1
2	PA-126	BRAKE LEVER PIVOT BOLT	1
3	25-07681	JJUAN 12MM FRONT MASTER CYLINDER XMX	1
4	90-07265	HEXAGON SOCKET HEAD CAP SCREW ISO 4762 M6X20-8.8 ZM-F-01 REV 03 ZM-L-01 REV 01	1
5	24-08064	MASTER CYLINDER CLAMP	1
6	PA-128	BANJO GASKET	1
7	25-08095	FX FRONT BRAKE LINE MC TO HCU	1
8	PA-128	BANJO GASKET	1
9	PA-129	BANJO BOLT MC	1
10	90-08013	HEX HEAD SCREW M8-1.25 X 35MM	1
11	<i>Not Applicable to this Bike Model</i>		
12	<i>Not Applicable to this Bike Model</i>		
13	PA-133	BLEEDER VALVE	1
14	45-07496	MPI WHEEL SPEED SENSOR	1
15	25-08080	ABS MAGNET RING	1
16	25-07687	JJUAN 27MM X2 FRONT CALIPER XMX	1
17	PA-128	BANJO GASKET	1
18	PA-132	BANJO BOLT FRONT CALIPER	1
19	PA-128	BANJO GASKET	1
20	PA-135	FRONT BRAKE PAD ANTI RATTLE CLIP	1
21	25-08027	BRAKE PADS SET FRONT XMX	1
22	90-08013	HEX HEAD SCREW M8-1.25 X 35MM	1
23	25-08063	BRAKE ROTOR 240MM XMX FRONT	1
24	90-08015	HEX SOCKET BUTTON HEAD SCREW M8X20 NOTE: Superseded by 90-07516.	1
25	25-07822	FX REAR BRAKE LINE MC TO HCU	1
26	PA-131	BANJO BOLT AND HCU	1
27	PA-128	BANJO GASKET	1
28	PA-128	BANJO GASKET	1
29	PA-131	BANJO BOLT AND HCU	1
30	PA-128	BANJO GASKET	1
31	PA-128	BANJO GASKET	1
32	90-04084	HEXAGON SOCKET BUTTON HEAD CAP SCREW ISO 7380 M5X16-8.8 ZM-F-11 REV 03	1
33	90-04085	WASHER M5 X 11 X 1 NYLON 6/6 BLACK	1
34	PA-136	BANJO BOLT REAR CALIPER	1
35	PA-128	BANJO GASKET	1
36	PA-137	REAR CALIPER SLIDE BOLT	1
37	25-08094	XMX REAR BRAKE LINE HCU TO CALIPER NOTE: Supersedes part number 25-07823.	1

38	PA-128	BANJO GASKET	1
39	25-08028	BRAKE PADS SET REAR XMX	1
40	PA-139	REAR BRAKE PAD ANTI RATTLE CLIP	1
41	PA-140	REAR CALIPER SLIDE BOLT CLIP	1
42	25-08100	JJUAN 30MM REAR CALIPER	1
43	90-08015	HEX SOCKET BUTTON HEAD SCREW M8X20 NOTE: Superseded by 90-07516.	1
44	25-08057	BRAKE ROTOR 240MM SDS/XMX COMMON	1
45	25-08080	ABS MAGNET RING	1
46	45-07496	MPI WHEEL SPEED SENSOR	1
47	PA-144	REAR BRAKE LIGHT SWITCH NOTE: Not sold separately. Please order the Master Cylinder.	1
48	PA-128	BANJO GASKET	1
49	PA-128	BANJO GASKET	1
50	PA-27	COTTER PIN	1
51	20-02465	IGLIDE BEARING GFM-1416-06	1
52	20-05184	SPRING TORSION X BRAKE PEDAL	1
53	25-08071	BRAKE PEDAL BASE	1
54	25-08072	BRAKE PEDAL OFF ROAD PEG	1
55	90-07265	HEXAGON SOCKET HEAD CAP SCREW ISO 4762 M6X20-8.8 ZM-F-01 REV 03 ZM-L-01 REV 01	1
56	90-07265	HEXAGON SOCKET HEAD CAP SCREW ISO 4762 M6X20-8.8 ZM-F-01 REV 03 ZM-L-01 REV 01	1
57	25-08072	BRAKE PEDAL OFF ROAD PEG	1
58	90-07003	REAR BRAKE PEDAL PIVOT BOLT	1
59	20-02465	IGLIDE BEARING GFM-1416-06	1
60	20-02455	X BRAKE PEDAL SPACER	1
61	90-02133	1/4 X 3/4 CLEVIS PIN STEEL ZINC	1
62	25-06731	JJUAN 11MM REAR MASTER CYLINDER XMX	1
63	20-06295	REAR MASTER CYLINDER BRACKET XMX M6 THRU	1
64	25-07457	MASTER CYLINDER GUARD FOR J-JUAN MASTER CYLINDER	1
65	90-02103	WASHER ISO 7089 6-200HV ZM-F-01 REV 02	1
66	90-07323	HEXAGON SOCKET BUTTON HEAD CAP SCREW ISO 7380 M6X25-8.8 ZM-F-01 REV 03 ZM-L-01 REV 01	1
67	25-06731	JJUAN 11MM REAR MASTER CYLINDER XMX	1
68	90-02103	WASHER ISO 7089 6-200HV ZM-F-01 REV 02	1
69	90-07273	HEXAGON SOCKET BUTTON HEAD CAP SCREW ISO 7380 M6X16-8.8 ZM-F-01 REV 03 ZM-L-01 REV 01	1
70	90-07273	HEXAGON SOCKET BUTTON HEAD CAP SCREW ISO 7380 M6X16-8.8 ZM-F-01 REV 03 ZM-L-01 REV 01	1
71	90-02105	WASHER ISO 7093-1 6-200 HV ZM-F-01 REV 02	1
72	90-08027	GROMMET VIBRATION ISOLATION M6	1
73	25-08092	BOSCH ABS HCU FLUID FILLED 6 PROFILE VARIANTS NOTE: Supersedes part number 25-08081 and 25-08082.	1

74	90-08027	GROMMET VIBRATION ISOLATION M6	1
75	90-02105	WASHER ISO 7093-1 6-200 HV ZM-F-01 REV 02	1
76	90-07273	HEXAGON SOCKET BUTTON HEAD CAP SCREW ISO 7380 M6X16-8.8 ZM-F-01 REV 03 ZM-L-01 REV 01	1
77	25-08094	XMX REAR BRAKE LINE HCU TO CALIPER NOTE: Supersedes part number 25-07823.	1
78	PA-128	BANJO GASKET	1
79	PA-128	BANJO GASKET	1
80	PA-131	BANJO BOLT AND HCU	1
81	PA-128	BANJO GASKET	1
82	PA-128	BANJO GASKET	1
83	PA-131	BANJO BOLT AND HCU	1
84	90-08030	BRAKES MISCELLANEOUS COMPONENT LOOP CUSHINED P-CLAMP M10-1/4"	1
85	90-02101	WASHER ISO 7089 5-200HV ZM-F-01 REV 02	1
86	90-04084	HEXAGON SOCKET BUTTON HEAD CAP SCREW ISO 7380 M5X16-8.8 ZM-F-11 REV 03	1
87	90-02101	WASHER ISO 7089 5-200HV ZM-F-01 REV 02	1
88	90-02053	PREVAILING TORQUE TYPE NUT DIN 985 M5-08 ZM-F-01 REV 02	1
89	PA-130	BRAKE LEVER PIVOT BOLT NUT	1
90	25-08023	BRAKE LINE/WHEEL SPEED SENSOR WIRE DOUBLE C CLIP	1
91	PA-130	BRAKE LEVER PIVOT BOLT NUT	1
92	PA-230	MASTER CYLINDER LEVER	1
93	25-07681	JJUAN 12MM FRONT MASTER CYLINDER XMX	1
94	PA-231	MASTER CYLINDER LEVER PIVOT BOLT	1

ZEV0031 - Lighting

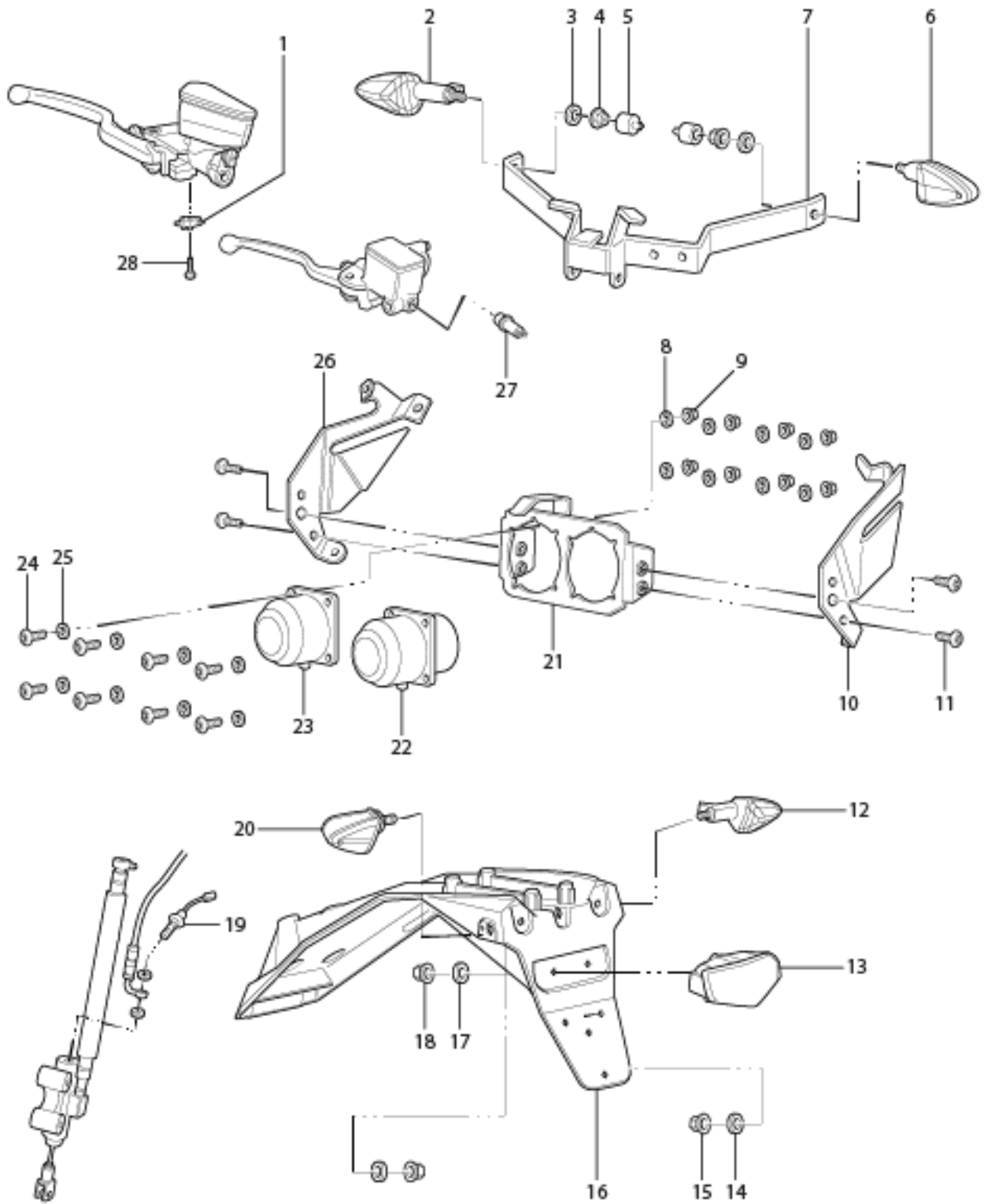

## ZEV0031 - Lighting

Callout	Part Number	Part Name	Qty. per Motorcycle
1		<i>Not Applicable to this Bike Model</i>	
2	65-03462	TURN SIGNAL FR-RH RR-LH	1
3	90-02043	TOOTHED LOCK WASHER WITH EXTERNAL TEETH DIN 6797 A M10-B85 ZM-F-01 REV 02	2
4	90-02072	HEXAGON THIN NUT ISO 4035 M10-04 ZM-F-01 REV 02	2
5	20-03146	TURN SIGNAL HEX NUT CAP	1
6	65-03463	TURN SIGNAL FR-LH RR-RH	1
7	26-08040	DASH SUPPORT BRACKET STEEL	1
8	90-02102	WASHER UNIVERSAL (SIZE 1)	1
9	90-02052	PREVAILING TORQUE TYPE NUT DIN 985 M4-08 ZM-F-01 REV 03	1
10	20-06678	XXM HEADLIGHT MOUNT LEFT SIDE	1
11	90-02414	HEXAGON SOCKET BUTTON HEAD SCREW ISO 7380 M8X12-8.8 ZM-F-01 REV 03	4
12	65-03463	TURN SIGNAL FR-LH RR-RH	1
13	65-00600	TAIL LIGHT	1
14	90-02043	TOOTHED LOCK WASHER WITH EXTERNAL TEETH DIN 6797 A M10-B85 ZM-F-01 REV 02	2
15	90-02072	HEXAGON THIN NUT ISO 4035 M10-04 ZM-F-01 REV 02	2
16	24-04451	X/MX TAIL POD	1
17	90-02103	WASHER ISO 7089 6-200HV ZM-F-01 REV 02	10
18	90-02071	HEXAGON NUT ISO 4032 M6-8 ZM-F-01 REV 02	1
19	PA-144	REAR BRAKE LIGHT SWITCH NOTE: Not sold separately. Please order the Master Cylinder.	1
20	65-03462	TURN SIGNAL FR-RH RR-LH	1
21	20-06042	HEADLIGHT PIVOT BRACKET	1
22	65-06400	14MY XXM HEADLIGHT HIGH BEAM	1
23	65-06401	14MY XXM HEADLIGHT LOW BEAM	1
24	90-07123	HEXAGON SOCKET HEAD CAP SCREW ISO 4762 M4X16-8.8 ZM-F-01 REV 03 ZM-L-02 REV 01	1
25	90-02102	WASHER UNIVERSAL (SIZE 1)	1
26	20-06677	XXM HEADLIGHT MOUNT RIGHT SIDE	1
27	PA-228	STOP LAMP SWITCH	1
28	PA-61	BRAKE SWITCH SCREW	1

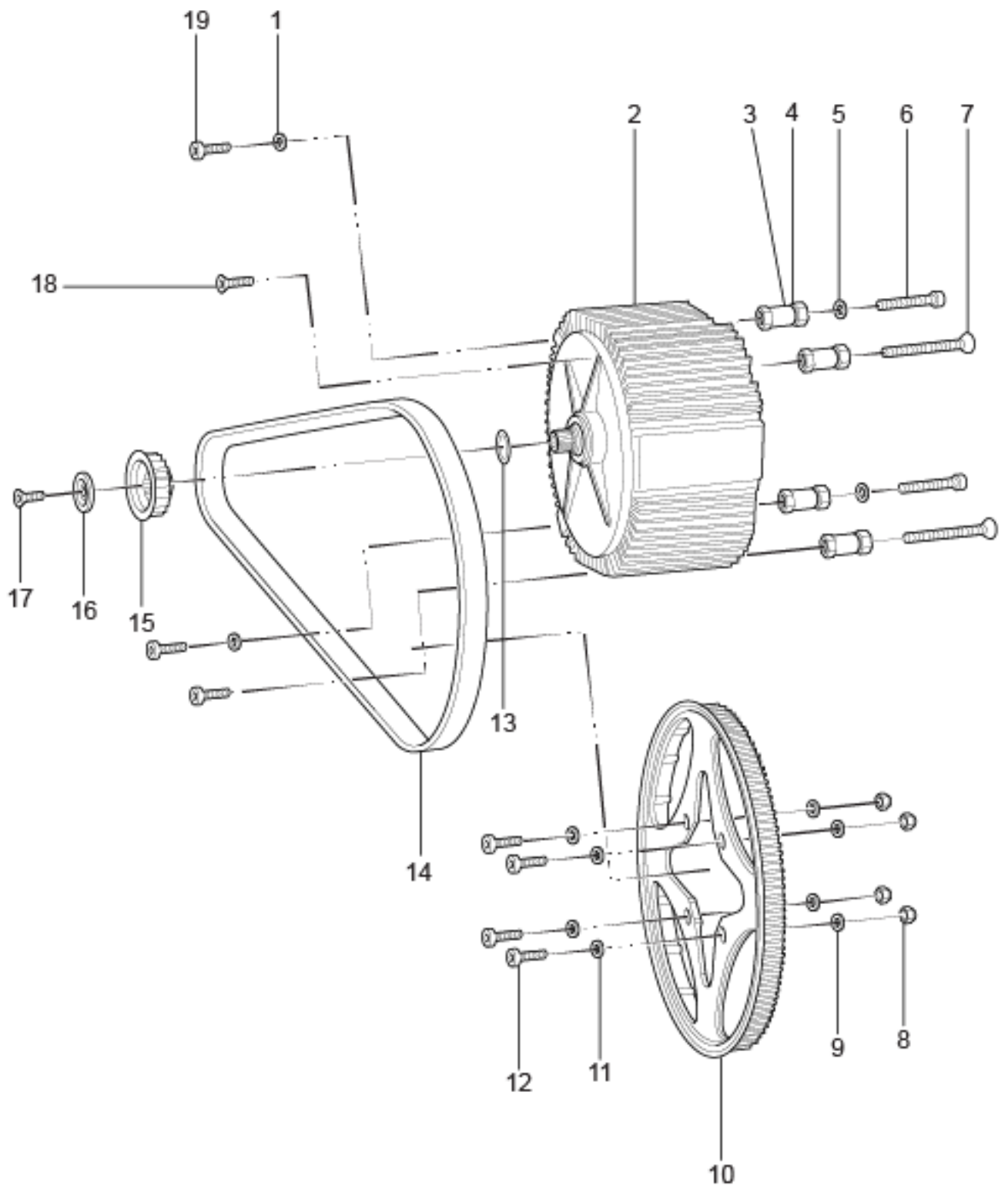



ZEV0039 - Motor and Drive System

Callout	Part Number	Part Name	Qty. per Motorcycle
1	90-02104	WASHER ISO 7089 -8-200 HV ZM-F-01 REV 02	1
2	30-08098	ZF75-5 IPM MOTOR SPLINED SHAFT	1
3	20-04773	MOTOR JACK SCREW OUTER	1
4	20-04774	MOTOR JACK SCREW INNER	1
5	90-02104	WASHER ISO 7089 -8-200 HV ZM-F-01 REV 02	1
6	90-05445	HEXAGON SOCKET HEAD CAP SCREW ISO 4762 M8X80-8.8 ZM-F-01 REV 03	1
7	90-05441	HEXAGON SOCKET COUNTERSUNK HEAD SCREW ISO 10642 M8X80-8.8 ZM-F-01 REV 03	1
8	90-03236	PREVAILING TORQUE TYPE NUT DIN 985 M8-10 ZM-F-01 REV 02	1
9	90-02104	WASHER ISO 7089 -8-200 HV ZM-F-01 REV 02	1
10	30-05090	65T 520 SPROCKET 132 MM BOLT CIR	1
10	30-08109	WHEEL SPROCKET 90T 11MM PITCH 17MM WIDE BELT COATED	1
11	90-02104	WASHER ISO 7089 -8-200 HV ZM-F-01 REV 02	1
12	90-08053	M8X30 HEXOBULAR SOCKET PAN HEAD ISO 14583 CLASS 10.9 ZM-F-01 REV 04 ZM-L-02 REV 01	1
13	30-05502	MOTOR SHAFT SPACER 1.5 MM FOR 1" SHAFT	1
14	30-08086	BELT 158T 11MM PITCH 17MM WIDE	1
15	30-08116	MOTOR SPROCKET 20T 11MM PITCH 17MM WIDE BELT ASSEMBLED	1
16	20-05453	LOW PROFILE BELT SPROCKET MOTOR SHAFT TOPHAT	1
17	90-02056	HEXAGON SOCKET COUNTERSUNK HEAD SCREW M10X25-8.8 MOTOR SHAFT NOTE: Bolt used to hold front sprocket in place onto the motor shaft. NOTE: Sprocket	1
18	90-08037	HEXALOBULAR (6 LOBE) SOCKET FLAT HEAD COUNTERSUNK SCREW ISO 14582 M8X30-10.9 ZM-F-01 REV 04	1
19	90-02096	MOTOR MOUNTING LEFT FRONT TOP AND LEFT FRONT BOTTOM BOLT	1

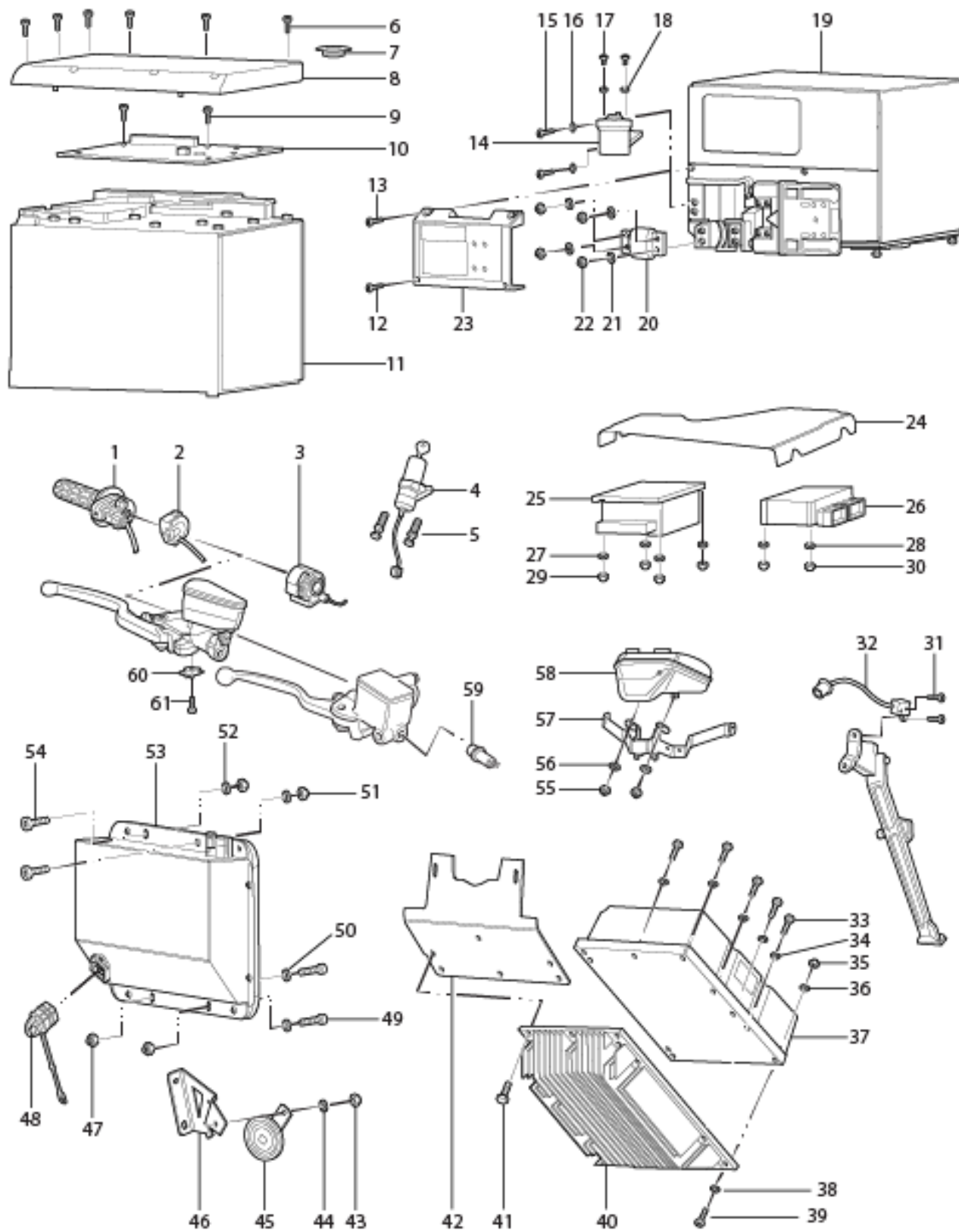

Callout	Part Number	Part Name	Qty. per Motorcycle
1	45-08039	THROTTLE BITRON HALL EFFECT PCB NOTE: Supersedes 27-08000	1
2	40-06054	KILL MODE START SWITCH	1
3	60-07780	LEFT HAND SWITCHGEAR ECIE	1
4	45-02692	KEYSWITCH LOCK ZADI, IGNITION SWITCH NOTE: This part is the ignition switch and keys only. If you want a matching helmet lock for 16MY motorcycles and older, please order p/n 20-05202. If you want the key switch and a lock for a tank trunk, please order 27-08030. If you want a ignition and matching locks for tank trunk and storage trunks, please order part number 27-08044.	1
5	90-02937	M8X14MM BREAK AWAY HEX BOLT NOTE: One Time Use Bolt	1
6	90-07126	HEXAGON SOCKET HEAD CAP SCREW ISO 4762 M4X8-8.8 ZM-F-01 REV 03 ZM-L-02 REV 01	1
7	20-04094	PLUG DIAG PORT 24.50 THRU 26.00 MM 12MY IMPL	1
8	40-08031	BMS PCB ASSY POTTED 17MY IMPL NOTE: PLEASE INCLUDE VIN# OF BIKE AND BATTERY SERIAL # FOR PROGRAMMING PURPOSES NOTE: FOR FX/FXP, IF BATTERY SERIAL NUMBER STARTS WITH 14SG**** PLEASE ORDER 41-06419 NOTE: Super seeded pn:40-07232	1
9	90-07126	HEXAGON SOCKET HEAD CAP SCREW ISO 4762 M4X8-8.8 ZM-F-01 REV 03 ZM-L-02 REV 01	1
10	40-08031	BMS PCB ASSY POTTED 17MY IMPL NOTE: PLEASE INCLUDE VIN# OF BIKE AND BATTERY SERIAL # FOR PROGRAMMING PURPOSES NOTE: FOR FX/FXP, IF BATTERY SERIAL NUMBER STARTS WITH 14SG**** PLEASE ORDER 41-06419 NOTE: Super seeded pn:40-07232	1
11	46-08117	ZF3.6 POWER PACK MODULE NOTE: VIN# and/or Warranty Claim Number Must Be Provided At Time Of Order	1
12	90-07128	HEXAGON SOCKET HEAD CAP SCREW ISO 4762 M4X35-8.8 ZM-F-01 REV 03 ZM-L-02 REV 01	1
13	90-07126	HEXAGON SOCKET HEAD CAP SCREW ISO 4762 M4X8-8.8 ZM-F-01 REV 03 ZM-L-02 REV 01	1
14	45-08099	ELECTRICAL COMPONENT EVC135 CONTACTOR NOTE: Modular contactor	1
15	90-07123	HEXAGON SOCKET HEAD CAP SCREW ISO 4762 M4X16-8.8 ZM-F-01 REV 03 ZM-L-02 REV 01	1

16	90-02102	WASHER UNIVERSAL (SIZE 1)	1
17	90-07125	HEXAGON SOCKET BUTTON HEAD SCREW ISO 7380 M5X10	1
18	90-02102	WASHER UNIVERSAL (SIZE 1)	1
19	46-08117	ZF3.6 POWER PACK MODULE NOTE: VIN# and/or Warranty Claim Number Must Be Provided At Time Of Order	1
20	45-06195	FUSE 300A 170VDC 4 HOLD MODIFIED CLASS T	1
21	90-02102	WASHER UNIVERSAL (SIZE 1)	1
22	90-02052	PREVAILING TORQUE TYPE NUT DIN 985 M4-08 ZM-F-01 REV 03	1
23	46-08059	MODULE FUSE COVER 17MY IMPL	1
24	24-05783	XXM CONTROLLER FORMEX TOP	1
25	60-07190	DC-DC CONV 500W SEVCON 622-11211 ABS UNITS	1
26	40-08145	ASSY MBB POTTED GEN2 STEP E NOTE: Please provide VIN, Case or Claim Number when ordering to ensure proper programming. NOTE: Supersedes 40-08071.	1
27	90-02102	WASHER UNIVERSAL (SIZE 1)	1
28	90-02102	WASHER UNIVERSAL (SIZE 1)	1
29	90-02052	PREVAILING TORQUE TYPE NUT DIN 985 M4-08 ZM-F-01 REV 03	1
29	90-02052	PREVAILING TORQUE TYPE NUT DIN 985 M4-08 ZM-F-01 REV 03	1
30	<i>Not Applicable to this Bike Model</i>		
31	90-07278	HEX SOCKET THIN HEAD CAP SCREW DIN 7984 M4X10	1
32	45-02413	HALL SENSOR SIDESTAND SWITCH	1
33	90-02052	PREVAILING TORQUE TYPE NUT DIN 985 M4-08 ZM-F-01 REV 03	1
34	90-02104	WASHER ISO 7089 -8-200 HV ZM-F-01 REV 02	1
35	90-02054	PREVAILING TORQUE TYPE NUT DIN 985 M6-8 ZM-F-01 REV 02	1
36	90-02103	WASHER ISO 7089 6-200HV ZM-F-01 REV 02	1
37	60-07009	CONTROLLER, SIZE 4 GEN 4.5 SEVCON	1
38	90-02103	WASHER ISO 7089 6-200HV ZM-F-01 REV 02	1
39	90-03251	HEXAGON SOCKET HEAD CAP SCREW ISO 4762 M6X30-8.8 ZM-F-01 REV 03	1
40	20-06553	XXM HEATSINK MY14	1
41	90-07269	HEXAGON SOCKET HEAD CAP SCREW ISO 4762 M8X30-10.9 ZM-F-01 REV 03 ZM-L-01 REV 01	1
42	20-05036	HEAT SINK MOUNT	1
43	90-02054	PREVAILING TORQUE TYPE NUT DIN 985 M6-8 ZM-F-01 REV 02	1
44	90-02103	WASHER ISO 7089 6-200HV ZM-F-01 REV 02	1
45	45-06774	DISC HORN K70/H12 V WITH BLACK ZINC	1
46	26-08041	CHASSIS STRUCTURE MOUNTING BRACKET HORN	1

47	90-02071	HEXAGON NUT ISO 4032 M6-8 ZM-F-01 REV 02	1
48	45-04864	CAVITY PLUG C13	1
49	90-07265	HEXAGON SOCKET HEAD CAP SCREW ISO 4762 M6X20-8.8 ZM-F-01 REV 03 ZM-L-01 REV 01	1
50	90-02103	WASHER ISO 7089 6-200HV ZM-F-01 REV 02	1
51	90-02071	HEXAGON NUT ISO 4032 M6-8 ZM-F-01 REV 02	1
52	90-02103	WASHER ISO 7089 6-200HV ZM-F-01 REV 02	1
53	40-08089	CALEX CHARGER ASSEMBLY 720W REG 10.5 EMC COMPLIANT NOTE: Supersedes part number 40-07488.	1
54	90-07265	HEXAGON SOCKET HEAD CAP SCREW ISO 4762 M6X20-8.8 ZM-F-01 REV 03 ZM-L-01 REV 01	1
55	90-02054	PREVAILING TORQUE TYPE NUT DIN 985 M6-8 ZM-F-01 REV 02	1
56	26-08040	DASH SUPPORT BRACKET STEEL	1
56	90-02103	WASHER ISO 7089 6-200HV ZM-F-01 REV 02	1
57	<i>Not Applicable to this Bike Model</i>		
58	40-08030	DASH LCD (ABS) BUG LOGO NOTE: Applicable 14MY-18MY	1
59	PA-228	STOP LAMP SWITCH	1

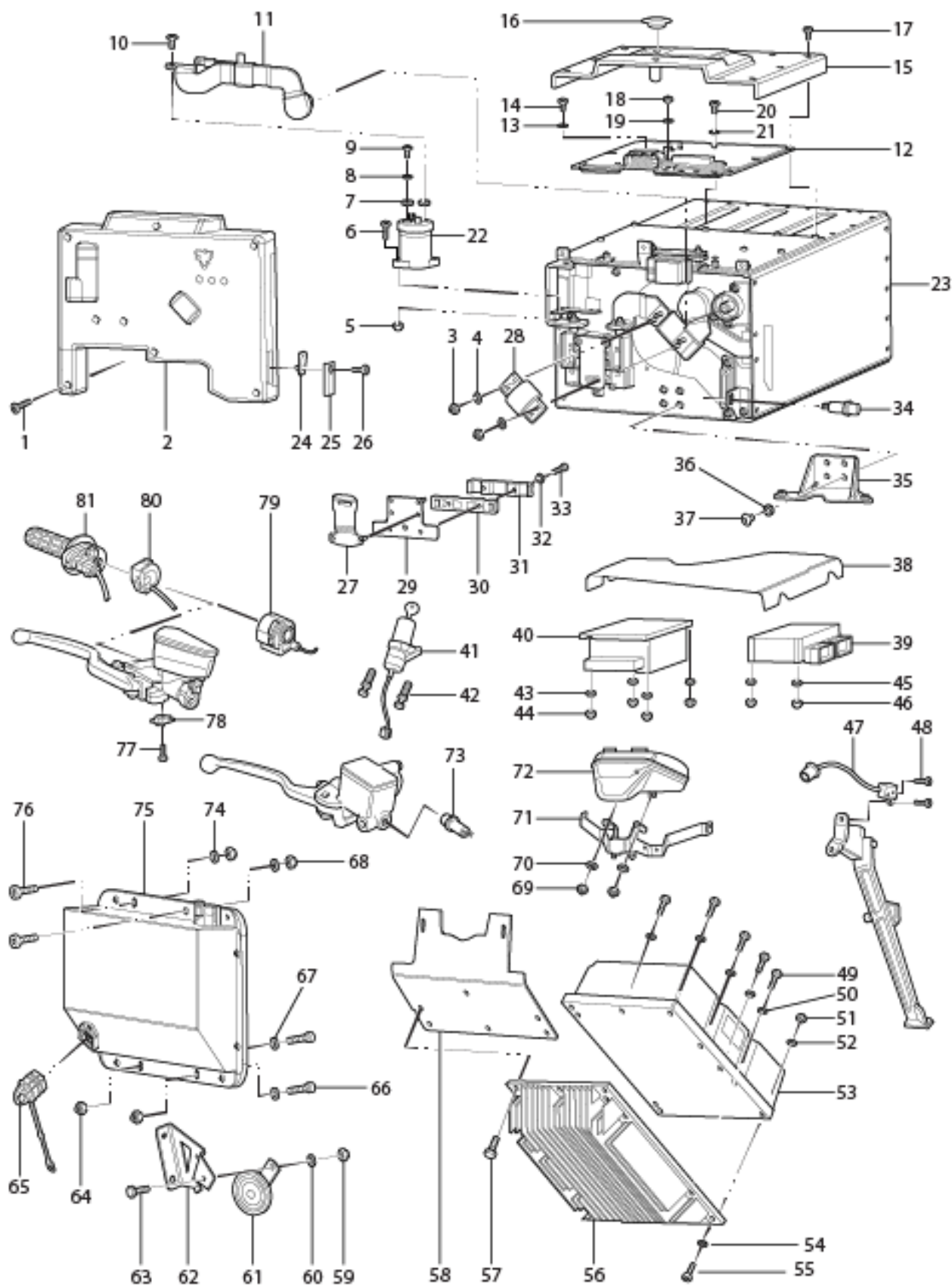

Callout	Part Number	Part Name	Qty. per Motorcycle
1	90-08047	HEXAGON SOCKET HEAD CAP SCREW ISO 4762 M4X30-8.8 ZM-F-01 REV 03 ZM-L-02 REV 01	1
2	46-08065	LONGBRICK FUSE COVER MY17 IMPL	1
3	90-02052	PREVAILING TORQUE TYPE NUT DIN 985 M4-08 ZM-F-01 REV 03	1
4	90-02102	WASHER UNIVERSAL (SIZE 1)	1
5	90-02052	PREVAILING TORQUE TYPE NUT DIN 985 M4-08 ZM-F-01 REV 03	1
6	90-02512	HEXAGON SOCKET HEAD CAP SCREW ISO 4762 M4X16-8.8 ZM-F-01 REV 03	1
7	90-08088	CONTACTOR O-RING	1
8	90-02101	WASHER ISO 7089 5-200HV ZM-F-01 REV 02	1
9	90-07125	HEXAGON SOCKET BUTTON HEAD SCREW ISO 7380 M5X10	1
10	90-07125	HEXAGON SOCKET BUTTON HEAD SCREW ISO 7380 M5X10	1
11	46-08104	CURRENT SENSOR BUS BAR ASSEMBLY LONGBRICK	1
12	40-08069	BMS PCB ASSY LONG BRICK POTTED 17MY IMPL	1
13	90-07389	BMS MOUNTING SCREW NEXT TO DIA CONNECTOR	1
14	90-07127	HEXAGON SOCKET HEAD CAP SCREW ISO 4762 M4X5-8.8 ZM-F-01 REV 03 ZM-L-02 REV 01	1
15	46-08096	LONGBRICK BMS COVER	1
16	80-08003	BATTERY FRONT UPPER FILLER PLUG	1
17	90-07126	HEXAGON SOCKET HEAD CAP SCREW ISO 4762 M4X8-8.8 ZM-F-01 REV 03 ZM-L-02 REV 01	1
18	90-02052	PREVAILING TORQUE TYPE NUT DIN 985 M4-08 ZM-F-01 REV 03	1
19	90-02102	WASHER UNIVERSAL (SIZE 1)	1
20	90-07126	HEXAGON SOCKET HEAD CAP SCREW ISO 4762 M4X8-8.8 ZM-F-01 REV 03 ZM-L-02 REV 01	1
21	90-02102	WASHER UNIVERSAL (SIZE 1)	1
22	45-08104	ELECTRICAL COMPONENT EVC135 CONTACTOR END MT NOTE: Longbrick	1
23	46-08145	ASSY BATTERY PACK LONGBRICK GIGAVAC 17MY NOTE: Please supply VIN, Case or Claim Number when ordering.	1
24	90-02140	CLIP-ON U-NUT M5X15.8DP	1
25	46-08091	BATTERY LOW VOLTAGE FUSE COVER	1
26	90-07288	HEXAGON SOCKET HEAD CAP SCREW ISO 4762 M5X12-8.8 ZM-F-01 REV 03 ZM-L-01 REV 01	1
27	46-08080	HV BATTERY CONNECTOR CLIP	1
28	PA-240	FUSE	1

29	45-08110	CONNECTOR STRAIN RELIEF PLATE SB SMART LB	1
30	PA-241	CABLE SUPPORT UPPER	1
31	<i>Not Applicable to this Bike Model</i>		
32	90-02480	WASHER ISO 7089 3-200HV ZM-F-01 REV 02	1
33	90-08046	HEXAGON SOCKET HEAD CAP SCREW ISO 4762 M3X12-8.8 ZM-F-01 REV 03 ZM-L-02 REV 01	1
34	3101-012	BATTERY LOW VOLTAGE FUSE HOLDER	1
35	26-08138	MOUNTING BRACKET XMX LONGBRICK FRONT	1
36	90-02101	WASHER ISO 7089 5-200HV ZM-F-01 REV 02	1
37	90-07272	HEXAGON SOCKET BUTTON HEAD CAP SCREW ISO 7380 M5X8-8.8 ZM-F-01 REV 03 ZM-L-02 REV 01	1
38	24-05783	XMX CONTROLLER FORMEX TOP	1
39	40-08145	ASSY MBB POTTED GEN2 STEP E NOTE: Please provide VIN, Case or Claim Number when ordering to ensure proper programming. NOTE: Supersedes 40-08071.	1
40	60-07190	DC-DC CONV 500W SEVCON 622-11211 ABS UNITS	1
41	45-02692	KEYSWITCH LOCK ZADI, IGNITION SWITCH NOTE: This part is the ignition switch and keys only. If you want a matching helmet lock for 16MY motorcycles and older, please order p/n 20-05202. If you want the key switch and a lock for a tank trunk, please order 27-08030. If you want a ignition and matching locks for tank trunk and storage trunks, please order part number 27-08044.	1
42	90-02937	M8X14MM BREAK AWAY HEX BOLT NOTE: One Time Use Bolt	1
43	90-02102	WASHER UNIVERSAL (SIZE 1)	1
44	90-02052	PREVAILING TORQUE TYPE NUT DIN 985 M4-08 ZM-F-01 REV 03	1
45	90-02102	WASHER UNIVERSAL (SIZE 1)	1
46	90-02052	PREVAILING TORQUE TYPE NUT DIN 985 M4-08 ZM-F-01 REV 03	1
47	45-02413	HALL SENSOR SIDESTAND SWITCH	1
48	PA-243	KICKSTAND SWITCH SCREW	1
49	90-02052	PREVAILING TORQUE TYPE NUT DIN 985 M4-08 ZM-F-01 REV 03	1
50	90-02104	WASHER ISO 7089 -8-200 HV ZM-F-01 REV 02	1
51	90-02054	PREVAILING TORQUE TYPE NUT DIN 985 M6-8 ZM-F-01 REV 02	1
52	90-02103	WASHER ISO 7089 6-200HV ZM-F-01 REV 02	1
53	60-07009	CONTROLLER, SIZE 4 GEN 4.5 SEVCON	1
54	90-02103	WASHER ISO 7089 6-200HV ZM-F-01 REV 02	1
55	90-03251	HEXAGON SOCKET HEAD CAP SCREW ISO 4762 M6X30-8.8 ZM-F-01 REV 03	1
56	20-06553	XMX HEATSINK MY14	1



57	90-07269	HEXAGON SOCKET HEAD CAP SCREW ISO 4762 M8X30-10.9 ZM-F-01 REV 03 ZM-L-01 REV 01	1
58	20-05036	HEAT SINK MOUNT	1
59	90-02071	HEXAGON NUT ISO 4032 M6-8 ZM-F-01 REV 02	1
60	90-02103	WASHER ISO 7089 6-200HV ZM-F-01 REV 02	1
61	45-06774	DISC HORN K70/H12 V WITH BLACK ZINC	1
62	26-08041	CHASSIS STRUCTURE MOUNTING BRACKET HORN	1
63	90-07285	HEXAGON FLANGE BOLT DIN 6921 OR ISO 4162 M5X16 ZM-F-01 REV 03 ZM-L-01 REV 01	1
64	90-02071	HEXAGON NUT ISO 4032 M6-8 ZM-F-01 REV 02	1
65	45-04864	CAVITY PLUG C13	1
66	90-07265	HEXAGON SOCKET HEAD CAP SCREW ISO 4762 M6X20-8.8 ZM-F-01 REV 03 ZM-L-01 REV 01	1
67	90-02103	WASHER ISO 7089 6-200HV ZM-F-01 REV 02	1
68	90-02071	HEXAGON NUT ISO 4032 M6-8 ZM-F-01 REV 02	1
69	90-02054	PREVAILING TORQUE TYPE NUT DIN 985 M6-8 ZM-F-01 REV 02	1
70	90-02103	WASHER ISO 7089 6-200HV ZM-F-01 REV 02	1
71	26-08040	DASH SUPPORT BRACKET STEEL	1
72	40-08030	DASH LCD (ABS) BUG LOGO NOTE: Applicable 14MY-18MY	1
73	PA-244	BRAKE LIGHT SWITCH	1
74	90-02103	WASHER ISO 7089 6-200HV ZM-F-01 REV 02	1
75	40-08089	CALEX CHARGER ASSEMBLY 720W REG 10.5 EMC COMPLIANT NOTE: Supersedes part number 40-07488.	1
76	90-07265	HEXAGON SOCKET HEAD CAP SCREW ISO 4762 M6X20-8.8 ZM-F-01 REV 03 ZM-L-01 REV 01	1
77	<i>Not Applicable to this Bike Model</i>		
78	<i>Not Applicable to this Bike Model</i>		
79	60-07780	LEFT HAND SWITCHGEAR ECIE	1
80	40-06054	KILL MODE START SWITCH	1
81	45-08039	THROTTLE BITRON HALL EFFECT PCB NOTE: Supersedes 27-08000	1