

Zero Motocycles

DS 2017 Exploded Views

ZEV0031 - Lighting

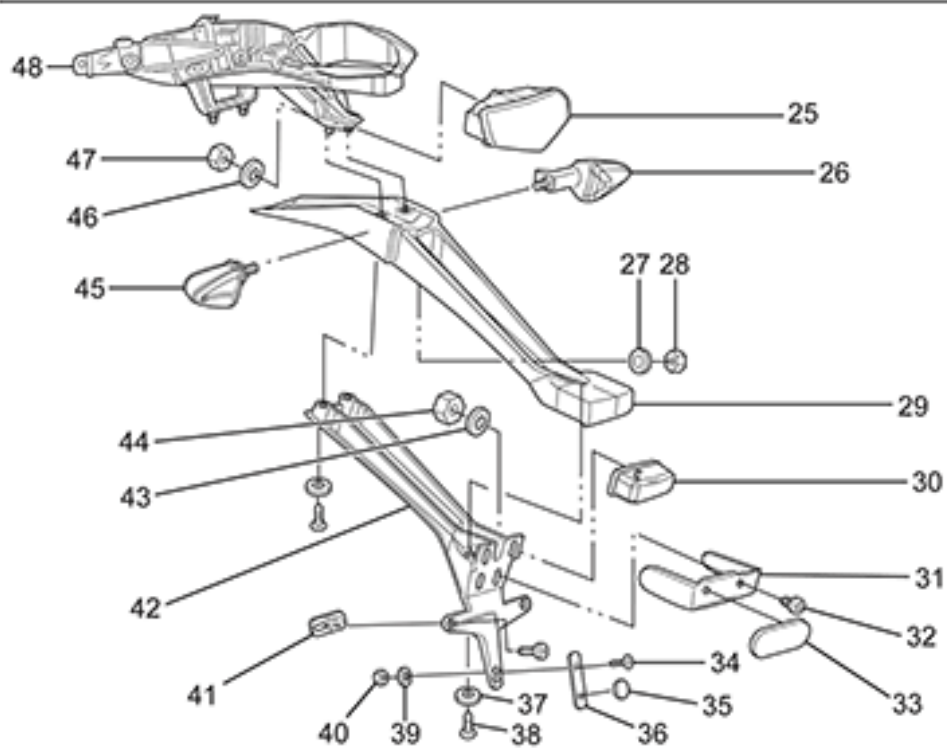
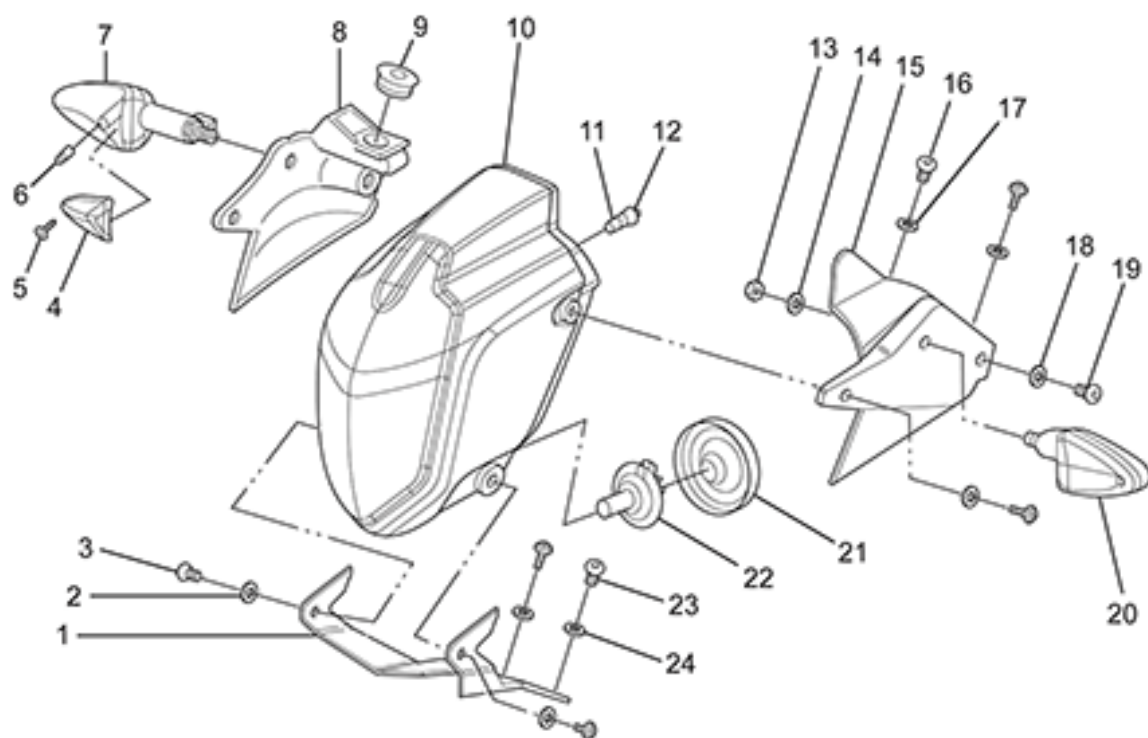

ZEV0031 - Lighting

Callout	Part Number	Part Name	Qty. per Motorcycle
1	20-05910	HEADLIGHT BRACKET	1
2	90-02101	WASHER ISO 7089 5-200HV ZM-F-01	4
3	90-07281	HEXAGON SOCKET BUTTON HEAD SCREWS ISO 7380 M6X12-8.8 ZM-F-01 REV 03 ZM-L-01 REV 01	1
4	PA-335	TURN SIGNAL LENS	1
5	PA-336	TURN SIGNAL LENS SCREW	1
6	65-08016	TURN SIGNAL BULB 12v ry 10w	1
7	65-03462	TURN SIGNAL FR-RH RR-LH	1
8	24-08091	HEADLIGHT MOUNT RIGHT FOR ABS	1
9	27-08034	12V ACCESSORY COVER, SMALL	1
10	45-03679	HEADLIGHT ASSY, 60/55W, TRIOM	1
11	65-08016	TURN SIGNAL BULB 12v ry 10w	1
12	PA-337	RUNNING LAMP BULB SOCKET/HARNESS	1
13	90-02072	HEXAGON THIN NUT DIN 439-B M10 1.5-04 ZM-F-01	2
14	90-02043	TOOTHED LOCK WASHER WITH EXTERNAL TEETH DIN 6797 A M10-B85 ZM-F-01	2
15	24-08092	HEADLIGHT MOUNT LEFT FOR ABS	1
16	90-04084	HEXAGON SOCKET BUTTON HEAD CAP SCREW ISO 7380 M5X16-8.8 ZM-F-11 REV 03	4
17	90-04085	WASHER M5 X 11 X 1 NYLON 6/6 BLACK	4
18	90-04085	WASHER M5 X 11 X 1 NYLON 6/6 BLACK	4
19	90-04084	HEXAGON SOCKET BUTTON HEAD CAP SCREW ISO 7380 M5X16-8.8 ZM-F-11 REV 03	4
20	65-03463	TURN SIGNAL FR-LH RR-RH	1
21	PA-338	HEADLAMP BULB SEAL	1
22	65-08002	SDS HEADLIGHT BULB	1
23	90-07281	HEXAGON SOCKET BUTTON HEAD SCREWS ISO 7380 M6X12-8.8 ZM-F-01 REV 03 ZM-L-01 REV 01	2
24	90-02101	WASHER ISO 7089 5-200HV ZM-F-01	4
25	65-04459	LED TAIL LIGHT TRIOM	1
26	65-03463	TURN SIGNAL FR-LH RR-RH	1
27	90-02043	TOOTHED LOCK WASHER WITH EXTERNAL TEETH DIN 6797 A M10-B85 ZM-F-01	2
28	90-02072	HEXAGON THIN NUT DIN 439-B M10 1.5-04 ZM-F-01	2
29	24-04439	SDS TAIL POD TOP NOTE: Top half only. Order bottom half PN: 24-05158	1
30	65-04460	LICENSE PLATE LIGHT	1
31	24-05159	REFLECTOR MOUNT BRACKET	1
32	90-05885	PHILIPS HEAD SHEET METAL SCREW 6 X 1/2	10
33	20-03487	REFLECTOR, OVAL, ADH BACK, RED ECIE	1

34	90-05244	HEXAGON SOCKET COUNTERSUNK HEAD SCREW ISO 10642 M5X12-10.9 ZM-F-01 REV 03	4
35	20-05241	LICENSE PLATE BUMPER	1
36	24-05292	LICENSE PLATE BRACKET EXTENSION LOWER NOTE: ONLY USED IN EU/AUS REGION	1
37	90-02103	WASHER ISO 7089 6-200HV ZM-F-01	10
38	90-07281	HEXAGON SOCKET BUTTON HEAD SCREWS ISO 7380 M6X12-8.8 ZM-F-01 REV 03 ZM-L-01 REV 01	2
39	90-04085	WASHER M5 X 11 X 1 NYLON 6/6 BLACK	4
40	90-02053	PREVAILING TORQUE TYPE NUT DIN 985 M5-08 ZM-F-01 REV 02	8
41	24-05161	LICENSE PLATE BRACKET EXTENSIONS NOTE: ONLY USED IN EU/AUS REGIONS	2
42	24-05158	SDS TAIL POD BOTTOM NOTE: Bottom half only. Order top half PN: 24-04439	1
43	90-07389	TOOTHED LOCK WASHER WITH EXTERNAL TEETH DIN 6797 A M5 ZM-F-01	4
44	90-02053	PREVAILING TORQUE TYPE NUT DIN 985 M5-08 ZM-F-01 REV 02	8
45	65-03462	TURN SIGNAL FR-RH RR-LH	1
46	90-02103	WASHER ISO 7089 6-200HV ZM-F-01	10
47	90-02054	PREVAILING TORQUE TYPE NUT DIN 985 M6-08 ZM-F-01	4
48	20-04876	SDS TAIL FRAME	1

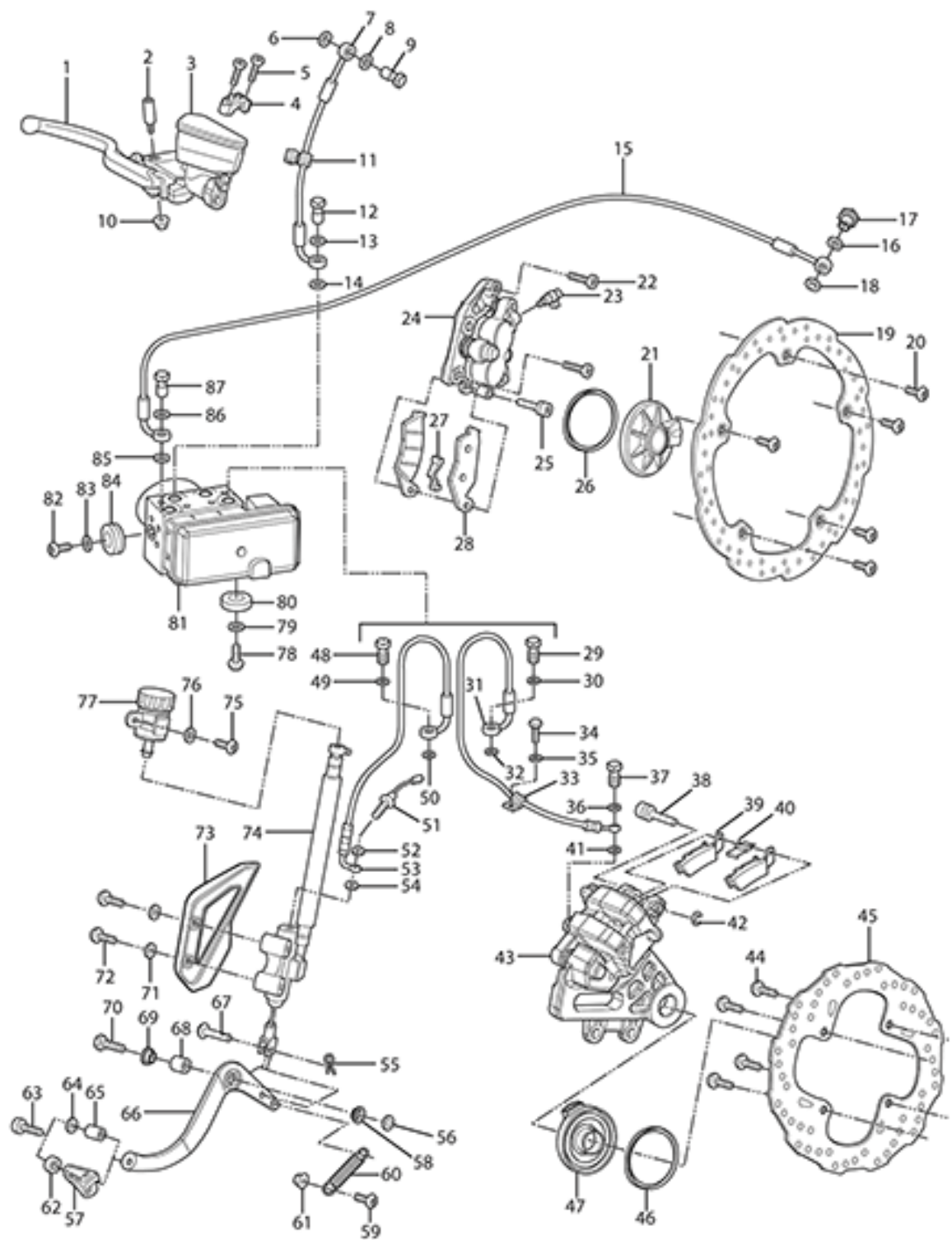

ZEV0032 - Braking

Callout	Part Number	Part Name	Qty. per Motorcycle
1	25-08032	SDS BRAKE JJUAN LEVER NOTE: Superseded by 25-08199	1
2	PA-177	BRAKE LEVER PIVOT BOLT	1
3	25-07682	JJUAN 12.7MM FRONT MASTER CYLINDER SDS/FXS	1
3	25-08035	JJUAN FRONT MC RESERVOIR CAP SERVICE KIT SDS	1
3	25-08044	FRONT MASTER CYLINDER BRAKE LIGHT SWITCH SDS	1
3	25-08051	JJUAN CALIPER/MASTER CYLINDER BLEED SCREW SDS/XMX	1
3	25-08061	JJUAN FRONT MASTER CYLINDER PISTON KIT SDS	1
3	25-08042	JJUAN FRONT MASTER CYLINDER CIRCLIP SDS/XMX	1
4	25-08064	FRONT MASTER CYLINDER CLAMP KIT NOTE: SDS/XMX NOTE: Mount and Bolts NOTE: Upper Mirror Mount RH	1
5	PA-178	MIRROR POST BOLT 6M X 20	1
6	PA-128	BANJO GASKET	1
7	25-07824	SDS FRONT BRAKE LINE MC TO HCU	1
8	PA-128	BANJO GASKET	1
9	PA-237	MASTER CYLINDER BANJO BOLT	1
10	PA-130	BRAKE LEVER PIVOT BOLT NUT	1
11	25-08023	BRAKE LINE/WHEEL SPEED SENSOR WIRE DOUBLE C CLIP	1
12	PA-180	BANJO BOLT	1
13	PA-128	BANJO GASKET	1
14	PA-128	BANJO GASKET	1
15	25-08096	DS FRONT BRAKE LINE HCU TO CALIPER	1
16	PA-128	BANJO GASKET	1
17	PA-181	BANJO BOLT	1
18	PA-128	BANJO GASKET	1
19	25-07702	BRAKE ROTOR 320MM FIXED NOTE: REPLACED BY 25-08169	1
20	90-07833	CUSTOM ROTOR BOLT M8X23MM SHOULDER SCREW	1
21	45-07496	MPI WHEEL SPEED SENSOR	1
22	90-08029	HEXAGON HEAD SCREW ISO 4762 M10-1.25X40-10.9 ZM-F-01 REV03 ZM-L-01 REV01	1
23	PA-182	BLEEDER VALVE	1
24	25-07686	JJUAN 32/30MM FRONT CALIPER SDS	1
25	90-08029	HEXAGON HEAD SCREW ISO 4762 M10-1.25X40-10.9 ZM-F-01 REV03 ZM-L-01 REV01	1
26	25-08080	ABS MAGNET RING	1
27	PA-183	ANTI RATTLE CLIP	1

28	25-08029	BRAKE PADS SET FRONT SDS	1
29	PA-185	BANJO BOLT	1
30	PA-128	BANJO GASKET	1
31	25-08093	SDS REAR BRAKE LINE HCU TO CALIPER NOTE: Supersedes part number 25-07821.	1
32	PA-128	BANJO GASKET	1
33	20-01758	LOOP CLAMP NYLON 3/4" BLK	1
34	90-07292	HEXAGON SOCKET BUTTON HEAD CAP SCREW ISO 7380 M5X16-8.8 ZM-F-11 REV 01 ZM-L-01 REV 01 NOTE: Does not apply to DS	1
35	90-02105	WASHER ISO 7093-1 6-200 HV ZM-F-01	1
36	PA-128	BANJO GASKET	1
37	PA-186	BANJO BOLT AT REAR CALIPER	1
38	PA-187	CALIPER SLIDE BOLT	1
39	25-08030	BRAKE PAD SET SDS REAR	1
40	PA-189	ANTI RATTLE CLIP	1
41	PA-128	BANJO GASKET	1
42	PA-190	CALIPER SLIDE BOLT CLIP	1
43	25-08099	JJUAN 34MM REAR CALIPER NOTE: Old Part P/N: 25-08083	1
44	90-07516	REAR BRAKE ROTOR BOLT NOTE: Supersedes 90-08015.	1
45	25-08170	BRAKE ROTOR 240MM REAR	1
46	25-08080	ABS MAGNET RING	1
47	45-07496	MPI WHEEL SPEED SENSOR	1
48	PA-191	BANJO BOLT AT HCU	1
49	PA-128	BANJO GASKET	1
50	PA-128	BANJO GASKET	1
51	25-08039	REAR STOP LAMP SWITCH	1
52	PA-128	BANJO GASKET	1
53	25-07820	SDS REAR BRAKE LINE MC TO HCU	1
54	PA-128	BANJO GASKET	1
55	90-02133	1/4 X 3/4 CLEVIS PIN STEEL ZINC	1
56	90-02100	WASHER ISO 7089 10-200 HV ZM-F-01	1
57	25-08072	BRAKE PEDAL OFF ROAD PEG	1
58	20-02465	IGLIDE BEARING GFM-1416-06	1
59	90-07323	HEXAGON SOCKET BUTTON HEAD CAP SCREW ISO 7380 M6X25-8.8 ZM-F-01 REV 03 ZM-L-01 REV 01	1
60	25-08070	BRAKE PEDAL SPRING	1
61	90-02054	PREVAILING TORQUE TYPE NUT DIN 985 M6-08 ZM-F-01	1
62	20-02455	X BRAKE PEDAL SPACER	1
63	90-07265	HEXAGON SOCKET HEAD CAP SCREW ISO 4762 M6X20-8.8 ZM-F-01 REV 03 ZM-L-01 REV 01	1
64	<i>Not Applicable to this Bike Model</i>		
65	<i>Not Applicable to this Bike Model</i>		

		BRAKE PEDAL BASE	
66	25-08071	NOTE: Brake Pedal Off Road Peg - 25-08072 - sold seperately NOTE: Brake Pedal Street Peg - 25-08073 - sold seperately	1
67	90-02133	1/4 X 3/4 CLEVIS PIN STEEL ZINC	1
68	20-02455	X BRAKE PEDAL SPACER	1
69	20-02465	IGLIDE BEARING GFM-1416-06	1
70	90-07318	HEXAGON FLANGE BOLT DIN 6921 M10X35 10.9 ZM-F-01 REV 03 ZM-L-01 REV 01	1
71	90-02103	WASHER ISO 7089 6-200HV ZM-F-01	1
72	90-07323	HEXAGON SOCKET BUTTON HEAD CAP SCREW ISO 7380 M6X25-8.8 ZM-F-01 REV 03 ZM-L-01 REV 01	1
73	25-07457	MASTER CYLINDER GUARD FOR J-JUAN MASTER CYLINDER	1
74	25-08015	JJUAN 12MM REAR MASTER CYLINDER SDS	1
74	25-08037	JJUAN REAR MC PUSHROD SERVICE KIT SDS/XMX	1
74	25-08040	JJUAN REAR MC RESERVOIR HOSE SERVICE KIT SDS	1
74	25-08062	JJUAN REAR MASTER CYLINDER PISTON KIT SDS	1
74	25-08067	JJUAN REAR MASTER CYLINDER CIRCLIP SDS/XMX	1
75	90-07323	HEXAGON SOCKET BUTTON HEAD CAP SCREW ISO 7380 M6X25-8.8 ZM-F-01 REV 03 ZM-L-01 REV 01	1
76	PA-196	WASHER	1
77	25-08036	JJUAN REAR MC RESERVOIR CAP SERVICE KIT SDS/XMX	1
78	90-07273	HEXAGON SOCKET BUTTON HEAD CAP SCREW ISO 7380 M6X16-8.8 ZM-F-01 REV 03 ZM-L-01 REV 01	1
79	90-02105	WASHER ISO 7093-1 6-200 HV ZM-F-01	1
80	90-08027	GROMMET VIBRATION ISOLATION M6	1
81	25-08092	BOSCH ABS HCU FLUID FILLED 6 PROFILE VARIANTS NOTE: Supersedes part number 25-08081 and 25-08082.	1
82	90-07273	HEXAGON SOCKET BUTTON HEAD CAP SCREW ISO 7380 M6X16-8.8 ZM-F-01 REV 03 ZM-L-01 REV 01	1
83	90-02105	WASHER ISO 7093-1 6-200 HV ZM-F-01	1
84	90-08027	GROMMET VIBRATION ISOLATION M6	1
85	PA-128	BANJO GASKET	1
86	PA-128	BANJO GASKET	1
87	PA-185	BANJO BOLT	1

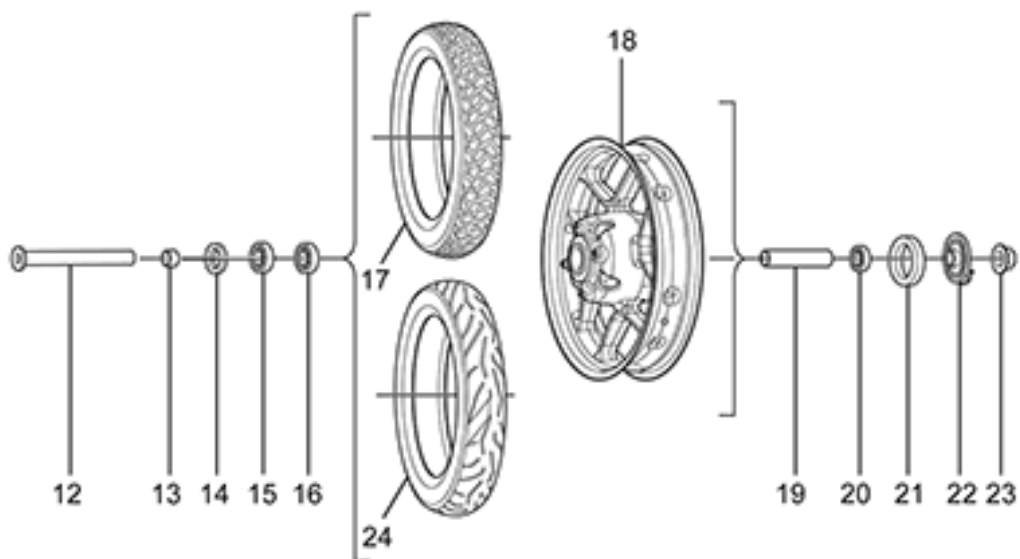
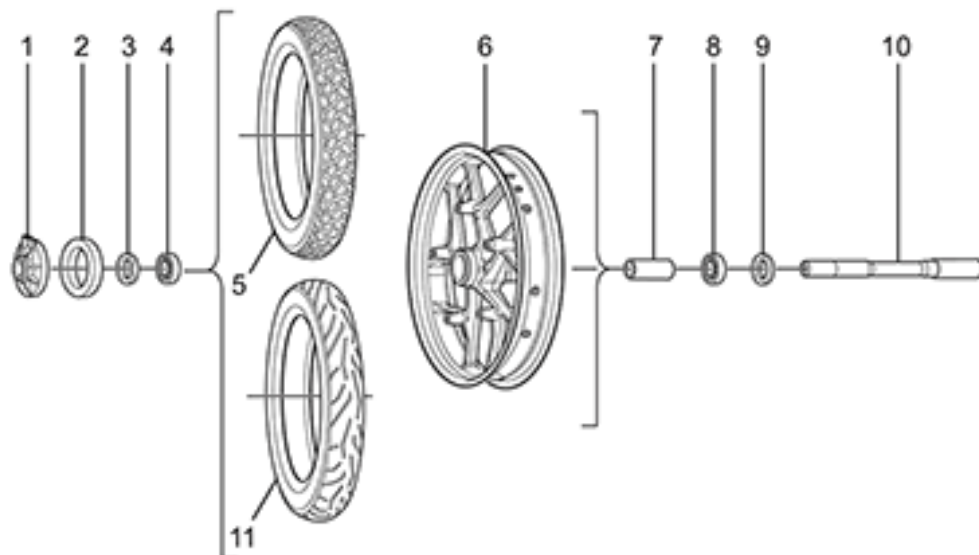

ZEV0033 - Wheel Assy

Callout	Part Number	Part Name	Qty. per Motorcycle
1	45-07496	MPI WHEEL SPEED SENSOR	1
2	25-08080	ABS MAGNET RING	1
3	23-07774	6204 BEARING DUST SEAL	2
4	20-06138	BEARING 6204 NOTE: Bearing used as swing arm bearing in some models and as the wheel bearing (qty of 5; 2 in front and three in rear wheel) in 2015 and later models. NOTE: Manufacturer part number is 6204-2RS	2
5	23-08002	TIRE, FRONT, 100/90-19 57H, PIRELLI MT-60	1
6	23-08066-4	2.50X19 DS FRONT CAST WHEEL ASSY SILVER BLACK	1
7	23-07775	FRONT WHEEL BEARING TUBE	1
8	20-06138	BEARING 6204 NOTE: Bearing used as swing arm bearing in some models and as the wheel bearing (qty of 5; 2 in front and three in rear wheel) in 2015 and later models. NOTE: Manufacturer part number is 6204-2RS	2
9	23-07774	6204 BEARING DUST SEAL	2
10	23-07491	HOLLOW AXLE FRONT	1
11	<i>Not Applicable to this Bike Model</i>		
12	23-08032	REAR AXLE 20MM HOLLOW, ROUNDED END	1
13	23-07489	WHEEL SPACER DRIVE SIDE REAR	1
14	23-07774	6204 BEARING DUST SEAL	2
15	20-06138	BEARING 6204 NOTE: Bearing used as swing arm bearing in some models and as the wheel bearing (qty of 5; 2 in front and three in rear wheel) in 2015 and later models. NOTE: Manufacturer part number is 6204-2RS	2
16	20-06138	BEARING 6204 NOTE: Bearing used as swing arm bearing in some models and as the wheel bearing (qty of 5; 2 in front and three in rear wheel) in 2015 and later models. NOTE: Manufacturer part number is 6204-2RS	2
17	23-08003	TIRE, REAR, 130/80-17 65H, PIRELLI MT-60	1
18	23-08056-4	WHEEL 3.50X17 SDS REAR CAST WHEEL ASSY 16MY IMPL BLACK-SILVER C	1
19	23-07776	REAR WHEEL BEARING TUBE 15MY	1
20	20-06138	BEARING 6204 NOTE: Bearing used as swing arm bearing in some models and as the wheel bearing (qty of 5; 2 in front and three in rear wheel) in 2015 and later models. NOTE: Manufacturer part number is 6204-2RS	2

21	25-08080	ABS MAGNET RING	1
22	45-07496	MPI WHEEL SPEED SENSOR	1
23	90-05678	U-NUT M20X1.5 FLANGE 27S 15H NOTE: Rear Axle Nut	1

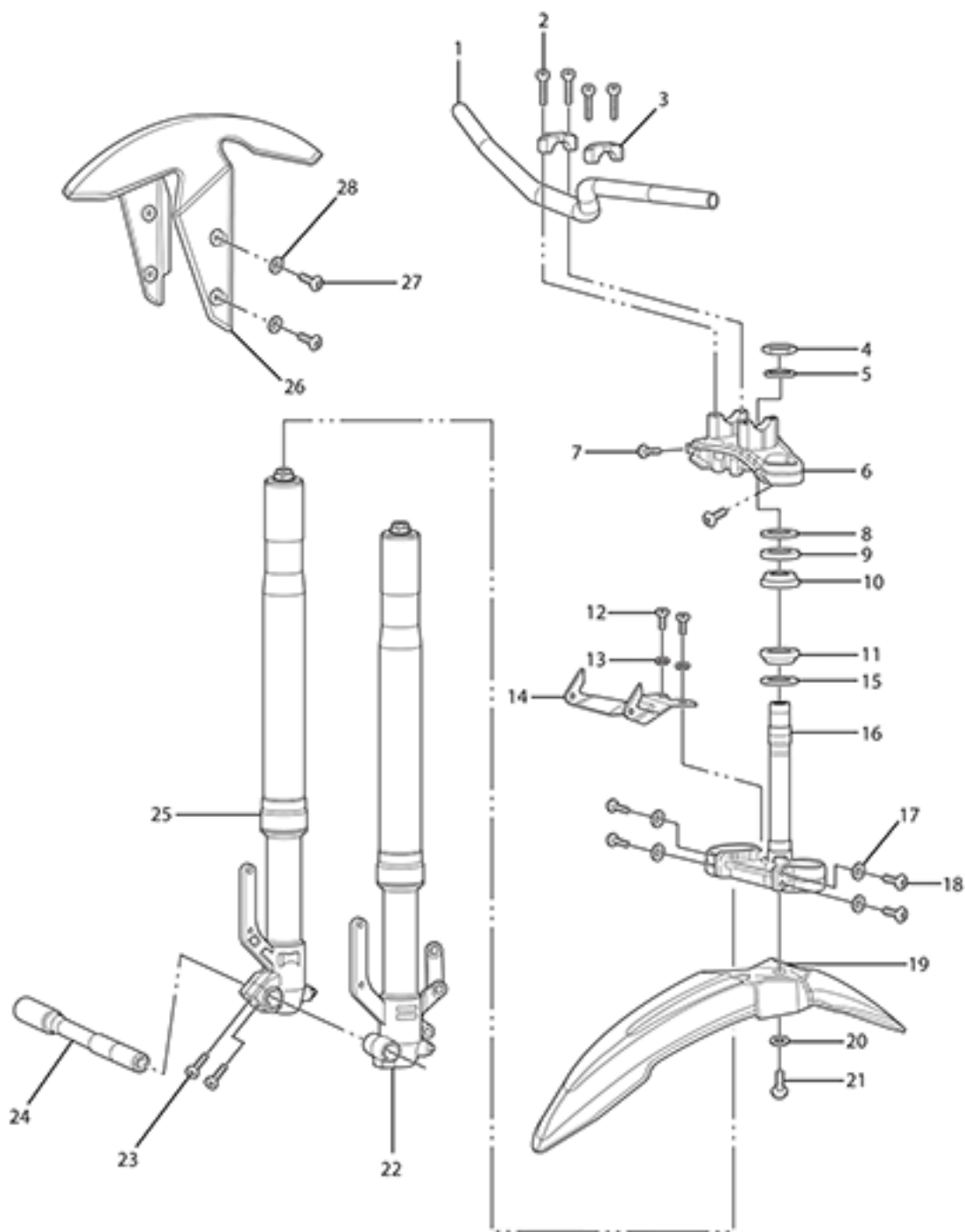

ZEV0034 - Steering Systems

Callout	Part Number	Part Name	Qty. per Motorcycle
1	27-08151	HIGH RISE HANDLEBAR NO LOGO NOTE: Supersedes part number 27-08050.	1
2	90-02096	MOTOR MOUNTING LEFT FRONT TOP AND LEFT FRONT BOTTOM BOLT	1
3	22-00687	S HANDLEBAR CLAMP	1
4	22-06279	STEERING STEM THIN NUT M27 X 1.5 X 8MM	1
5	20-06278	WASHER 41 - 27.5 X 2 MM	1
6	22-07622	SDS UPPER TRIPLE CLAMP 15MY IMP	1
7	90-02094	HEXAGON SOCKET HEAD CAP SCREW ISO 4762 M8X25-10.9 ZM-F-01 REV 03	1
8	22-06257	STEERING STEM LOCK NUT M 30 X1.5 MM	1
9	81-08045	BEARING LIP SEAL OVERMOLDED 55MM OD NOTE: Supersedes part 20-06113	1
10	20-06068	STEERING HEAD BEARING KOYO SAC3055-1	1
11	20-06068	STEERING HEAD BEARING KOYO SAC3055-1	1
12	90-02109	HEXAGON SOCKET BUTTON HEAD CAP SCREW ISO 7380 M5X12-8.8 ZM-F-01	1
13	90-02101	WASHER ISO 7089 5-200HV ZM-F-01	1
14	20-05910	HEADLIGHT BRACKET	1
15	81-08045	BEARING LIP SEAL OVERMOLDED 55MM OD NOTE: Supersedes part 20-06113	1
16	22-08092	SDS LOWER TRIPLE CLAMP ASSY NOTE: REPLACES 25-08082	1
17	90-02104	WASHER ISO 7089 -8-200 HV ZM-F-01	1
18	90-02094	HEXAGON SOCKET HEAD CAP SCREW ISO 4762 M8X25-10.9 ZM-F-01 REV 03	1
19	24-08191	FRONT FENDER DIRT BRAKE LINE HOLE	1
20	90-02107	WASHER ISO 7093-1 5-200HV ZM-F-01 NOTE: Does not apply to S and SR	1
21	90-07292	HEXAGON SOCKET BUTTON HEAD CAP SCREW ISO 7380 M5X16-8.8 ZM-F-11 REV 01 ZM-L-01 REV 01 NOTE: Does not apply to DS	1
22	22-05877	DS FORK 41MM LEFT	1
22	22-08053	DS FORK 41MM LEFT, LONGBRICK	1
23	90-07269	HEXAGON SOCKET HEAD CAP SCREW ISO 4762 M8X30-10.9 ZM-F-01 REV 03 ZM-L-01 REV 01	1
24	23-07491	HOLLOW AXLE FRONT	1
25	22-05878	DS FORK 41MM RIGHT	1
25	22-08052	DS FORK 41MM RIGHT, LONGBRICK	1

ZEV0035 - Body Trim

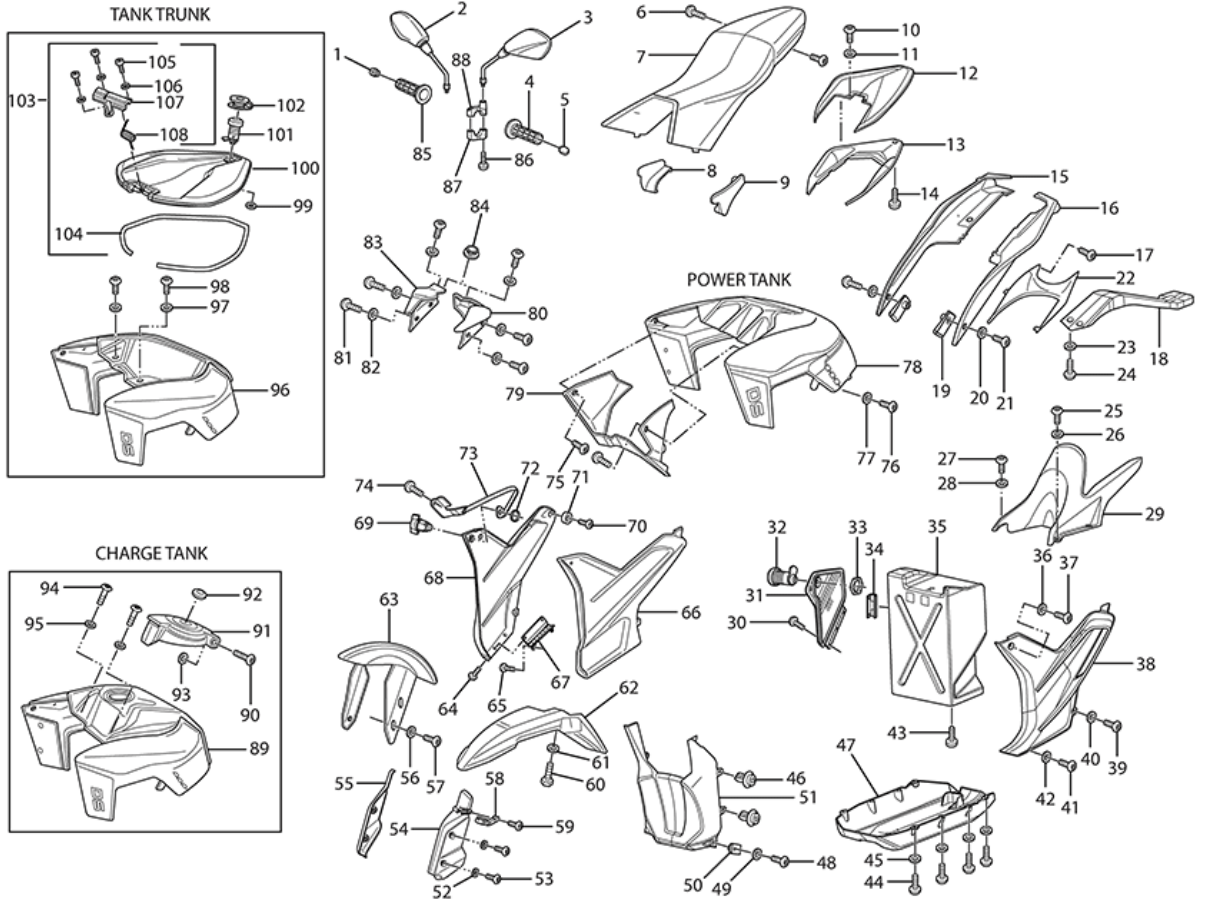

ZEV0035 - Body Trim

Callout	Part Number	Part Name	Qty. per Motorcycle
1	27-08002	HANDLEBAR END CAP	1
2	27-08057	MIRROR RH	1
3	27-08056	MIRROR LH	1
4	27-08083	HAND GRIP NON-THROTTLE SIDE NOTE: Grip does not have Zero logo. Order with 27-08082 if you want a matching pair. NOTE: Supersedes p/n 27-08007.	1
5	27-08002	HANDLEBAR END CAP	1
6	90-08005	SEAT BOLT M8X55 NOTE: Supersedes 90-07009.	1
7	27-08025	SDS SEAT ASSEMBLY MY15 NOTE: replaces 24-04854	1
8	24-08132	SEAT GAP FILLER RIGHT	1
9	24-08133	SEAT GAP FILLER LEFT	1
10	90-04716	HEXAGON SOCKET HEAD CAP SCREW ISO 4762 M4X8-8.8	1
11	90-02102	WASHER ISO 7089 4-200HV ZM-F-01	1
12	24-08098-17	Option #1: METALLIC BLACK	1
	24-08098-13	Option #2: BLACK	1
	24-08098-9	Option #3: RED	1
	24-08098-16	Option #4: SATIN SILVER	1
	24-08098-14	Option #5: GRAPHITE	1
	24-08098-19	Option #6: SATIN GREEN	1
	24-08098-25	Option #7: QUICKSAND	1
	24-08098-10	Option #8: YELLOW	1
	24-08098-12	Option #9: ORANGE	1
	24-08098-18	Option #10: PEARLESCENT WHITE	1
	24-08098-11	Option #11: WHITE	1
	24-08098-24	Option #12: JET BLACK	1
	24-08098-26	Option #13: METALLIC CHOCOLATE	1
13	24-08099-13	Option #1: BLACK	1
	24-08099-18	Option #2: PEARLESCENT WHITE	1
	24-08099-11	Option #3: WHITE	1
	24-08099-19	Option #4: SATIN GREEN	1
	24-08099-14	Option #5: GRAPHITE	1
	24-08099-12	Option #6: ORANGE	1
	24-08099-9	Option #7: RED	1
	24-08099-10	Option #8: YELLOW	1
	24-08099-16	Option #9: SATIN SILVER	1
	24-08099-17	Option #10: METALLIC BLACK	1
	24-08099-25	Option #11: QUICKSAND	1
	24-08099-24	Option #12: JET BLACK	1
	24-08099-26	Option #13: METALLIC CHOCOLATE	1

14	90-05885	PHILIPS HEAD SHEET METAL SCREW 6 X 1/2	1
15	24-08079	TRUNK PAN RIGHT COMPRESSION ADJUSTER TRIMMED	1
16	24-04435	TRUNK PAN LEFT	1
17	<i>Not Applicable to this Bike Model</i>		
18	24-04439	SDS TAIL POD TOP NOTE: Top half only. Order bottom half PN: 24-05158	1
19	90-02139	CLIP-ON U-NUT M5X11DP	1
20	90-04085	WASHER M5 X 11 X 1 NYLON 6/6 BLACK	1
21	90-07124	HEXAGON SOCKET BUTTON HEAD SCREW ISO 7380 M5X6-8.8	1
22	<i>Not Applicable to this Bike Model</i>		
23	90-02103	WASHER ISO 7089 6-200HV ZM-F-01	1
24	90-07281	HEXAGON SOCKET BUTTON HEAD SCREWS ISO 7380 M6X12-8.8 ZM-F-01 REV 03 ZM-L-01 REV 01	1
25	90-07124	HEXAGON SOCKET BUTTON HEAD SCREW ISO 7380 M5X6-8.8	1
26	90-04085	WASHER M5 X 11 X 1 NYLON 6/6 BLACK	1
27	90-07124	HEXAGON SOCKET BUTTON HEAD SCREW ISO 7380 M5X6-8.8	1
28	90-04085	WASHER M5 X 11 X 1 NYLON 6/6 BLACK	1
29	24-08251	TRIMMED REAR INNER FENDER	1
30	90-07125	HEXAGON SOCKET BUTTON HEAD SCREW ISO 7380 M5X10	1
31	12-08065	SDS LONGBRICK STORAGE DOOR REPLACEMENT KIT	1
32	12-08071	KEYED PANEL LATCH 90 DEG TURN REPLACEMENT KIT	1
33	90-08058	LATCH CYLINDER NUT	1
34	26-08173	LONG BRICK STORAGE BOX STRIKER PLATE	1
35	24-08237	SINGLE LONGBRICK STORAGE CONTAINER WITH STRIKE PLATE	1
36	90-04085	WASHER M5 X 11 X 1 NYLON 6/6 BLACK	1
37	90-04084	HEXAGON SOCKET BUTTON HEAD CAP SCREW ISO 7380 M5X16-8.8 ZM-F-11 REV 03	1
38	24-06684	SDS CHIN FAIRING LEFT NOTE: Please order 80-08012 DECAL/GRAPHIC/MEDALLION GRAPHIC, CRAFTED IN CALIFORNIA JEWEL separately.	1
39	90-04084	HEXAGON SOCKET BUTTON HEAD CAP SCREW ISO 7380 M5X16-8.8 ZM-F-11 REV 03	1
40	90-04085	WASHER M5 X 11 X 1 NYLON 6/6 BLACK	1
41	90-04084	HEXAGON SOCKET BUTTON HEAD CAP SCREW ISO 7380 M5X16-8.8 ZM-F-11 REV 03	1
42	90-04085	WASHER M5 X 11 X 1 NYLON 6/6 BLACK	1
43	90-07130	HEXAGON SOCKET HEAD CAP SCREW ISO 4762 M4X10-8.8 ZM-F-01 REV 03 ZM-L-01 REV 01	1
44	90-04084	HEXAGON SOCKET BUTTON HEAD CAP SCREW ISO 7380 M5X16-8.8 ZM-F-11 REV 03	1
45	90-04085	WASHER M5 X 11 X 1 NYLON 6/6 BLACK	1

46	90-08055	RIVET/TREE FASTENER 5MM OD PUSH SCREW TYPE	1
47	26-08051	SKID PLATE DS NOTE: Aluminum (5052-H32) skid plate used on Zero DS, Zero DSR and other SDS motorcycles in the authority configuration. Also used with the consumer drop bars, it is compatible with the Zero S and Zero SR. NOTE: Supersedes part number 20-05126.	1
48	90-04084	HEXAGON SOCKET BUTTON HEAD CAP SCREW ISO 7380 M5X16-8.8 ZM-F-11 REV 03	1
49	90-04085	WASHER M5 X 11 X 1 NYLON 6/6 BLACK	1
50	90-02140	CLIP-ON U-NUT M5X15.8DP	1
51	24-07674	SDS STUBBY CHIN CENTER	1
52	90-04085	WASHER M5 X 11 X 1 NYLON 6/6 BLACK	1
53	90-04084	HEXAGON SOCKET BUTTON HEAD CAP SCREW ISO 7380 M5X16-8.8 ZM-F-11 REV 03	1
54	24-08070	FORK GUARD LEFT	1
55	24-08069	FORK GUARD RIGHT	1
56	<i>Not Applicable to this Bike Model</i>		
57	<i>Not Applicable to this Bike Model</i>		
58	24-08071	FORK GUARD CLAMP	1
59	90-05887	PHILIPS HEAD SHEET METAL SCREW TYPE AB NO 10 X 1/2 STEEL ZM-F-11	1
60	90-07292	HEXAGON SOCKET BUTTON HEAD CAP SCREW ISO 7380 M5X16-8.8 ZM-F-11 REV 01 ZM-L-01 REV 01 NOTE: Does not apply to DS	1
61	90-02101	WASHER ISO 7089 5-200HV ZM-F-01	1
62	24-08191	FRONT FENDER DIRT BRAKE LINE HOLE	1
63	<i>Not Applicable to this Bike Model</i>		
64	90-04083	HEXAGON SOCKET BUTTON HEAD CAP SCREW ISO 7380 M5X6-8.8 ZM-F-11 REV 03	1
65	90-04084	HEXAGON SOCKET BUTTON HEAD CAP SCREW ISO 7380 M5X16-8.8 ZM-F-11 REV 03	1
66	24-08235	SDS CHIN FAIRING RIGHT NOTE: Please order 80-08012 DECAL/GRAPHIC/MEDALLION GRAPHIC, CRAFTED IN CALIFORNIA JEWEL separately.	1
67	26-08165	LONGBRICK STORAGE FAIRING HINGE ASSEMBLY	1
68	24-08223	REWORKED CHIN FAIRING RIGHT, CAM LOCK NOTE: NOTE: for Zero S/DS ZF6.5 and ZF7.2	1
69	27-08047	LONG BRICK FAIRING PANEL THUMB LOCK	1
70	90-08095	PHILIPS HEAD SHEET METAL SCREW TYPE AB NO 10 X 3/4" STEEL	1
71	24-08238	RECESSED WASHER RUBBER BUMPER 3/4" OD 9/16" TALL 3/16" COUNTERBORE	1
72	90-08058	LATCH CYLINDER NUT	1
73	26-08183	LONGBRICK STORAGE FAIRING TETHER ASSEMBLY	1

74	90-08103	HEXAGON SOCKET THIN HEAD CAP SCREW DIN 7984 M5X20-8.8	1
75	90-05887	PHILIPS HEAD SHEET METAL SCREW TYPE AB NO 10 X 1/2 STEEL ZM-F-11	1
76	90-04084	HEXAGON SOCKET BUTTON HEAD CAP SCREW ISO 7380 M5X16-8.8 ZM-F-11 REV 03	1
77	90-04085	WASHER M5 X 11 X 1 NYLON 6/6 BLACK	1
78	24-08109-14	Option #1: GRAPHITE	1
	24-08109-13	Option #2: BLACK	1
	24-08109-12	Option #3: ORANGE	1
	24-08109-11	Option #4: WHITE	1
	24-08109-19	Option #5: SATIN GREEN	1
	24-08109-17	Option #6: METALLIC BLACK	1
79	24-04428	SDS FAIRING FRONT CENTER BLACK#2	1
80	24-08092	HEADLIGHT MOUNT LEFT FOR ABS	1
81	90-04084	HEXAGON SOCKET BUTTON HEAD CAP SCREW ISO 7380 M5X16-8.8 ZM-F-11 REV 03	1
82	90-04085	WASHER M5 X 11 X 1 NYLON 6/6 BLACK	1
83	24-08091	HEADLIGHT MOUNT RIGHT FOR ABS	1
84	27-08034	12V ACCESSORY COVER, SMALL	1
85	27-08082	HAND GRIP THROTTLE SIDE NOTE: Grip does not have Zero logo. Order with 27-08083 if you want a matching pair. NOTE: Supersedes p/n 27-08006.	1
86	90-07265	HEXAGON SOCKET HEAD CAP SCREW ISO 4762 M6X20-8.8 ZM-F-01 REV 03 ZM-L-01 REV 01	1
87	24-02961	MIRROR MOUNT CLAMP	1
88	26-08060	MIRROR LH MOUNT LOW PROFILE NOTE: Bottom part of the mirror mount LH	1
89	24-08269-11	Option #1: WHITE	1
	24-08269-12	Option #2: ORANGE	1
	24-08269-13	Option #3: BLACK	1
	24-08269-14	Option #4: GRAPHITE	1
90	90-08048	LATCH BOLT CYLINDER	1
91	24-08156	J1772 INLET COVER WITH BADGE ASSEMBLY	1
92	PA-339	J1772 INLET COVER BADGE	1
93	90-08083	LATCH BOLT SECURITY SCREW	1
94	90-07292	HEXAGON SOCKET BUTTON HEAD CAP SCREW ISO 7380 M5X16-8.8 ZM-F-11 REV 01 ZM-L-01 REV 01 NOTE: Does not apply to DS	1
95	90-04085	WASHER M5 X 11 X 1 NYLON 6/6 BLACK	1
		Option #1: METALLIC BLACK NOTE: Part is full assembly branded w/ Tank trunk lid, hinge and lock w/ key NOTE: comes w/ call out#'s 99-108 Option #2: WHITE	

NOTE: Part is full assembly branded w/ Tank trunk lid, hinge and lock w/ key
 NOTE: comes w/ call out#'s 99-108
 Option #3: ORANGE

NOTE: Part is full assembly branded w/ Tank trunk lid, hinge and lock w/ key
 NOTE: comes w/ call out#'s 99-108
 Option #4: BLACK

NOTE: Part is full assembly branded w/ Tank trunk lid, hinge and lock w/ key
 NOTE: comes w/ call out#'s 99-108
 Option #5: GRAPHITE

NOTE: Part is full assembly branded w/ Tank trunk lid, hinge and lock w/ key
 NOTE: comes w/ call out#'s 99-108
 Option #6: SATIN GREEN

NOTE: Part is full assembly branded w/ Tank trunk lid, hinge and lock w/ key
 NOTE: comes w/ call out#'s 99-108
 Option #7: QUICKSAND

NOTE: Part is full assembly branded w/ Tank trunk lid, hinge and lock w/ key
 NOTE: comes w/ call out#'s 99-108

97	90-04085	WASHER M5 X 11 X 1 NYLON 6/6 BLACK	1
98	24-08283-25 90-04084	HEXAGON SOCKET BUTTON HEAD CAP SCREW ISO 7380 M5X16-8.8 ZM-F-11 REV 03	1 1
99	90-08058 24-08283-19	LATCH CYLINDER NUT	1
100	24-08283-14 24-08192	TANK TRUNK LID NOTE: Tank Trunk Lid Only. Please order the complete service kit 12-08072 if all parts are needed. Kit is not backward compatible with earlier model years. NOTE: For older model years, please order the entire replacement tank assembly with tank trunk.	1 1
96	24-08283-13		1
101	12-08071	KEYED PANEL LATCH 90 DEG TURN REPLACEMENT KIT	1
102	12-08062 24-08283-12	90 DEG TURN KEYLATCH CAP	1
103	12-08072	TANK TRUNK LID REPLACEMENT KIT NOTE: Kit includes TANK TRUNK LID (24-08192).	1
Part Detail for #103.		TANK TRUNK LID REPLACEMENT KIT	1
Callout	Part Number	Part Name	Qty. per Motorcycle
104	24-08214	ASYMMETRIC U-CHANNEL FOAM SEAL 3/16" WIDE	1
105	90-08009	HEXAGON SOCKET HEAD CAP SCREW ISO 4762 M3X8-8.8 ZM-F-01 ZM-L-02	1
106	90-02480	WASHER ISO 7089 3-200HV ZM-F-01	1
107	24-08220	TANK TRUNK HINGE CAP	1

108	90-08077	TORSION SPRING FOR LID	1
-----	----------	------------------------	---

ZEV0036 - Rear Suspension

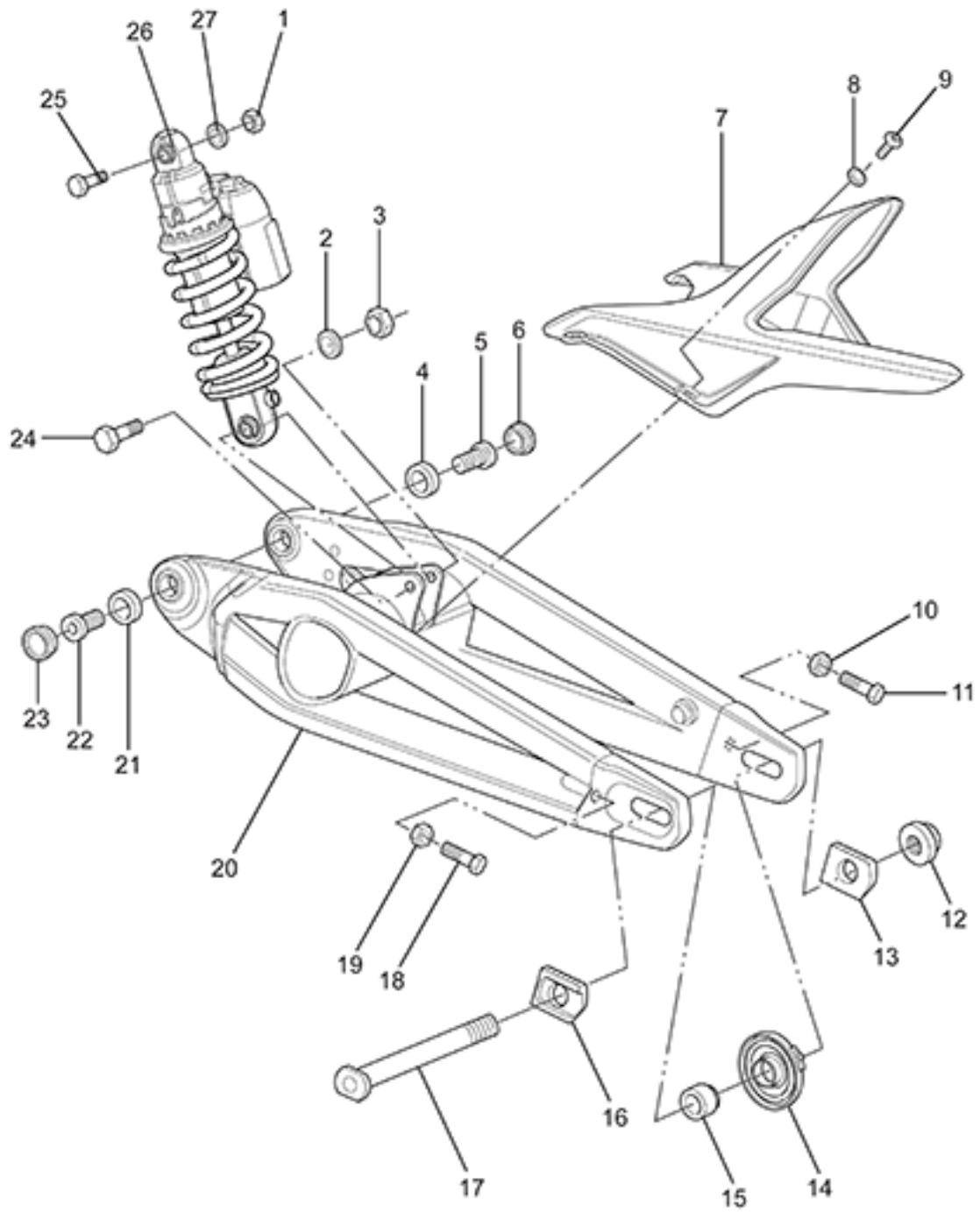

ZEV0036 - Rear Suspension

Callout	Part Number	Part Name	Qty. per Motorcycle
1	90-02050	PREVAILING TORQUE TYPE NUT DIN 985 M10-08 ZM-F-01	1
2	90-02100	WASHER ISO 7089 10-200 HV ZM-F-01	1
3	90-02050	PREVAILING TORQUE TYPE NUT DIN 985 M10-08 ZM-F-01	1
4	20-06138	BEARING 6204 NOTE: Bearing used as swing arm bearing in some models and as the wheel bearing (qty of 5; 2 in front and three in rear wheel) in 2015 and later models. NOTE: Manufacturer part number is 6204-2RS	2
5	20-06130	STUB AXLE	1
6	20-06937	SDS STUB-PIVOT COVER	1
7	24-08251	TRIMMED REAR INNER FENDER	1
8	90-04085	WASHER M5 X 11 X 1 NYLON 6/6 BLACK	1
9	90-02109	HEXAGON SOCKET BUTTON HEAD CAP SCREW ISO 7380 M5X12-8.8 ZM-F-01	1
10	90-05088	HEXAGON FLANGE NUT DIN 6923 M8-1.25 ZM-F-01 REV 03 NOTE: Axle adjusters jam nut	1
11	90-03030	HEXAGON HEAD SCREW DIN 933 M8X40-10.9 ZM-F-01 REV 03	1
12	90-05678	U-NUT M20X1.5 FLANGE 27S 15H NOTE: Rear Axle Nut	1
13	26-08123	REAR AXLE ADJUSTER PUSH BLOCK NUT SIDE	1
14	45-07496	MPI WHEEL SPEED SENSOR	1
15	23-07489	WHEEL SPACER DRIVE SIDE REAR	1
16	26-08124	REAR AXLE ADJUSTER PUSH BLOCK HEAD SIDE	1
17	23-08032	REAR AXLE 20MM HOLLOW, ROUNDED END	1
18	90-03030	HEXAGON HEAD SCREW DIN 933 M8X40-10.9 ZM-F-01 REV 03	1
19	90-05088	HEXAGON FLANGE NUT DIN 6923 M8-1.25 ZM-F-01 REV 03 NOTE: Axle adjusters jam nut	1
20	26-08069	S SWINGARM EXTENDED REAR AXLE SLOT	1
21	20-06138	BEARING 6204 NOTE: Bearing used as swing arm bearing in some models and as the wheel bearing (qty of 5; 2 in front and three in rear wheel) in 2015 and later models. NOTE: Manufacturer part number is 6204-2RS	2
22	20-06130	STUB AXLE	1
23	20-06937	SDS STUB-PIVOT COVER	1
24	90-05711	LOWER SHOCK EYE BOLT M10-1.5X60MM	1
25	90-05711	LOWER SHOCK EYE BOLT M10-1.5X60MM	1
26	22-05882	DS SHOCK 40MM	1

26	22-08054	DS SHOCK 40MM, LONGBRICK	1
27	90-02100	WASHER ISO 7089 10-200 HV ZM-F-01	1

ZEV0037 - Frame(Left)

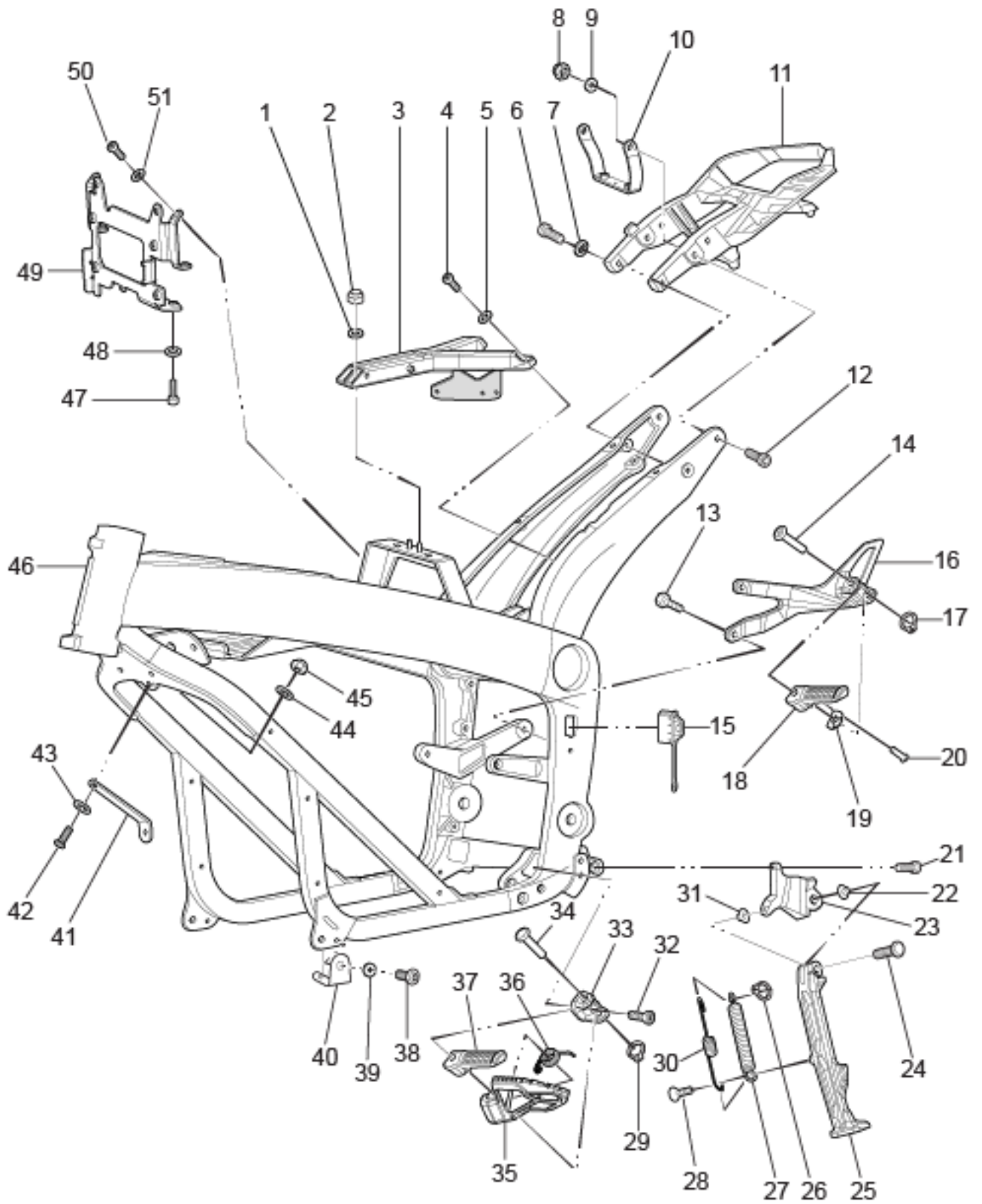

ZEV0037 - Frame(Left)

Callout	Part Number	Part Name	Qty. per Motorcycle
1	90-02103	WASHER ISO 7089 6-200HV ZM-F-01	1
2	90-02054	PREVAILING TORQUE TYPE NUT DIN 985 M6-08 ZM-F-01	1
3	21-06979	SDS SEAT FRAME WITH FUSEPANEL MOUNT	1
4	90-02122	HEXAGON SOCKET BUTTON HEAD CAP SCREW ISO 7380 M6X16-8.8 ZM-F-01 REV 03	1
5	90-02103	WASHER ISO 7089 6-200HV ZM-F-01	1
6	90-07269	HEXAGON SOCKET HEAD CAP SCREW ISO 4762 M8X30-10.9 ZM-F-01 REV 03 ZM-L-01 REV 01	1
7	90-02104	WASHER ISO 7089 -8-200 HV ZM-F-01	1
8	<i>Not Applicable to this Bike Model</i>		
9	<i>Not Applicable to this Bike Model</i>		
10	<i>Not Applicable to this Bike Model</i>		
11	20-04876	SDS TAIL FRAME	1
12	90-08005	SEAT BOLT M8X55 NOTE: Supersedes 90-07009.	1
13	90-07284	HEX FLANGE BOLT M8X25	1
14	90-02725	CLEVIS PIN CUSTOM 10MM X 45L	1
15	45-04864	AC CHARGE INLET COVER	1
16	20-04285	SDS PASSENGER PEG BRKT L	1
17	90-02879	RETAINING RING 9MM SHAFT DIN 471	1
18	27-08039	PASSENGER FOOTPEG LEFT SIDE	1
19	20-04279	FOOTPEG DETENT PLATE	1
20	20-05404	FOOTPEG DETENT BALL MECHANISM	1
21	90-07277	HEXAGON SOCKET THIN HEAD CAP SCREW DIN 7984 M10X25-8.8 ZM-F-01 REV 03 ZM-L-01 REV 01	1
22	90-02800	BUSHING FLANGE 0.375	1
23	20-06590	KICKSTAND MOUNT	1
24	90-02799	CLEVIS PIN CUSTOM NOTE: Used to attach kickstand leg to mount.	1
25	20-05661	MEDIUM KICKSTAND LEG W/MAGNET	1
26	90-02837	E CLIP 0.375	1
27	90-08219	SIDESTAND SPRING OUTER STAINLESS PASSIVATED	1
28	90-07261	HEXAGON SOCKET COUNTERSUNK HEAD SCREW ISO 10642 M8X20-10.9 ZM-F-01 REV 03 ZM-L-01 REV 01	1
29	90-02879	RETAINING RING 9MM SHAFT DIN 471	1
30	20-00709	S KS SPRING IN	1
31	90-02800	BUSHING FLANGE 0.375	1
32	90-07277	HEXAGON SOCKET THIN HEAD CAP SCREW DIN 7984 M10X25-8.8 ZM-F-01 REV 03 ZM-L-01 REV 01	1
33	20-02723	CLEVIS FOOT PEG UNIVERSAL LEFT	1

34	90-02725	CLEVIS PIN CUSTOM 10MM X 45L	1
35	20-02548	FOOTPEG, LEFT	1
36	20-02727	TORSION SPRING, .678 OD .078 WIRE, CCW	1
37	<i>Not Applicable to this Bike Model</i>		
38	90-04084	HEXAGON SOCKET BUTTON HEAD CAP SCREW ISO 7380 M5X16-8.8 ZM-F-11 REV 03	1
39	90-04085	WASHER M5 X 11 X 1 NYLON 6/6 BLACK	1
40	20-05307	SKID PAN BRACKET	1
41	20-07073	SDS FRAME MOUNTED HORN BRACKET	1
42	90-07435	HEX SOCKET BUTTON HEAD CAP SCREW M6X20-8.8	1
43	90-02103	WASHER ISO 7089 6-200HV ZM-F-01	1
44	90-02103	WASHER ISO 7089 6-200HV ZM-F-01	1
45	90-02054	PREVAILING TORQUE TYPE NUT DIN 985 M6-08 ZM-F-01	1
46	26-08127	S MAIN FRAME NOTE: Also for DS Main frame	1
47	90-07288	HEXAGON SOCKET HEAD CAP SCREW ISO 4762 M5X12-8.8 ZM-F-01 REV 03 ZM-L-01 REV 01	1
48	90-02101	WASHER ISO 7089 5-200HV ZM-F-01	1
49	26-08120	S ELECTRICAL PANEL	1
50	90-07288	HEXAGON SOCKET HEAD CAP SCREW ISO 4762 M5X12-8.8 ZM-F-01 REV 03 ZM-L-01 REV 01	1
51	90-02101	WASHER ISO 7089 5-200HV ZM-F-01	1

ZEV0038 - Frame(Right)

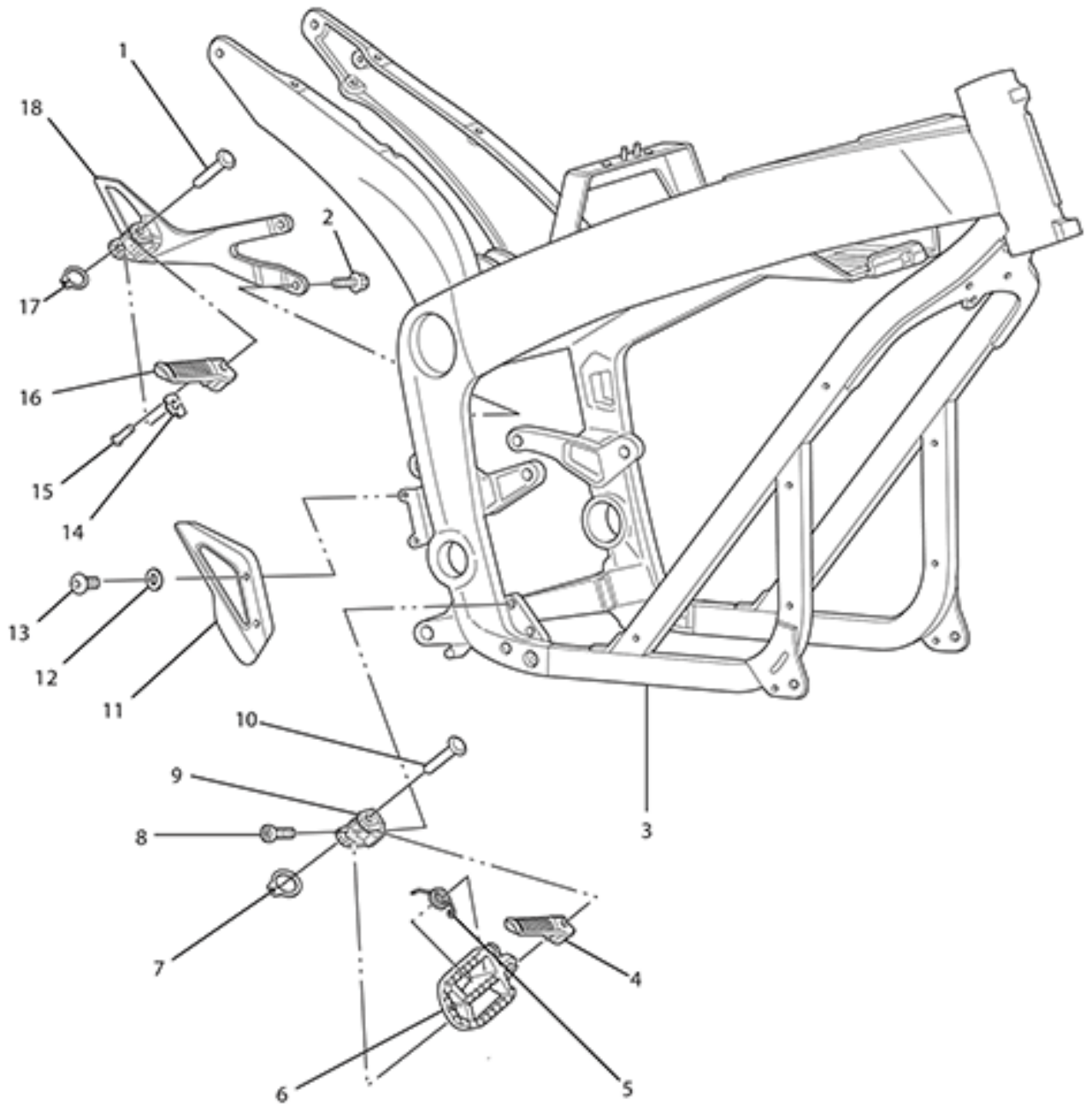

ZEV0038 - Frame(Right)

Callout	Part Number	Part Name	Qty. per Motorcycle
1	90-02725	CLEVIS PIN CUSTOM 10MM X 45L	1
2	90-07284	HEX FLANGE BOLT M8X25	1
3	26-08127	S MAIN FRAME NOTE: Also for DS Main frame	1
4	20-02548	FOOTPEG, LEFT	0
5	20-02727	TORSION SPRING, .678 OD .078 WIRE, CCW	1
6	20-02549	FOOTPEG, RIGHT NOTE: Does not apply to S and SR	1
7	90-02879	RETAINING RING 9MM SHAFT DIN 471	1
8	90-07277	HEXAGON SOCKET THIN HEAD CAP SCREW DIN 7984 M10X25-8.8 ZM-F-01 REV 03 ZM-L-01 REV 01	1
9	20-02724	CLEVIS FOOT PEG UNIVERSAL RIGHT	1
10	90-02725	CLEVIS PIN CUSTOM 10MM X 45L	1
11	25-07457	MASTER CYLINDER GUARD FOR J-JUAN MASTER CYLINDER	1
12	90-02103	WASHER ISO 7089 6-200HV ZM-F-01	1
13	90-07323	HEXAGON SOCKET BUTTON HEAD CAP SCREW ISO 7380 M6X25-8.8 ZM-F-01 REV 03 ZM-L-01 REV 01	1
14	20-04279	FOOTPEG DETENT PLATE	1
15	20-05404	FOOTPEG DETENT BALL MECHANISM	1
16	27-08038	PASSENGER FOOTPEG RIGHT SIDE	1
17	90-02879	RETAINING RING 9MM SHAFT DIN 471	1
18	20-07604	SDS AND FX PASSENGER PEG BRKT R	1

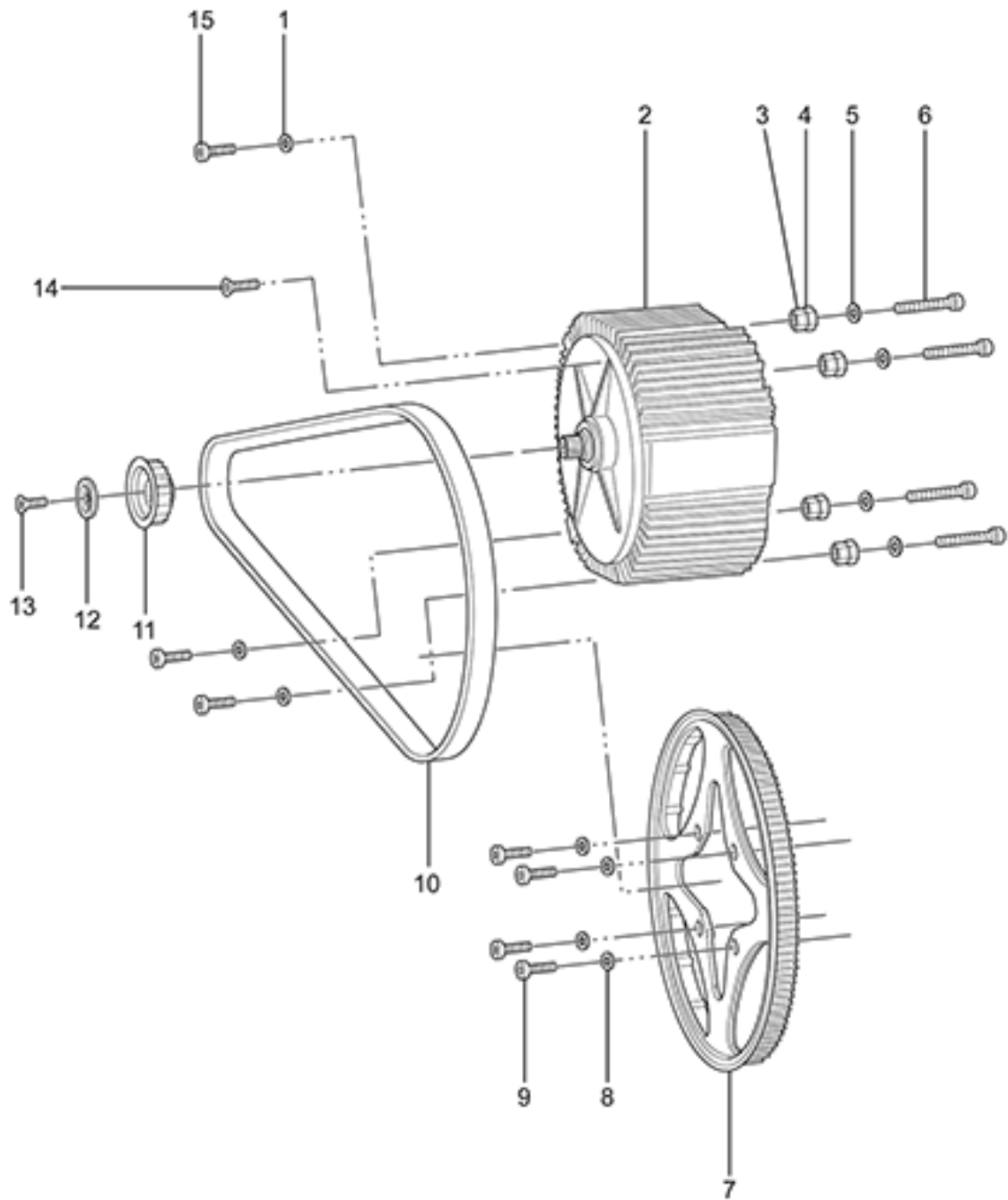

ZEV0039 - Motor and Drive System

Callout	Part Number	Part Name	Qty. per Motorcycle
1	90-02104	WASHER ISO 7089 -8-200 HV ZM-F-01	1
2	30-08099	ZF75-7 IPM MOTOR SPLINED SHAFT NOTE: Motor used in 2016 through 2019 S/DS ZF13.0 & ZF14.4	1
2	30-08107	ZF75-5 S IPM MOTOR SPLINED SHAFT NOTE: Motor used in 2016 through 2019 S/DS ZF6.5 & ZF7.2	1
3	20-04773	MOTOR JACK SCREW OUTER	4
4	20-04774	MOTOR JACK SCREW INNER	4
5	90-02104	WASHER ISO 7089 -8-200 HV ZM-F-01	4
6	90-05179	HEXAGON SOCKET HEAD CAP SCREW ISO 4762 M8X60-8.8 ZM-F-01 REV 03	1
7	30-08109	WHEEL SPROCKET 90T 11MM PITCH 17MM WIDE BELT COATED	1
8	90-02104	WASHER ISO 7089 -8-200 HV ZM-F-01	4
9	90-08053	HEXALOBULAR SOCKET PAN HEAD ISO 14583 M8X30-10.9 ZM-F-01 ZM-L-02	4
10	30-08278	BELT 158T 11MM PITCH 17MM WIDE THIN WEB NOTE: Supersedes 30-08086	1
11	30-08116	MOTOR SPROCKET 20T 11MM PITCH 17MM WIDE BELT ASSEMBLED	1
12	20-05453	LOW PROFILE BELT SPROCKET MOTOR SHAFT TOPHAT	1
13	90-02056	HEXAGON SOCKET COUNTERSUNK HEAD SCREW M10X25-8.8 MOTOR SHAFT NOTE: Bolt used to hold front sprocket in place onto the motor shaft. NOTE: Sprocket	1
14	90-08037	HEXALOBULAR (6 LOBE) SOCKET FLAT HEAD COUNTERSUNK SCREW ISO 14582 M8X30-10.9 ZM-F-01 REV 04	1
15	90-02096	MOTOR MOUNTING LEFT FRONT TOP AND LEFT FRONT BOTTOM BOLT	3

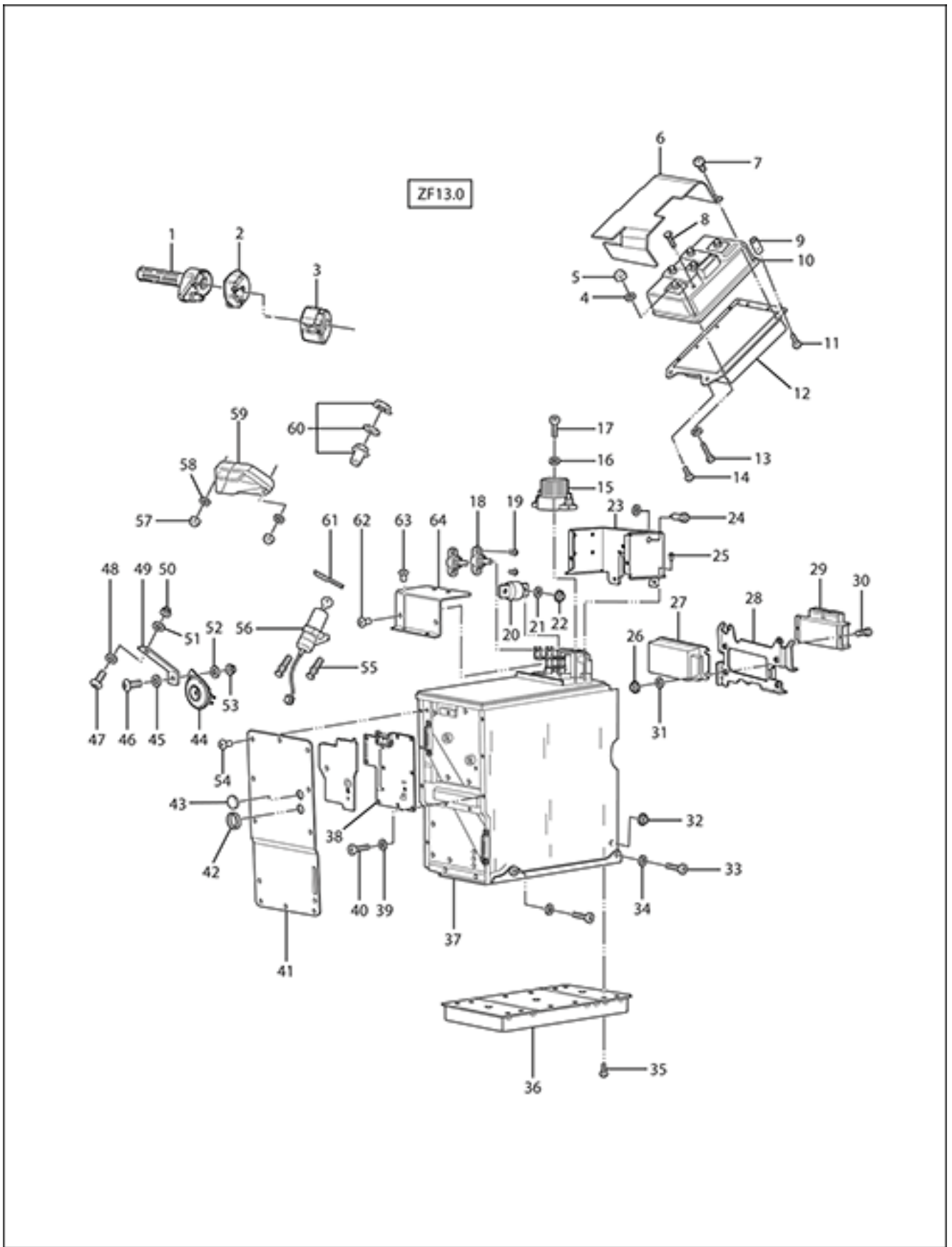

Callout	Part Number	Part Name	Qty. per Motorcycle
1	45-08039	THROTTLE BITRON HALL EFFECT PCB NOTE: Supersedes 27-08000	1
2	40-06054	KILL MODE START SWITCH	1
3	60-07780	LEFT HAND SWITCHGEAR ECIE	1
4	90-02103	WASHER ISO 7089 6-200HV ZM-F-01	1
5	90-02071	HEXAGON NUT ISO 4032 M6-8 ZM-F-01 REV 02	1
6	20-05634	#4 CONTROLLER COVER	1
7	90-06250	CONTROLLER FORMEX PAN HEAD PHILLIPS #6 SHEET METAL SCREW	1
8	90-07063	CONTROLLER LEAD BOLTS M8X16	1
9	20-03823	SDS SEVCON CONTROLLER MOUNT REAR BOLT SPACERS	1
10	60-07009	CONTROLLER, SIZE 4 GEN 4.5 SEVCON	1
11	90-05179	HEXAGON SOCKET HEAD CAP SCREW ISO 4762 M8X60-8.8 ZM-F-01 REV 03	1
12	20-06699	HEATSINK #4 CONTROLLER SDS	1
13	90-03251	HEXAGON SOCKET HEAD CAP SCREW ISO 4762 M6X30-8.8 ZM-F-01	1
14	90-07268	HEXAGON SOCKET HEAD CAP SCREW ISO 4762 M8X25-10.9 ZM-F-01 REV 03 ZM-L-01 REV 01	1
15	45-08099	ELECTRICAL COMPONENT EVC135 CONTACTOR NOTE: Modular contactor	1
16	90-02101	WASHER ISO 7089 5-200HV ZM-F-01	1
17	90-07129	HEXAGON SOCKET BUTTON HEAD SCREW ISO 7380 M5X30-8.8 ZM-F-01 ZM-L-02	1
18	45-08058	JUNCTION POST SMALL TRIMMED	1
19	90-07125	HEXAGON SOCKET BUTTON HEAD SCREW ISO 7380 M5X10	1
20	45-05224	FUSE 300A 160VDC CLASS T	1
21	90-02100	WASHER ISO 7089 10-200 HV ZM-F-01	1
22	45-05240	FUSE NUT INTERNAL	1
23	PA-210	CONTACTOR COVER	1
24	PA-225	LV FUSE HOLDER	1
25	PA-226	BATTERY BOX SCREW	1
26	90-02054	PREVAILING TORQUE TYPE NUT DIN 985 M6-08 ZM-F-01	1
27	60-07190	DC-DC CONV 500W SEVCON 622-11211 ABS UNITS	1
28	26-08120	S ELECTRICAL PANEL	1
29	40-08080	MBB 11KW	1
29	40-08145	ASSY MBB POTTED GEN2 STEP E NOTE: Please provide VIN, Case or Claim Number when ordering to ensure proper programming. NOTE: Supersedes 40-08071.	1

30	90-02515	HEXAGON SOCKET HEAD CAP SCREW ISO 4762 M4X12-8.8 ZM-F-01 REV 03	1
31	90-02103	WASHER ISO 7089 6-200HV ZM-F-01	1
32	90-03236	PREVAILING TORQUE TYPE NUT DIN 985 M8-10 ZM-F-01	1
33	90-02098	HEXAGON SOCKET HEAD CAP SCREW ISO 4762 M8X40-8.8 ZM-F-01 REV 02	1
34	90-02104	WASHER ISO 7089 -8-200 HV ZM-F-01	1
35	90-02109	HEXAGON SOCKET BUTTON HEAD CAP SCREW ISO 7380 M5X12-8.8 ZM-F-01	1
36	45-08253	ONBOARD CHARGER 1300W NOTE: Current design includes additional ferrite. Please contact Zero Motorcycles Service Team if you need additional guidance on routing. NOTE: Supersedes 45-08123 and 45-08234.	1
37	46-08227	ASSEMBLY BATTERY MONOLITH ZF14.4 NOTE: Motorcycle VIN#, Case# or Claim# must be provided when ordering NOTE: 2014 - FOR INSTALLING IN 2014 MODELS, INCLUDE 12-08080 IN THE ORDER. IN CASE OF THE BIKE HAVING A POWER TANK, ALSO INCLUDE 12-08011 NOTE: 2013 -FOR INSTALLING IN 2013 MODELS, INCLUDE TO ORDER 12-08057	1
38	40-08069	BMS PCB ASSY LONG BRICK POTTED 17MY IMPL NOTE: PLEASE INCLUDE CASE#, VIN# OF BIKE AND BATTERY SERIAL # FOR PROGRAMMING PURPOSES	1
39	90-02102	WASHER ISO 7089 4-200HV ZM-F-01	1
40	90-07127	HEXAGON SOCKET HEAD CAP SCREW ISO 4762 M4X5-8.8 ZM-F-01 REV 03 ZM-L-02 REV 01	1
41	46-08097	MONOLITH BMS COVER	1
42	<i>Not Applicable to this Bike Model</i>		
43	80-08003	BATTERY FRONT UPPER FILLER PLUG	1
44	45-06774	DISC HORN K70/H12 V WITH BLACK ZINC	1
45	90-02104	WASHER ISO 7089 -8-200 HV ZM-F-01	1
46	90-02128	HEXAGON SOCKET BUTTON HEAD CAP SCREW ISO 7380 M8X20-8.8 ZM-F-01 REV 03	1
47	90-07265	HEXAGON SOCKET HEAD CAP SCREW ISO 4762 M6X20-8.8 ZM-F-01 REV 03 ZM-L-01 REV 01	1
48	90-02103	WASHER ISO 7089 6-200HV ZM-F-01	1
49	20-07073	SDS FRAME MOUNTED HORN BRACKET	1
50	90-02054	PREVAILING TORQUE TYPE NUT DIN 985 M6-08 ZM-F-01	1
51	90-02103	WASHER ISO 7089 6-200HV ZM-F-01	1
52	90-02104	WASHER ISO 7089 -8-200 HV ZM-F-01	1
53	90-03236	PREVAILING TORQUE TYPE NUT DIN 985 M8-10 ZM-F-01	1
54	90-07124	HEXAGON SOCKET BUTTON HEAD SCREW ISO 7380 M5X6-8.8	1

55	90-02937	M8X14MM BREAK AWAY HEX BOLT NOTE: One Time Use Bolt	1
56	45-02692	KEYSWITCH LOCK ZADI, IGNITION SWITCH NOTE: This part is the ignition switch and keys only. If you want a matching helmet lock for 16MY motorcycles and older, please order p/n 20-05202. If you want the key switch and a lock for a tank trunk, please order 27-08030. If you want a ignition and matching locks for tank trunk and storage trunks, please order part number 27-08044.	1
56	90-02054	PREVAILING TORQUE TYPE NUT DIN 985 M6-08 ZM-F-01	1
57	27-08030	KEYSWITCH AND 90 DEG TURN PANEL LATCH KEYED ALIKE SET	1
58	90-02103	WASHER ISO 7089 6-200HV ZM-F-01	1
59	40-08156	DASH LCD NOTE: Supersedes 40-08119	1
60	10-07504	12V ACCESSORY SOCKET KIT - SDS NOTE: Charge a GPS, smart phone or mp3 player using the Zero Motorcycles 12V Accessory Socket Kit. Designed to connect directly to your motorcycle(###)'s power port harness, the accessory socket enables you to charge small devices that have a cigarette lighter plug. The accessory outlet is rated up to 10 amps/120 watts. This kit includes all mounting hardware for installation on the 2014 and later Zero S, Zero DS and Zero SR motorcycles. NOTE: 2014 [Zero SR, Zero S, Zero DS] 2015 [Zero SR, Zero S, Zero DS] 2016-2018 [Zero SR, Zero S, Zero DS, Zero DSR]	1
61	20-07062	SDS TRIPLE CLAMP HARNESS SUPPORT	1
62	90-07124	HEXAGON SOCKET BUTTON HEAD SCREW ISO 7380 M5X6-8.8	1
63	90-07124	HEXAGON SOCKET BUTTON HEAD SCREW ISO 7380 M5X6-8.8	1
64	46-08045	BATTERY CASE CONT COVER FRONT 15MY IMPL	1

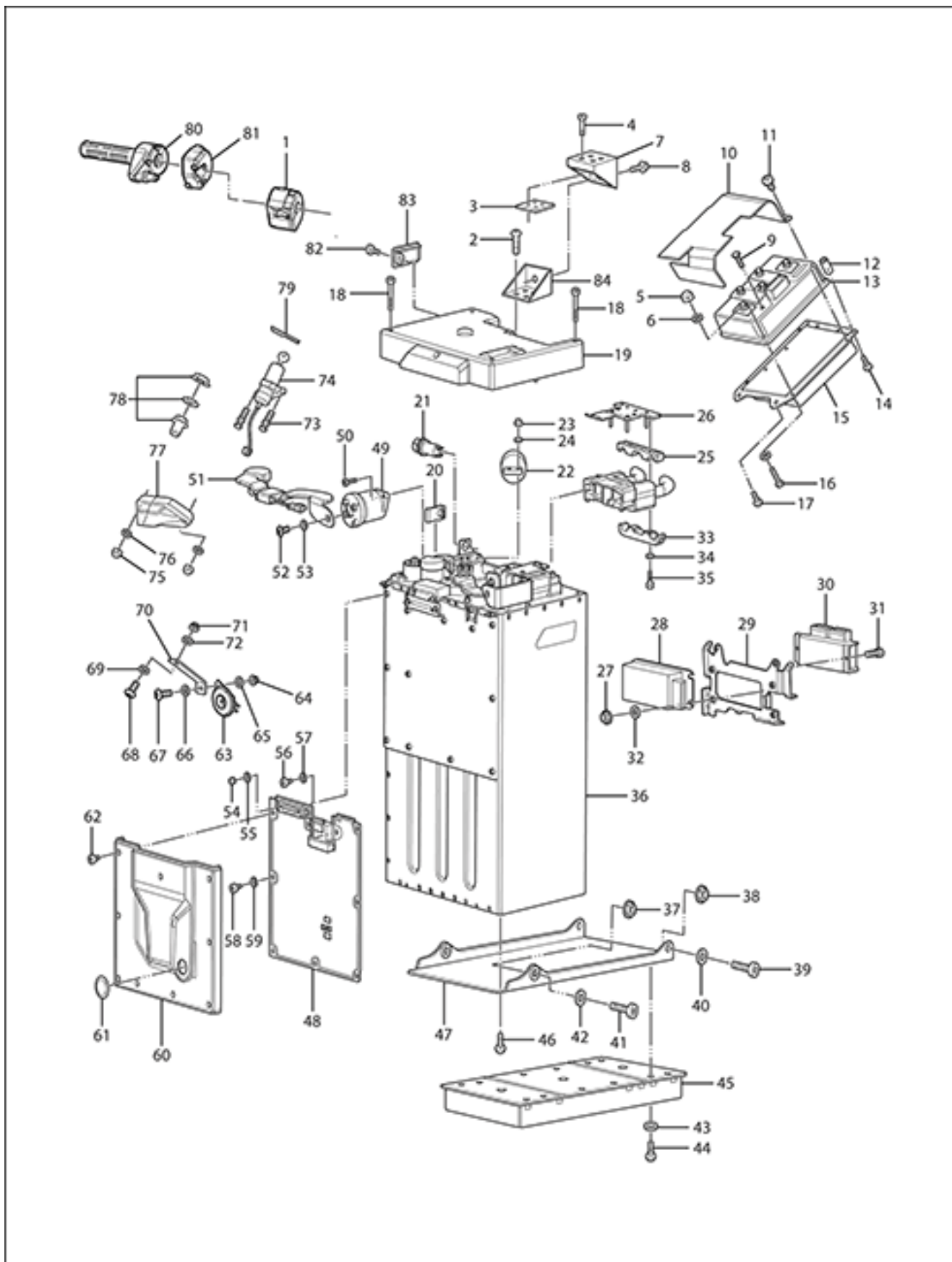

Callout	Part Number	Part Name	Qty. per Motorcycle
1	60-07780	LEFT HAND SWITCHGEAR ECIE	1
2	90-04083	HEXAGON SOCKET BUTTON HEAD CAP SCREW ISO 7380 M5X6-8.8 ZM-F-11 REV 03	1
3	26-08144	S LONGBRICK SUPPORT B	1
4	PA-233	BOLT	1
5	90-02071	HEXAGON NUT ISO 4032 M6-8 ZM-F-01 REV 02	1
6	90-02103	WASHER ISO 7089 6-200HV ZM-F-01	1
7	26-08119	S LONGBRICK SUPPORT A	1
8	90-07063	CONTROLLER LEAD BOLTS M8X16	1
9	90-07063	CONTROLLER LEAD BOLTS M8X16	1
10	20-05634	#4 CONTROLLER COVER	1
11	90-06250	CONTROLLER FORMEX PAN HEAD PHILLIPS #6 SHEET METAL SCREW	1
12	20-03823	SDS SEVCON CONTROLLER MOUNT REAR BOLT SPACERS	1
13	60-07009	CONTROLLER, SIZE 4 GEN 4.5 SEVCON	1
14	90-05179	HEXAGON SOCKET HEAD CAP SCREW ISO 4762 M8X60-8.8 ZM-F-01 REV 03	1
15	20-06699	HEATSINK #4 CONTROLLER SDS	1
16	90-03251	HEXAGON SOCKET HEAD CAP SCREW ISO 4762 M6X30-8.8 ZM-F-01	1
17	90-07268	HEXAGON SOCKET HEAD CAP SCREW ISO 4762 M8X25-10.9 ZM-F-01 REV 03 ZM-L-01 REV 01	1
18	90-08047	HEXAGON SOCKET HEAD CAP SCREW ISO 4762 M4X30-8.8 ZM-F-01 REV 03 ZM-L-02 REV 01	1
19	46-08065	LONGBRICK FUSE COVER MY17 IMPL	1
20	90-02140	CLIP-ON U-NUT M5X15.8DP	1
21	3101-012	BATTERY LOW VOLTAGE FUSE HOLDER	1
22	45-05224	FUSE 300A 160VDC CLASS T	1
23	90-02052	PREVAILING TORQUE TYPE NUT DIN 985 M4-08 ZM-F-01	1
24	90-02102	WASHER ISO 7089 4-200HV ZM-F-01	1
25	45-08008	CONNECTOR CONNECTOR STRAIN RELIEF CLAMP TOP 1/0 SB SMART	1
26	45-08110	CONNECTOR STRAIN RELIEF PLATE SB SMART LB	1
27	90-02054	PREVAILING TORQUE TYPE NUT DIN 985 M6-08 ZM-F-01	1
28	60-07190	DC-DC CONV 500W SEVCON 622-11211 ABS UNITS	1
29	26-08120	S ELECTRICAL PANEL	1
30	40-08080	MBB 11KW	1
30	40-08145	ASSY MBB POTTED GEN2 STEP E NOTE: Please provide VIN, Case or Claim Number when ordering to ensure proper programming. NOTE: Supersedes 40-08071.	1

31	90-02515	HEXAGON SOCKET HEAD CAP SCREW ISO 4762 M4X12-8.8 ZM-F-01 REV 03	1
32	90-02103	WASHER ISO 7089 6-200HV ZM-F-01	1
33	45-08007	CONNECTOR STRAIN RELIEF CLAMP BOTTOM 1/0 SB SMART	1
34	90-02480	WASHER ISO 7089 3-200HV ZM-F-01	1
35	90-08046	HEXAGON SOCKET HEAD CAP SCREW ISO 4762 M3X12-8.8 ZM-F-01 REV 03 ZM-L-02 REV 01	1
36	46-08214	ASSEMBLY BATTERY LONG CELL BOX ZF7.2 NOTE: Please supply VIN, Case or Claim Number when ordering.	1
37	90-03236	PREVAILING TORQUE TYPE NUT DIN 985 M8-10 ZM-F-01	1
38	90-03236	PREVAILING TORQUE TYPE NUT DIN 985 M8-10 ZM-F-01	1
39	90-07269	HEXAGON SOCKET HEAD CAP SCREW ISO 4762 M8X30-10.9 ZM-F-01 REV 03 ZM-L-01 REV 01	1
40	90-02104	WASHER ISO 7089 -8-200 HV ZM-F-01	1
41	90-07269	HEXAGON SOCKET HEAD CAP SCREW ISO 4762 M8X30-10.9 ZM-F-01 REV 03 ZM-L-01 REV 01	1
42	90-02104	WASHER ISO 7089 -8-200 HV ZM-F-01	1
43	90-02101	WASHER ISO 7089 5-200HV ZM-F-01	1
44	90-02109	HEXAGON SOCKET BUTTON HEAD CAP SCREW ISO 7380 M5X12-8.8 ZM-F-01	1
45	45-08253	ONBOARD CHARGER 1300W NOTE: Current design includes additional ferrite. Please contact Zero Motorcycles Service Team if you need additional guidance on routing. NOTE: Supersedes 45-08123 and 45-08234.	1
46	90-07130	HEXAGON SOCKET HEAD CAP SCREW ISO 4762 M4X10-8.8 ZM-F-01 REV 03 ZM-L-01 REV 01	1
47	46-08072	LONG BRICK LOWER MOUNT	1
48	40-08069	BMS PCB ASSY LONG BRICK POTTED 17MY IMPL NOTE: PLEASE INCLUDE CASE#, VIN# OF BIKE AND BATTERY SERIAL # FOR PROGRAMMING PURPOSES	1
49	45-08104	ELECTRICAL COMPONENT EVC135 CONTACTOR END MT NOTE: Longbrick	1
50	90-02512	HEXAGON SOCKET HEAD CAP SCREW ISO 4762 M4X16-8.8 ZM-F-01	1
51	46-08104	CURRENT SENSOR BUS BAR ASSEMBLY LONGBRICK	1
52	90-07125	HEXAGON SOCKET BUTTON HEAD SCREW ISO 7380 M5X10	1
53	90-02101	WASHER ISO 7089 5-200HV ZM-F-01	1
54	90-02052	PREVAILING TORQUE TYPE NUT DIN 985 M4-08 ZM-F-01	1
55	90-02102	WASHER ISO 7089 4-200HV ZM-F-01	1
56	90-07127	HEXAGON SOCKET HEAD CAP SCREW ISO 4762 M4X5-8.8 ZM-F-01 REV 03 ZM-L-02 REV 01	1
57	90-07389	TOOTHED LOCK WASHER WITH EXTERNAL TEETH DIN 6797 A M5 ZM-F-01	1

58	90-07126	HEXAGON SOCKET HEAD CAP SCREW ISO 4762 M4X8-8.8 ZM-F-01 REV 03 ZM-L-02 REV 01	1
59	90-02102	WASHER ISO 7089 4-200HV ZM-F-01	1
60	46-08096	LONGBRICK BMS COVER	1
61	80-08003	BATTERY FRONT UPPER FILLER PLUG	1
62	90-07126	HEXAGON SOCKET HEAD CAP SCREW ISO 4762 M4X8-8.8 ZM-F-01 REV 03 ZM-L-02 REV 01	1
63	45-06774	DISC HORN K70/H12 V WITH BLACK ZINC	1
64	90-03236	PREVAILING TORQUE TYPE NUT DIN 985 M8-10 ZM-F-01	1
65	90-02104	WASHER ISO 7089 -8-200 HV ZM-F-01	1
66	90-02104	WASHER ISO 7089 -8-200 HV ZM-F-01	1
67	90-02128	HEXAGON SOCKET BUTTON HEAD CAP SCREW ISO 7380 M8X20-8.8 ZM-F-01 REV 03	1
68	90-07265	HEXAGON SOCKET HEAD CAP SCREW ISO 4762 M6X20-8.8 ZM-F-01 REV 03 ZM-L-01 REV 01	1
69	90-02103	WASHER ISO 7089 6-200HV ZM-F-01	1
70	20-07073	SDS FRAME MOUNTED HORN BRACKET	1
71	90-02054	PREVAILING TORQUE TYPE NUT DIN 985 M6-08 ZM-F-01	1
72	90-02103	WASHER ISO 7089 6-200HV ZM-F-01	1
73	90-02937	M8X14MM BREAK AWAY HEX BOLT NOTE: One Time Use Bolt	1
74	45-02692	KEYSWITCH LOCK ZADI, IGNITION SWITCH NOTE: This part is the ignition switch and keys only. If you want a matching helmet lock for 16MY motorcycles and older, please order p/n 20-05202. If you want the key switch and a lock for a tank trunk, please order 27-08030. If you want a ignition and matching locks for tank trunk and storage trunks, please order part number 27-08044.	1
74	27-08030	KEYSWITCH AND 90 DEG TURN PANEL LATCH KEYED ALIKE SET	1
74	27-08044	KEYSWITCH AND TWO 90 DEG TURN PANEL LATCH KEYED ALIKE SET	1
75	90-02054	PREVAILING TORQUE TYPE NUT DIN 985 M6-08 ZM-F-01	1
76	90-02103	WASHER ISO 7089 6-200HV ZM-F-01	1
77	40-08156	DASH LCD NOTE: Supersedes 40-08119	1
		12V ACCESSORY SOCKET KIT - SDS NOTE: Charge a GPS, smart phone or mp3 player using the Zero Motorcycles 12V Accessory Socket Kit. Designed to connect directly to your motorcycle{###}'s power port harness, the accessory socket enables you to charge small devices that have a cigarette lighter plug. The accessory outlet is rated up to 10 amps/120 watts. This kit includes all mounting hardware for installation on the 2014 and later Zero S, Zero DS and Zero SR motorcycles. NOTE: 2014 [Zero SR, Zero S, Zero DS] 2015 [Zero SR, Zero S,	

78	10-07504	Zero DS] 2016-2018 [Zero SR, Zero S, Zero DS, Zero DSR]	1
79	20-07062	SDS TRIPLE CLAMP HARNESS SUPPORT	1
80	45-08039	THROTTLE BITRON HALL EFFECT PCB NOTE: Supersedes 27-08000	1
81	40-06054	KILL MODE START SWITCH	1
82	90-07288	HEXAGON SOCKET HEAD CAP SCREW ISO 4762 M5X12-8.8 ZM-F-01 REV 03 ZM-L-01 REV 01	1
83	46-08091	BATTERY LOW VOLTAGE FUSE COVER	1
84	26-08145	S LONGBRICK SUPPORT C	1