

**Zero Motocycles**  
**SR 2016 Exploded Views**

ZEV0021 - Lighting

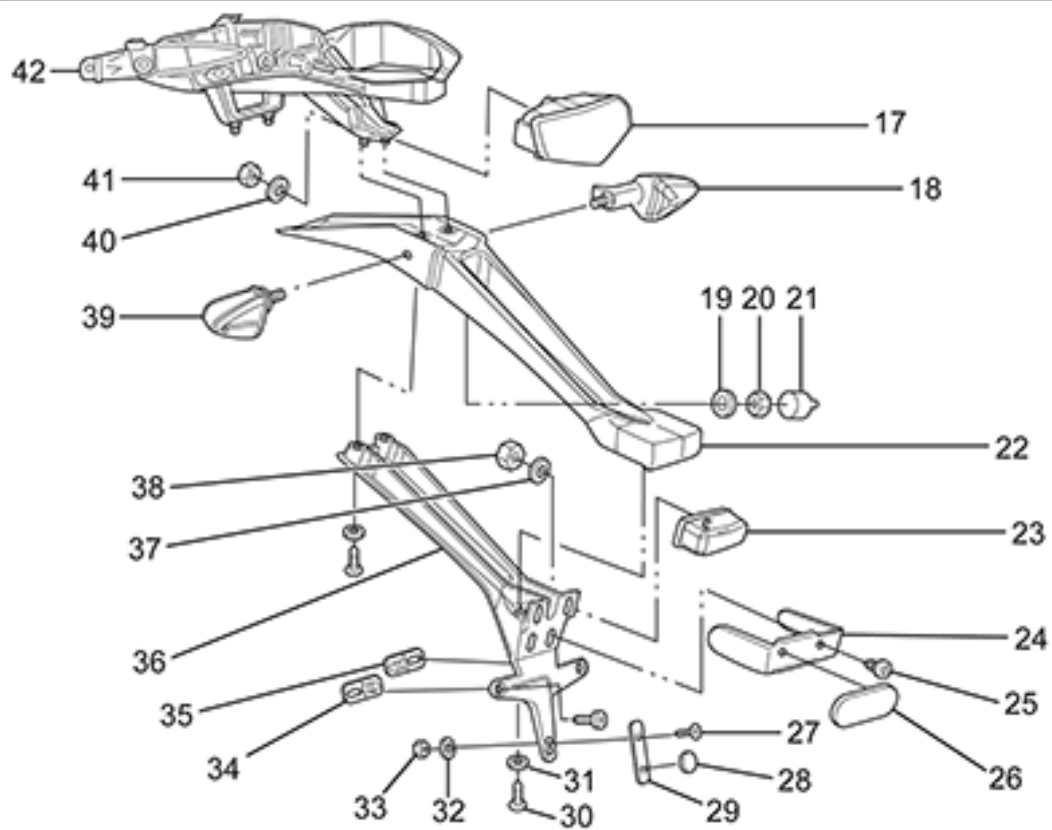
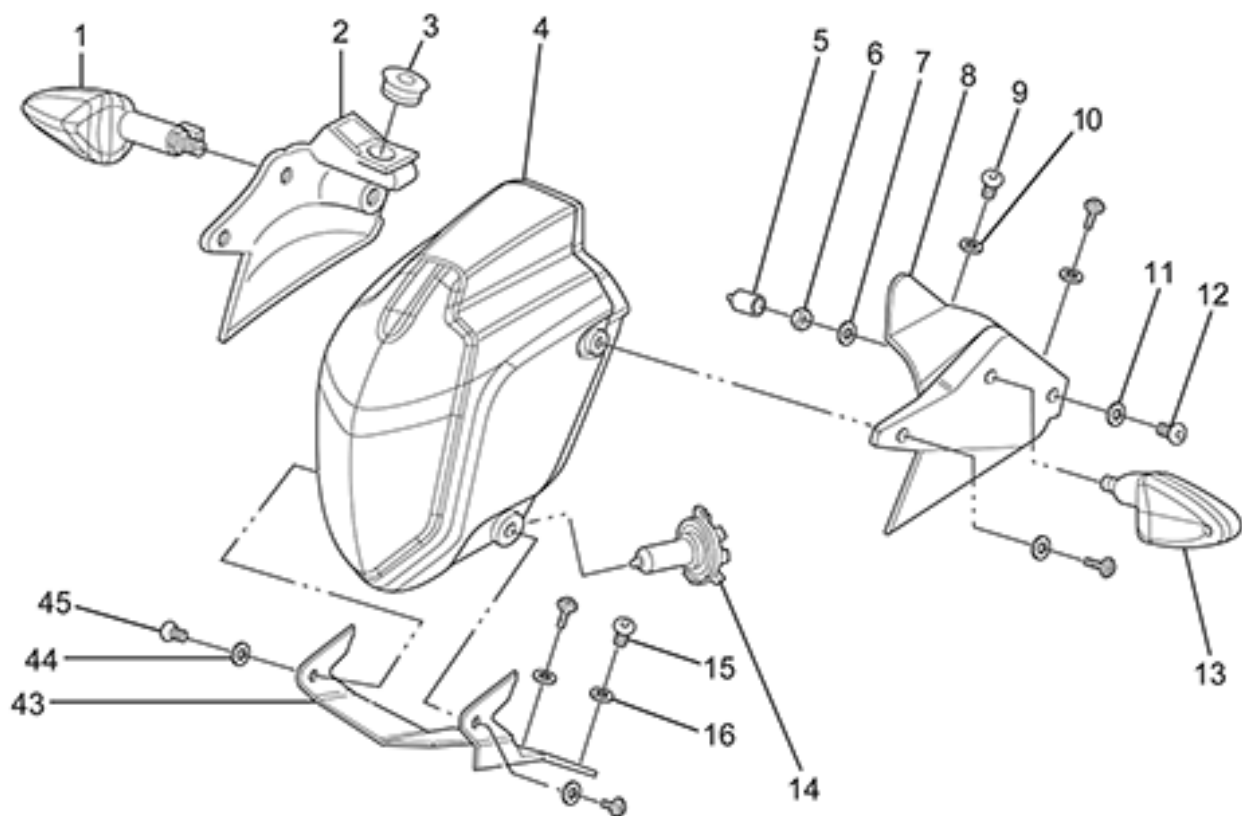

ZEV0021 - Lighting

Callout	Part Number	Part Name	Qty. per Motorcycle
1	65-03462	TURN SIGNAL FR-RH RR-LH	1
2	24-08091	HEADLIGHT MOUNT RIGHT FOR ABS	1
3	27-08034	12V ACCESSORY COVER, SMALL	1
4	45-03679	HEADLIGHT ASSY, 60/55W, TRIOM	1
5	20-03146	TURN SIGNAL HEX NUT CAP	2
6	90-02072	HEXAGON THIN NUT DIN 439-B M10 1.5-04 ZM-F-01	2
7	90-02043	TOOTHED LOCK WASHER WITH EXTERNAL TEETH DIN 6797 A M10-B85 ZM-F-01	2
8	24-08092	HEADLIGHT MOUNT LEFT FOR ABS	1
9	90-04084	HEXAGON SOCKET BUTTON HEAD CAP SCREW ISO 7380 M5X16-8.8 ZM-F-11 REV 03	4
10	90-04085	WASHER M5 X 11 X 1 NYLON 6/6 BLACK	4
11	90-04085	WASHER M5 X 11 X 1 NYLON 6/6 BLACK	4
12	90-04084	HEXAGON SOCKET BUTTON HEAD CAP SCREW ISO 7380 M5X16-8.8 ZM-F-11 REV 03	4
13	65-03463	TURN SIGNAL FR-LH RR-RH	1
14	65-08002	SDS HEADLIGHT BULB	1
15	90-07281	HEXAGON SOCKET BUTTON HEAD SCREWS ISO 7380 M6X12-8.8 ZM-F-01 REV 03 ZM-L-01 REV 01	2
16	90-02101	WASHER ISO 7089 5-200HV ZM-F-01	4
17	65-04459	LED TAIL LIGHT TRIOM	1
18	65-03463	TURN SIGNAL FR-LH RR-RH	1
19	90-02043	TOOTHED LOCK WASHER WITH EXTERNAL TEETH DIN 6797 A M10-B85 ZM-F-01	2
20	90-02072	HEXAGON THIN NUT DIN 439-B M10 1.5-04 ZM-F-01	2
21	20-03146	TURN SIGNAL HEX NUT CAP	2
22	24-04439	SDS TAIL POD TOP NOTE: Top half only. Order bottom half PN: 24-05158	1
23	65-04460	LICENSE PLATE LIGHT	1
24	24-05159	REFLECTOR MOUNT BRACKET	1
25	90-05885	PHILIPS HEAD SHEET METAL SCREW 6 X 1/2	10
26	20-03487	REFLECTOR, OVAL, ADH BACK, RED ECIE	1
27	90-05244	HEXAGON SOCKET COUNTERSUNK HEAD SCREW ISO 10642 M5X12-10.9 ZM-F-01 REV 03	4
28	20-05241	LICENSE PLATE BUMPER	1
29	24-05292	LICENSE PLATE BRACKET EXTENSION LOWER NOTE: ONLY USED IN EU/AUS REGION	1
30	90-07281	HEXAGON SOCKET BUTTON HEAD SCREWS ISO 7380 M6X12-8.8 ZM-F-01 REV 03 ZM-L-01 REV 01	2
31	90-02103	WASHER ISO 7089 6-200HV ZM-F-01	10

32	90-04085	WASHER M5 X 11 X 1 NYLON 6/6 BLACK	4
33	90-02053	PREVAILING TORQUE TYPE NUT DIN 985 M5-08 ZM-F-01 REV 02	8
34	24-05161	LICENSE PLATE BRACKET EXTENSIONS NOTE: ONLY USED IN EU/AUS REGIONS	2
35	24-05161	LICENSE PLATE BRACKET EXTENSIONS NOTE: ONLY USED IN EU/AUS REGIONS	2
36	24-05158	SDS TAIL POD BOTTOM NOTE: Bottom half only. Order top half PN: 24-04439	1
37	90-07389	TOOTHED LOCK WASHER WITH EXTERNAL TEETH DIN 6797 A M5 ZM-F-01	4
38	90-02053	PREVAILING TORQUE TYPE NUT DIN 985 M5-08 ZM-F-01 REV 02	8
39	65-03462	TURN SIGNAL FR-RH RR-LH	1
40	90-02103	WASHER ISO 7089 6-200HV ZM-F-01	10
41	90-02054	PREVAILING TORQUE TYPE NUT DIN 985 M6-08 ZM-F-01	4
42	20-05883-1	SR TAIL FRAME	1
43	20-05910	HEADLIGHT BRACKET	1
44	90-02101	WASHER ISO 7089 5-200HV ZM-F-01	4
45	90-02545-1	BOLT M6 X 8	1



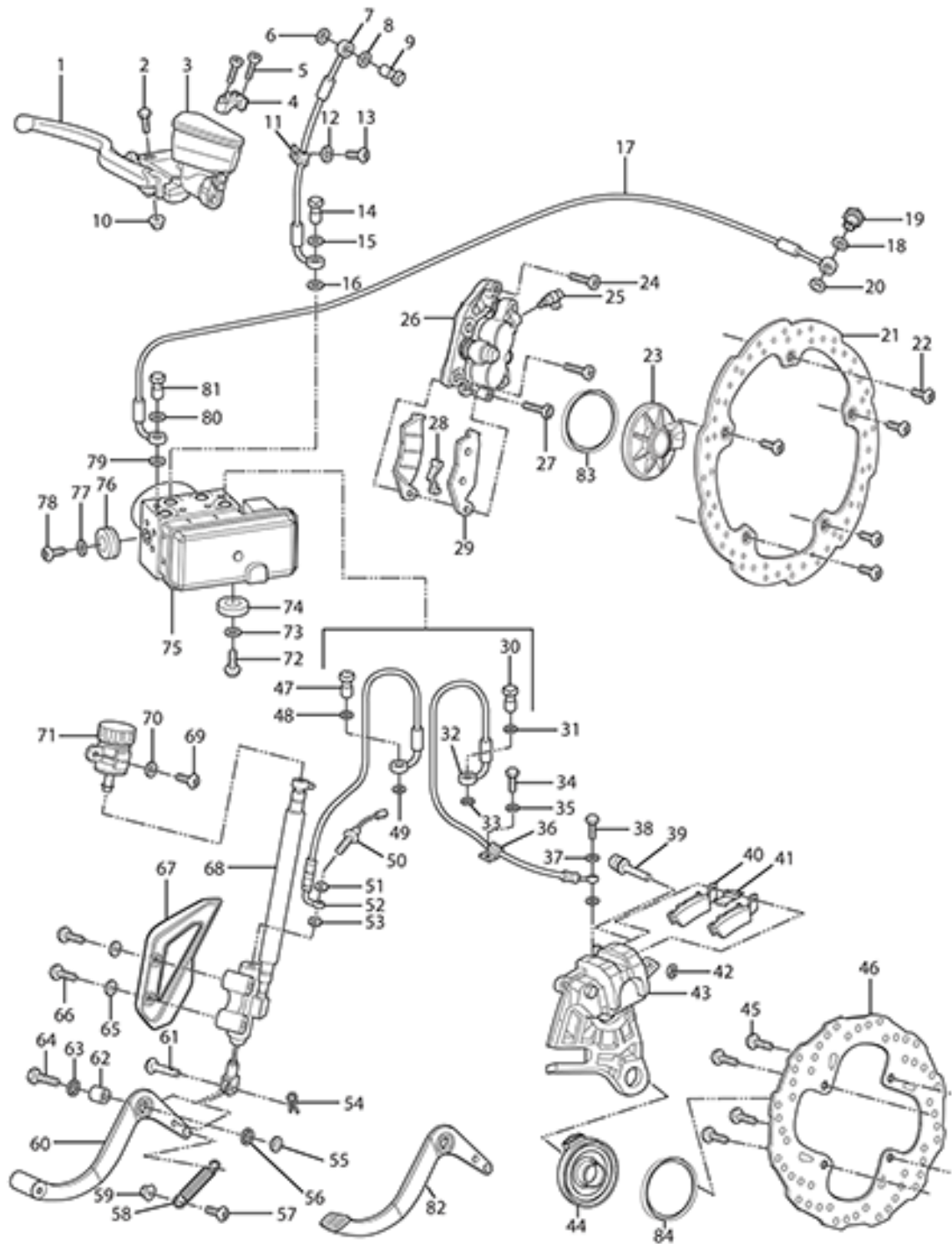

## ZEV0022 - Braking

Callout	Part Number	Part Name	Qty. per Motorcycle
1	25-08032	SDS BRAKE JJUAN LEVER NOTE: Superseded by 25-08199	1
2	PA-177	BRAKE LEVER PIVOT BOLT	1
3	25-07682	JJUAN 12.7MM FRONT MASTER CYLINDER SDS/FXS	1
4	25-08064	FRONT MASTER CYLINDER CLAMP KIT NOTE: SDS/XMX NOTE: Mount and Bolts NOTE: Upper Mirror Mount RH	1
5	PA-178	MIRROR POST BOLT 6M X 20	1
6	PA-128	BANJO GASKET	1
7	25-07824	SDS FRONT BRAKE LINE MC TO HCU	1
8	PA-128	BANJO GASKET	1
9	90-08014-3	BANJO BOLT	1
10	PA-130	BRAKE LEVER PIVOT BOLT NUT	1
11	20-01758	LOOP CLAMP NYLON 3/4" BLK	1
12	PA-223	FLAT WASHER	1
13	PA-224	BOLT	1
14	PA-180	BANJO BOLT	1
15	PA-128	BANJO GASKET	1
16	PA-128	BANJO GASKET	1
17	25-07825	S FRONT BRAKE LINE HCU TO CALIPER	1
18	PA-128	BANJO GASKET	1
19	PA-181	BANJO BOLT	1
20	PA-128	BANJO GASKET	1
21	25-07702	BRAKE ROTOR 320MM FIXED NOTE: REPLACED BY 25-08169	1
22	90-07833	CUSTOM ROTOR BOLT M8X23MM SHOULDER SCREW	1
23	45-07496	MPI WHEEL SPEED SENSOR	1
24	90-08029	HEXAGON HEAD SCREW ISO 4762 M10-1.25X40-10.9 ZM-F-01 REV03 ZM-L-01 REV01	1
25	PA-182	BLEEDER VALVE	1
26	25-07686	JJUAN 32/30MM FRONT CALIPER SDS	1
27	90-08029	HEXAGON HEAD SCREW ISO 4762 M10-1.25X40-10.9 ZM-F-01 REV03 ZM-L-01 REV01	1
28	PA-183	ANTI RATTLE CLIP	1
29	25-08029	BRAKE PADS SET FRONT SDS	1
30	PA-185	BANJO BOLT	1
31	PA-128	BANJO GASKET	1
32	25-08093	SDS REAR BRAKE LINE HCU TO CALIPER NOTE: Supersedes part number 25-07821.	1

33	PA-128	BANJO GASKET	1
34	90-07292	HEXAGON SOCKET BUTTON HEAD CAP SCREW ISO 7380 M5X16-8.8 ZM-F-11 REV 01 ZM-L-01 REV 01 NOTE: Does not apply to DS	1
35	90-02105	WASHER ISO 7093-1 6-200 HV ZM-F-01	1
36	20-01758-1	BRAKE LINE GUIDE	1
37	PA-128	BANJO GASKET	1
38	PA-186	BANJO BOLT AT REAR CALIPER	1
39	PA-187	CALIPER SLIDE BOLT	1
40	25-08030	BRAKE PAD SET SDS REAR	1
41	PA-189	ANTI RATTLE CLIP	1
42	PA-190	CALIPER SLIDE BOLT CLIP	1
43	25-08099	JJUAN 34MM REAR CALIPER NOTE: Old Part P/N: 25-08083	1
44	45-07496	MPI WHEEL SPEED SENSOR	1
45	90-07516	REAR BRAKE ROTOR BOLT NOTE: Supersedes 90-08015.	1
46	25-08170	BRAKE ROTOR 240MM REAR	1
47	PA-191	BANJO BOLT AT HCU	1
48	PA-128	BANJO GASKET	1
49	PA-128	BANJO GASKET	1
50	PA-192	BRAKE LIGHT SWITCH NOTE: Not sold separately. Please order the Master Cylinder.	1
51	PA-128	BANJO GASKET	1
52	25-07820	SDS REAR BRAKE LINE MC TO HCU	1
53	PA-128	BANJO GASKET	1
54	90-02133	1/4 X 3/4 CLEVIS PIN STEEL ZINC	1
55	90-02100	WASHER ISO 7089 10-200 HV ZM-F-01	1
56	20-02465	IGLIDE BEARING GFM-1416-06	1
57	90-02124-1	BUTTON CAP SCREW M6 X 25	1
58	25-08070	BRAKE PEDAL SPRING	1
59	20-02465	IGLIDE BEARING GFM-1416-06	1
60	25-08073	BRAKE PEDAL STREET PEG	1
61	90-02133	1/4 X 3/4 CLEVIS PIN STEEL ZINC	1
62	20-02455	X BRAKE PEDAL SPACER	1
63	20-02465	IGLIDE BEARING GFM-1416-06	1
64	90-07318	HEXAGON FLANGE BOLT DIN 6921 M10X35 10.9 ZM-F-01 REV 03 ZM-L-01 REV 01	1
65	90-02103	WASHER ISO 7089 6-200HV ZM-F-01	1
66	90-07323	HEXAGON SOCKET BUTTON HEAD CAP SCREW ISO 7380 M6X25-8.8 ZM-F-01 REV 03 ZM-L-01 REV 01	1
67	25-07457	MASTER CYLINDER GUARD FOR J-JUAN MASTER CYLINDER	1
68	25-08015	JJUAN 12MM REAR MASTER CYLINDER SDS	1
69	90-07273	HEXAGON SOCKET BUTTON HEAD CAP SCREW ISO 7380 M6X16-8.8 ZM-F-01 REV 03 ZM-L-01 REV 01	1



70	PA-196	WASHER	1
71	PA-197	REAR MASTER CYLINDER RESERVOIR	1
72	90-07273	HEXAGON SOCKET BUTTON HEAD CAP SCREW ISO 7380 M6X16-8.8 ZM-F-01 REV 03 ZM-L-01 REV 01	1
73	90-02105	WASHER ISO 7093-1 6-200 HV ZM-F-01	1
74	90-08027	GROMMET VIBRATION ISOLATION M6	1
75	25-08092	BOSCH ABS HCU FLUID FILLED 6 PROFILE VARIANTS NOTE: Supersedes part number 25-08081 and 25-08082.	1
76	90-08027	GROMMET VIBRATION ISOLATION M6	1
77	90-02105	WASHER ISO 7093-1 6-200 HV ZM-F-01	0
78	90-07273	HEXAGON SOCKET BUTTON HEAD CAP SCREW ISO 7380 M6X16-8.8 ZM-F-01 REV 03 ZM-L-01 REV 01	1
79	PA-128	BANJO GASKET	1
80	PA-128	BANJO GASKET	1
81	PA-185	BANJO BOLT	1
82	<i>Not Applicable to this Bike Model</i>		
83	25-08080	ABS MAGNET RING	1
84	25-08080	ABS MAGNET RING	1

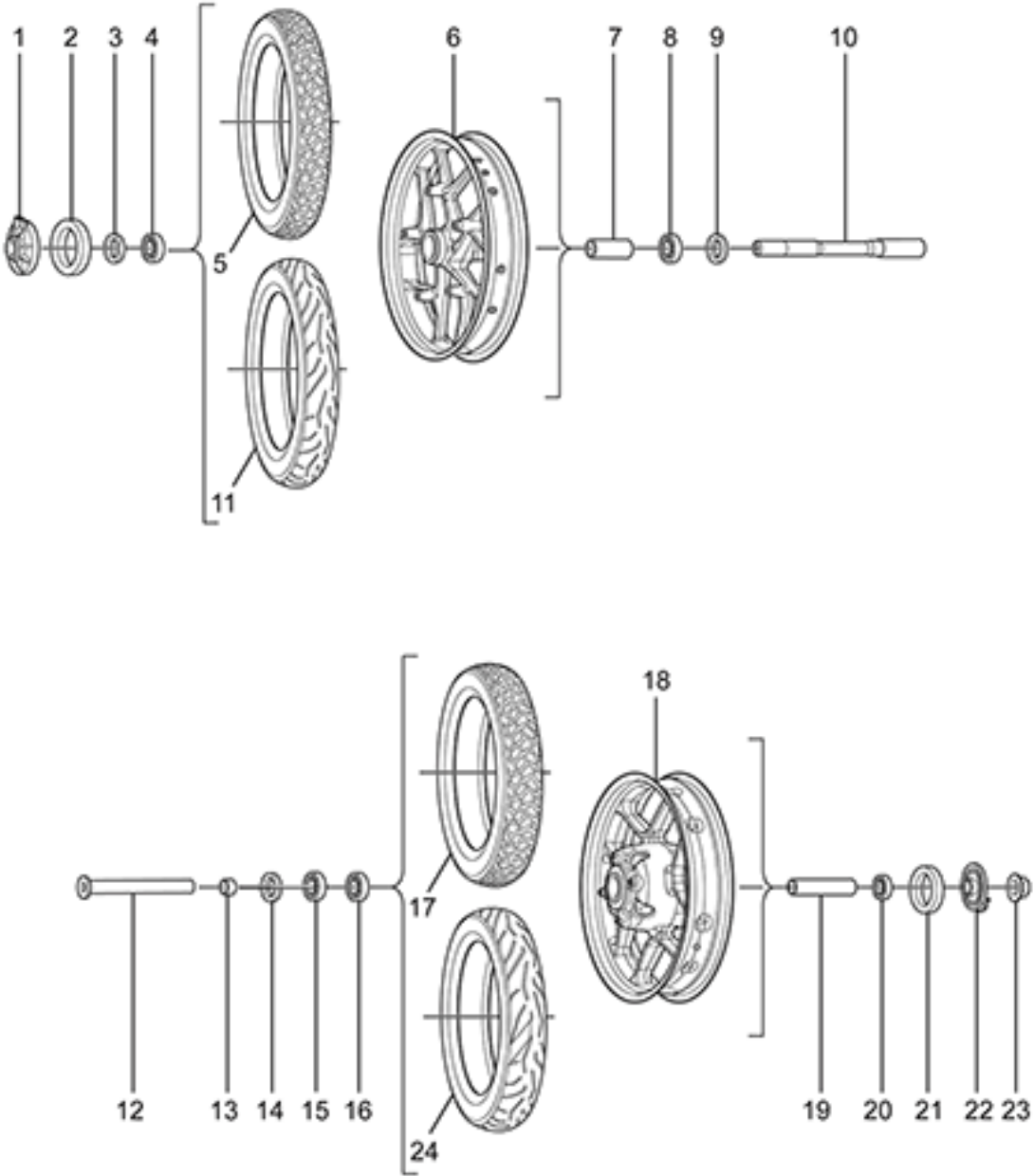

## ZEV0023 - Wheel Assy

Callout	Part Number	Part Name	Qty. per Motorcycle
1	45-07496	MPI WHEEL SPEED SENSOR	1
2	25-08080	ABS MAGNET RING	1
3	23-07774	6204 BEARING DUST SEAL	2
4	20-06138	BEARING 6204 NOTE: Bearing used as swing arm bearing in some models and as the wheel bearing (qty of 5; 2 in front and three in rear wheel) in 2015 and later models. NOTE: Manufacturer part number is 6204-2RS	2
5	<i>Not Applicable to this Bike Model</i>		
6	23-08065-4	3.00X17 FRONT CAST WHEEL ASSY SILVER BLACK	1
7	23-07775	FRONT WHEEL BEARING TUBE	1
8	20-06138	BEARING 6204 NOTE: Bearing used as swing arm bearing in some models and as the wheel bearing (qty of 5; 2 in front and three in rear wheel) in 2015 and later models. NOTE: Manufacturer part number is 6204-2RS	2
9	23-07774	6204 BEARING DUST SEAL	2
10	23-07491	HOLLOW AXLE FRONT	1
11	23-07668	PIRELLI DIABLO ROSSO II, 110/70R17 M/C 54H	1
12	23-08032	REAR AXLE 20MM HOLLOW, ROUNDED END	1
13	23-07489	WHEEL SPACER DRIVE SIDE REAR	1
14	23-07774	6204 BEARING DUST SEAL	2
15	20-06138	BEARING 6204 NOTE: Bearing used as swing arm bearing in some models and as the wheel bearing (qty of 5; 2 in front and three in rear wheel) in 2015 and later models. NOTE: Manufacturer part number is 6204-2RS	2
16	20-06138	BEARING 6204 NOTE: Bearing used as swing arm bearing in some models and as the wheel bearing (qty of 5; 2 in front and three in rear wheel) in 2015 and later models. NOTE: Manufacturer part number is 6204-2RS	2
17	<i>Not Applicable to this Bike Model</i>		
18	23-08056-4	WHEEL 3.50X17 SDS REAR CAST WHEEL ASSY 16MY IMPL BLACK-SILVER C	1
19	23-07776	REAR WHEEL BEARING TUBE 15MY	1
20	20-06138	BEARING 6204 NOTE: Bearing used as swing arm bearing in some models and as the wheel bearing (qty of 5; 2 in front and three in rear wheel) in 2015 and later models. NOTE: Manufacturer part number is 6204-2RS	2

21	25-08080	ABS MAGNET RING	1
22	45-07496	MPI WHEEL SPEED SENSOR	1
23	90-05678	U-NUT M20X1.5 FLANGE 27S 15H NOTE: Rear Axle Nut	1
24	23-07669	PIRELLI DIABLO ROSSO II, 140/70R17 M/C 66H	1



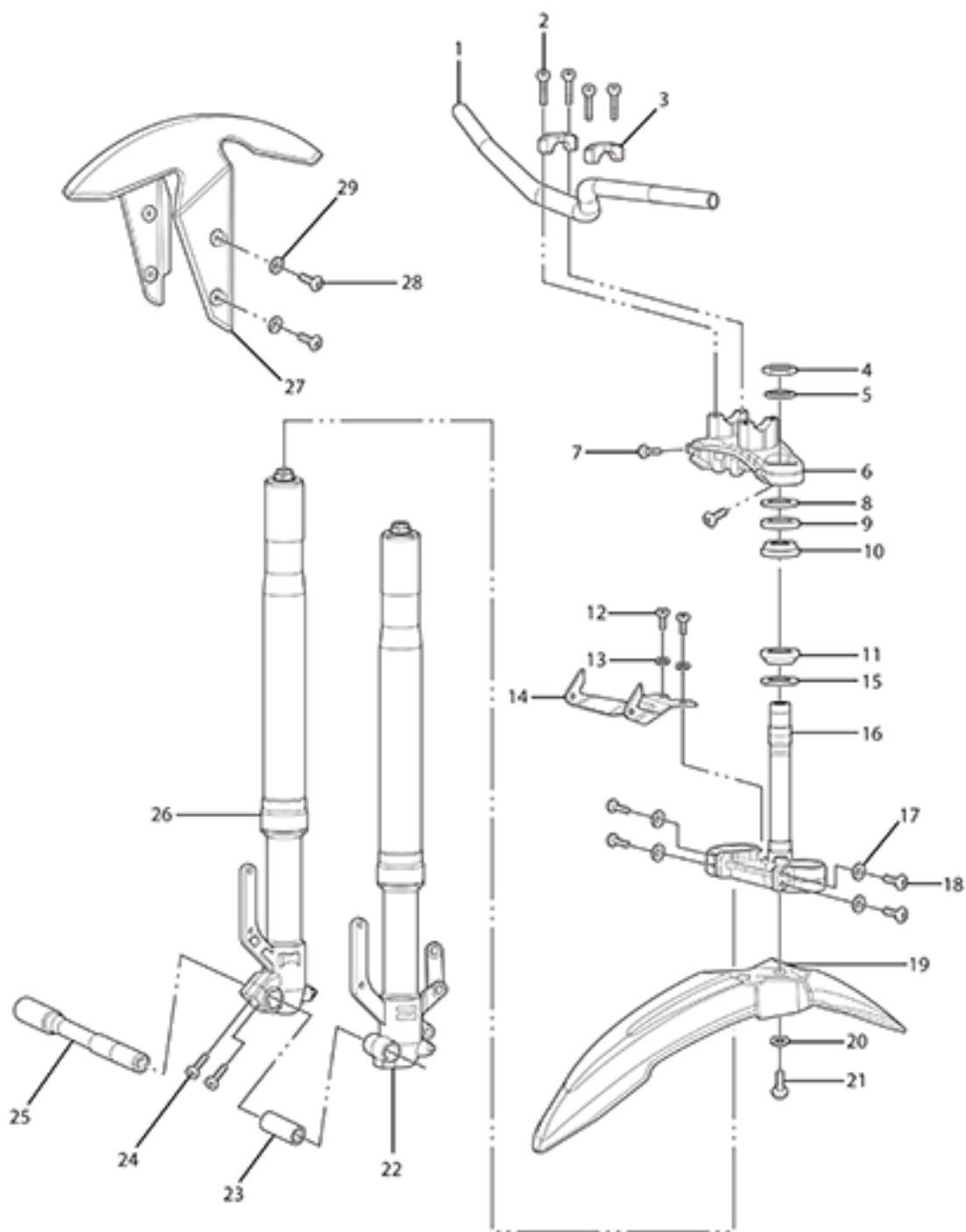

ZEV0024 - Steering Systems

Callout	Part Number	Part Name	Qty. per Motorcycle
1	27-08150	SPORT HANDLEBAR NO LOGO NOTE: Supersedes part number 27-08049.	1
2	90-02096	MOTOR MOUNTING LEFT FRONT TOP AND LEFT FRONT BOTTOM BOLT	1
3	22-00687	S HANDLEBAR CLAMP	1
4	22-06279	STEERING STEM THIN NUT M27 X 1.5 X 8MM	1
5	20-06278	WASHER 41 - 27.5 X 2 MM	1
6	22-07622	SDS UPPER TRIPLE CLAMP 15MY IMP	1
7	90-02094	HEXAGON SOCKET HEAD CAP SCREW ISO 4762 M8X25-10.9 ZM-F-01 REV 03	1
8	22-06257	STEERING STEM LOCK NUT M 30 X1.5 MM	1
9	81-08045	BEARING LIP SEAL OVERMOLDED 55MM OD NOTE: Supersedes part 20-06113	1
10	20-06068	STEERING HEAD BEARING KOYO SAC3055-1	1
11	20-06068	STEERING HEAD BEARING KOYO SAC3055-1	1
12	90-02109	HEXAGON SOCKET BUTTON HEAD CAP SCREW ISO 7380 M5X12-8.8 ZM-F-01	1
13	90-02101	WASHER ISO 7089 5-200HV ZM-F-01	1
14	20-05910	HEADLIGHT BRACKET	1
15	81-08045	BEARING LIP SEAL OVERMOLDED 55MM OD NOTE: Supersedes part 20-06113	1
16	22-08092	SDS LOWER TRIPLE CLAMP ASSY NOTE: REPLACES 25-08082	1
17	90-02104	WASHER ISO 7089 -8-200 HV ZM-F-01	1
18	90-02094	HEXAGON SOCKET HEAD CAP SCREW ISO 4762 M8X25-10.9 ZM-F-01 REV 03	1
19	<i>Not Applicable to this Bike Model</i>		
20	<i>Not Applicable to this Bike Model</i>		
21	<i>Not Applicable to this Bike Model</i>		
22	22-08046	S FORK 41MM LEFT NOTE: Please provide last five digits of VIN NOTE: NOTE: 2015-2016 [Zero S and Zero SR] please confirm matching set, 22-08047 (S FORK 41MM RIGHT) and 22-08046 (S FORK 41MM LEFT).	1
23	PA-200	INNER BEARING SPACER	1
24	PA-205	M8 X 30 BOLT	1
25	23-07491	HOLLOW AXLE FRONT	1
26	22-08047	S FORK 41MM RIGHT NOTE: Please provide last five digits of VIN NOTE: NOTE: 2015-2016 [Zero S and Zero SR] please confirm matching set, 22-08047 (S FORK 41MM RIGHT) and 22-08046 (S FORK 41MM LEFT).	1

27	24-08027-6	FRONT FENDER STREET TO WORK WITH SHOWA SUSPENSION RED	1
28	90-07292	HEXAGON SOCKET BUTTON HEAD CAP SCREW ISO 7380 M5X16-8.8 ZM-F-11 REV 01 ZM-L-01 REV 01 NOTE: Does not apply to DS	1
29	90-04085	WASHER M5 X 11 X 1 NYLON 6/6 BLACK	1





ZEV0025 - Body Trim

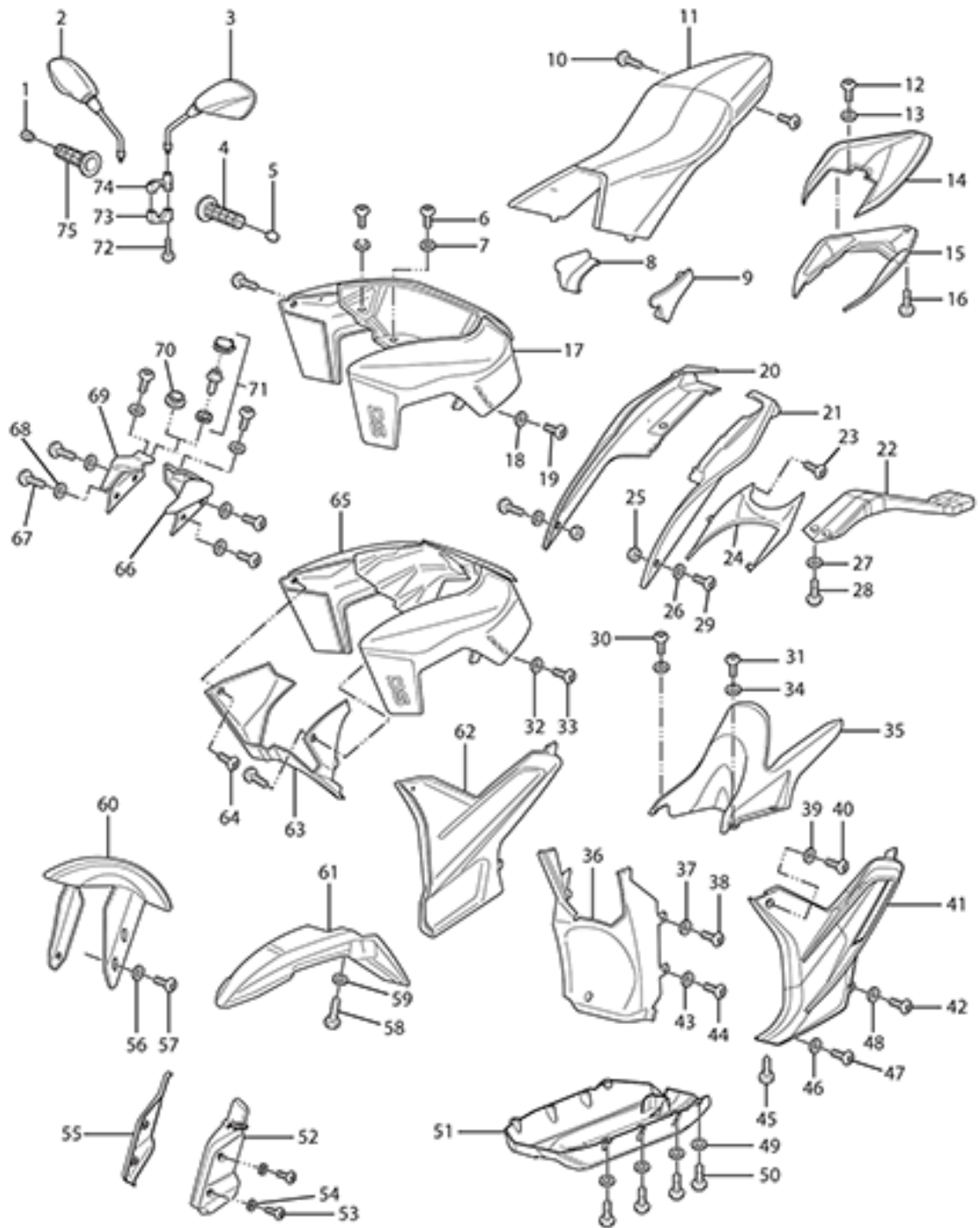

## ZEV0025 - Body Trim

Callout	Part Number	Part Name	Qty. per Motorcycle
1	27-08002	HANDLEBAR END CAP	1
2	27-08057	MIRROR RH	1
3	27-08056	MIRROR LH	1
4	27-08083	HAND GRIP NON-THROTTLE SIDE NOTE: Grip does not have Zero logo. Order with 27-08082 if you want a matching pair. NOTE: Supersedes p/n 27-08007.	1
5	27-08002	HANDLEBAR END CAP	1
6	90-04084	HEXAGON SOCKET BUTTON HEAD CAP SCREW ISO 7380 M5X16-8.8 ZM-F-11 REV 03	1
7	90-04085	WASHER M5 X 11 X 1 NYLON 6/6 BLACK	1
8	24-08132	SEAT GAP FILLER RIGHT	1
9	24-08133	SEAT GAP FILLER LEFT	1
10	90-08005	SEAT BOLT M8X55 NOTE: Supersedes 90-07009.	1
11	27-08025	SDS SEAT ASSEMBLY MY15 NOTE: replaces 24-04854	1
12	PA-41	BOLT	1
13	PA-42	WASHER	1
14	24-04432-6	SDS TAIL TOP RED	1
14	24-04439	SDS TAIL POD TOP NOTE: Top half only. Order bottom half PN: 24-05158	1
15	24-04433-6	SDS TAIL BOTTOM RED	1
16	90-05885	PHILIPS HEAD SHEET METAL SCREW 6 X 1/2	1
17	24-08206-1	Option #1: BLACK NOTE: Plastic tank assembly used with the Zero SR includes Zero logo and SR letters. Includes cut out area for tank bag. NOTE: Supersedes 24-08074	1
	24-08206-4	Option #2: WHITE NOTE: Plastic tank assembly used with the Zero SR includes Zero logo and SR letters. Includes cut out area for tank bag. NOTE: Supersedes 24-08074	1
18	90-04085	WASHER M5 X 11 X 1 NYLON 6/6 BLACK	1
19	90-04084	HEXAGON SOCKET BUTTON HEAD CAP SCREW ISO 7380 M5X16-8.8 ZM-F-11 REV 03	1
20	24-08080	TRUNK PAN RIGHT COMPRESSION ADJUSTER TRIMMED SR	1
21	24-05889	TRUNK PAN LEFT FOR SIZE 6 CONTROLLER	1
22	24-04439	SDS TAIL POD TOP NOTE: Top half only. Order bottom half PN: 24-05158	1
23	20-03066	RIVET PUSH PUSH NYLON M6	1

24	24-07593	SIZE 6 CONTROLLER FILLER	1
25	PA-43	NUT	1
26	PA-44	WASHER	1
27	90-02103	WASHER ISO 7089 6-200HV ZM-F-01	1
28	90-07281	HEXAGON SOCKET BUTTON HEAD SCREWS ISO 7380 M6X12-8.8 ZM-F-01 REV 03 ZM-L-01 REV 01	1
29	PA-45	BOLT	1
30	PA-46	BOLT	1
31	PA-47	BOLT	1
32	90-04085	WASHER M5 X 11 X 1 NYLON 6/6 BLACK	1
33	90-04084	HEXAGON SOCKET BUTTON HEAD CAP SCREW ISO 7380 M5X16-8.8 ZM-F-11 REV 03	1
34	PA-48	WASHER	1
35	24-08157	REAR INNER FENDER NOTE: Supersedes part number 24-04438	1
36	24-07674	SDS STUBBY CHIN CENTER	1
37	90-04085	WASHER M5 X 11 X 1 NYLON 6/6 BLACK	1
38	90-04084	HEXAGON SOCKET BUTTON HEAD CAP SCREW ISO 7380 M5X16-8.8 ZM-F-11 REV 03	1
39	90-04085	WASHER M5 X 11 X 1 NYLON 6/6 BLACK	1
40	90-04084	HEXAGON SOCKET BUTTON HEAD CAP SCREW ISO 7380 M5X16-8.8 ZM-F-11 REV 03	1
41	24-06684	SDS CHIN FAIRING LEFT NOTE: Please order 80-08012 DECAL/GRAPHIC/MEDALLION GRAPHIC, CRAFTED IN CALIFORNIA JEWEL separately.	1
42	90-04084	HEXAGON SOCKET BUTTON HEAD CAP SCREW ISO 7380 M5X16-8.8 ZM-F-11 REV 03	1
43	90-04085	WASHER M5 X 11 X 1 NYLON 6/6 BLACK	1
44	90-04084	HEXAGON SOCKET BUTTON HEAD CAP SCREW ISO 7380 M5X16-8.8 ZM-F-11 REV 03	1
45	90-04084	HEXAGON SOCKET BUTTON HEAD CAP SCREW ISO 7380 M5X16-8.8 ZM-F-11 REV 03	1
46	90-04085	WASHER M5 X 11 X 1 NYLON 6/6 BLACK	1
47	90-04084	HEXAGON SOCKET BUTTON HEAD CAP SCREW ISO 7380 M5X16-8.8 ZM-F-11 REV 03	1
48	90-04085	WASHER M5 X 11 X 1 NYLON 6/6 BLACK	1
49	90-04085	WASHER M5 X 11 X 1 NYLON 6/6 BLACK	1
50	90-02109	HEXAGON SOCKET BUTTON HEAD CAP SCREW ISO 7380 M5X12-8.8 ZM-F-01	1
51	24-07746	STRUCTURAL PLASTIC SKID PAN	1
52	<i>Not Applicable to this Bike Model</i>		
53	<i>Not Applicable to this Bike Model</i>		
54	<i>Not Applicable to this Bike Model</i>		
55	<i>Not Applicable to this Bike Model</i>		
		HEXAGON SOCKET BUTTON HEAD CAP SCREW ISO 7380 M5X16-8.8 ZM-F-11 REV 01 ZM-L-01 REV 01	

56	90-07292	NOTE: Does not apply to DS	1
57	90-04085	WASHER M5 X 11 X 1 NYLON 6/6 BLACK	1
58	<i>Not Applicable to this Bike Model</i>		
59	<i>Not Applicable to this Bike Model</i>		
60	24-08027-6	FRONT FENDER STREET TO WORK WITH SHOWA SUSPENSION RED	1
61	<i>Not Applicable to this Bike Model</i>		
62	24-08235	SDS CHIN FAIRING RIGHT NOTE: Please order 80-08012 DECAL/GRAPHIC/MEDALLION GRAPHIC, CRAFTED IN CALIFORNIA JEWEL separately.	1
63	24-04428	SDS FAIRING FRONT CENTER BLACK#2	1
64	90-05885	PHILIPS HEAD SHEET METAL SCREW 6 X 1/2	1
65	24-08208-6	SR POWER TANK ASSEMBLY RED NOTE: This red plastic tank assembly should be used with a Power Tank only and includes the Zero logo and SR markings. NOTE: Can not be used on a Zero DS. Superseds 20-06723.	1
65	24-08208-1	SR POWER TANK ASSEMBLY BLACK	1
65	24-08208-4	SR POWER TANK ASSEMBLY WHITE	1
65	24-08208-7	SR POWER TANK ASSEMBLY YELLOW	1
66	24-08092	HEADLIGHT MOUNT LEFT FOR ABS	1
67	90-04084	HEXAGON SOCKET BUTTON HEAD CAP SCREW ISO 7380 M5X16-8.8 ZM-F-11 REV 03	1
68	90-04085	WASHER M5 X 11 X 1 NYLON 6/6 BLACK	1
69	24-08091	HEADLIGHT MOUNT RIGHT FOR ABS	1
70	27-08034	12V ACCESSORY COVER, SMALL	1
71	10-07504	12V ACCESSORY SOCKET KIT - SDS NOTE: Charge a GPS, smart phone or mp3 player using the Zero Motorcycles 12V Accessory Socket Kit. Designed to connect directly to your motorcycle{###}'s power port harness, the accessory socket enables you to charge small devices that have a cigarette lighter plug. The accessory outlet is rated up to 10 amps/120 watts. This kit includes all mounting hardware for installation on the 2014 and later Zero S, Zero DS and Zero SR motorcycles. NOTE: 2014 [Zero SR, Zero S, Zero DS] 2015 [Zero SR, Zero S, Zero DS] 2016-2018 [Zero SR, Zero S, Zero DS, Zero DSR]	1
72	90-07265	HEXAGON SOCKET HEAD CAP SCREW ISO 4762 M6X20-8.8 ZM-F-01 REV 03 ZM-L-01 REV 01	1
73	24-02961	MIRROR MOUNT CLAMP	1
74	26-08060	MIRROR LH MOUNT LOW PROFILE NOTE: Bottom part of the mirror mount LH	1
75	27-08082	HAND GRIP THROTTLE SIDE NOTE: Grip does not have Zero logo. Order with 27-08083 if you want a matching pair. NOTE: Supersedes p/n 27-08006.	1

ZEV0026 - Rear Suspension

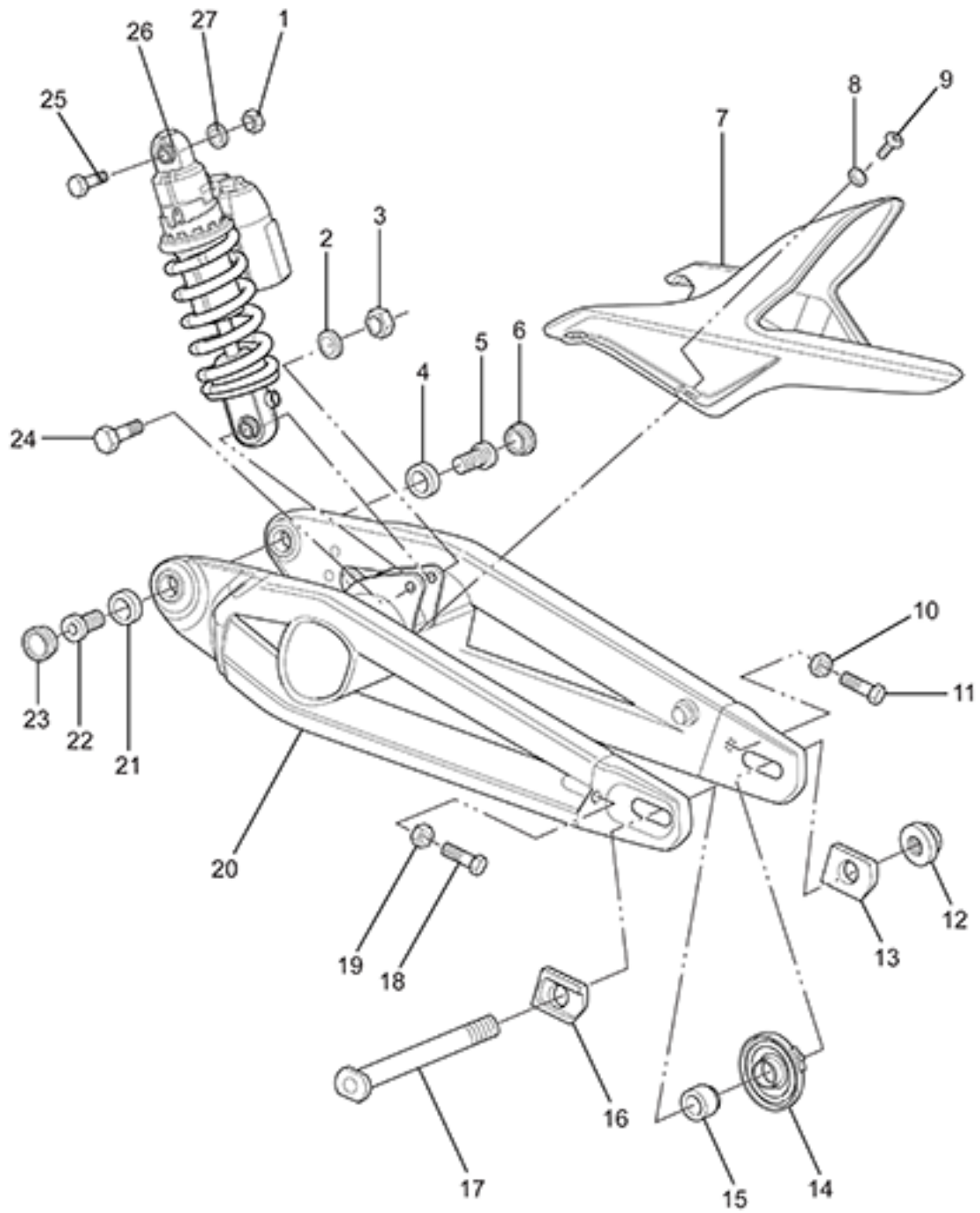

ZEV0026 - Rear Suspension

Callout	Part Number	Part Name	Qty. per Motorcycle
1	90-02050	PREVAILING TORQUE TYPE NUT DIN 985 M10-08 ZM-F-01	1
2	90-02100	WASHER ISO 7089 10-200 HV ZM-F-01	1
3	90-02050	PREVAILING TORQUE TYPE NUT DIN 985 M10-08 ZM-F-01	1
4	20-06138	BEARING 6204 NOTE: Bearing used as swing arm bearing in some models and as the wheel bearing (qty of 5; 2 in front and three in rear wheel) in 2015 and later models. NOTE: Manufacturer part number is 6204-2RS	1
5	20-06130	STUB AXLE	1
6	20-06937	SDS STUB-PIVOT COVER	1
7	24-04438	REAR INNER FENDER NOTE: Superseded by 24-08157	1
8	90-04085	WASHER M5 X 11 X 1 NYLON 6/6 BLACK	1
9	90-02109	HEXAGON SOCKET BUTTON HEAD CAP SCREW ISO 7380 M5X12-8.8 ZM-F-01	1
10	90-05088	HEXAGON FLANGE NUT DIN 6923 M8-1.25 ZM-F-01 REV 03 NOTE: Axle adjusters jam nut	1
11	90-03030	HEXAGON HEAD SCREW DIN 933 M8X40-10.9 ZM-F-01 REV 03	1
12	90-05678	U-NUT M20X1.5 FLANGE 27S 15H NOTE: Rear Axle Nut	1
13	20-04738	REAR AXLE ADJUSTER PUSH BLOCK, NUT SIDE	1
14	45-07496	MPI WHEEL SPEED SENSOR	1
15	23-07489	WHEEL SPACER DRIVE SIDE REAR	1
16	20-04737	REAR AXLE ADJUSTER PUSH BLOCK, HEAD SIDE	1
17	23-04736	AXLE 20MM HOLLOW NOTE: Superseded by pn:23-08032	1
18	90-03030	HEXAGON HEAD SCREW DIN 933 M8X40-10.9 ZM-F-01 REV 03	1
19	90-05088	HEXAGON FLANGE NUT DIN 6923 M8-1.25 ZM-F-01 REV 03 NOTE: Axle adjusters jam nut	1
20	21-07747	S SWINGARM	1
21	20-06138	BEARING 6204 NOTE: Bearing used as swing arm bearing in some models and as the wheel bearing (qty of 5; 2 in front and three in rear wheel) in 2015 and later models. NOTE: Manufacturer part number is 6204-2RS	1
22	20-06130	STUB AXLE	1
23	20-06937	SDS STUB-PIVOT COVER	1
24	90-05711	LOWER SHOCK EYE BOLT M10-1.5X60MM	1

25	90-05711	LOWER SHOCK EYE BOLT M10-1.5X60MM	1
26	22-05881	S SHOCK 40MM NOTE: not applicable in DS	1
27	90-02100	WASHER ISO 7089 10-200 HV ZM-F-01	1





ZEV0027 - Frame(Left)

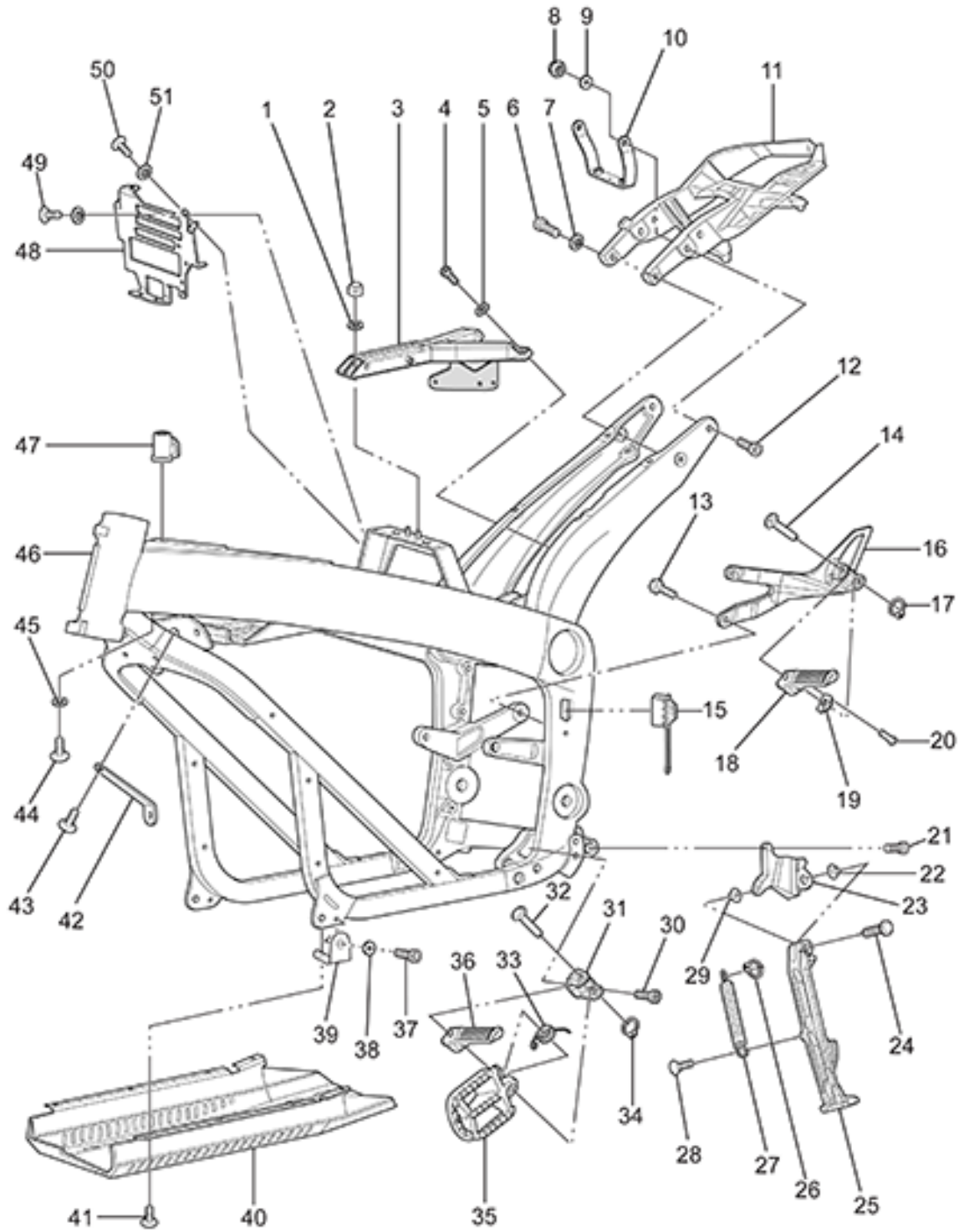

## ZEV0027 - Frame(Left)

Callout	Part Number	Part Name	Qty. per Motorcycle
1	90-02103	WASHER ISO 7089 6-200HV ZM-F-01	1
2	90-02054	PREVAILING TORQUE TYPE NUT DIN 985 M6-08 ZM-F-01	1
3	21-06979	SDS SEAT FRAME WITH FUSEPANEL MOUNT	1
4	90-02122	HEXAGON SOCKET BUTTON HEAD CAP SCREW ISO 7380 M6X16-8.8 ZM-F-01 REV 03	1
5	90-02103	WASHER ISO 7089 6-200HV ZM-F-01	1
6	<i>Not Applicable to this Bike Model</i>		
7	90-02104	WASHER ISO 7089 -8-200 HV ZM-F-01	1
8	90-03236	PREVAILING TORQUE TYPE NUT DIN 985 M8-10 ZM-F-01	0
9	90-02104	WASHER ISO 7089 -8-200 HV ZM-F-01	1
10	20-05897	HEATSINK SUPPORT	1
11	20-05883	SR TAIL FRAME	1
12	90-08005	SEAT BOLT M8X55 NOTE: Supersedes 90-07009.	1
13	90-07284	HEX FLANGE BOLT M8X25	1
14	90-02725	CLEVIS PIN CUSTOM 10MM X 45L	1
15	45-04864	AC CHARGE INLET COVER	1
16	20-04285	SDS PASSENGER PEG BRKT L	1
17	90-02879	RETAINING RING 9MM SHAFT DIN 471	1
18	27-08039	PASSENGER FOOTPEG LEFT SIDE	1
19	20-04279	FOOTPEG DETENT PLATE	1
20	20-05404	FOOTPEG DETENT BALL MECHANISM	1
21	90-07277	HEXAGON SOCKET THIN HEAD CAP SCREW DIN 7984 M10X25-8.8 ZM-F-01 REV 03 ZM-L-01 REV 01	1
22	90-02800	BUSHING FLANGE 0.375	1
23	20-06590	KICKSTAND MOUNT	1
24	90-02799	CLEVIS PIN CUSTOM NOTE: Used to attach kickstand leg to mount.	1
25	20-05660	SHORT KICKSTAND LEG W/MAGNET	1
26	90-02837	E CLIP 0.375	1
27	90-08219	SIDESTAND SPRING OUTER STAINLESS PASSIVATED	1
28	90-07261	HEXAGON SOCKET COUNTERSUNK HEAD SCREW ISO 10642 M8X20-10.9 ZM-F-01 REV 03 ZM-L-01 REV 01	1
29	90-02800	BUSHING FLANGE 0.375	1
30	90-07277	HEXAGON SOCKET THIN HEAD CAP SCREW DIN 7984 M10X25-8.8 ZM-F-01 REV 03 ZM-L-01 REV 01	1
31	20-02723	CLEVIS FOOT PEG UNIVERSAL LEFT	1
32	90-02725	CLEVIS PIN CUSTOM 10MM X 45L	1
33	20-02727	TORSION SPRING, .678 OD .078 WIRE, CCW	1
34	90-02879	RETAINING RING 9MM SHAFT DIN 471	1

35	<i>Not Applicable to this Bike Model</i>		
36	27-08037	RIDER FOOTPEG LEFT SIDE STREET	1
37	90-07288	HEXAGON SOCKET HEAD CAP SCREW ISO 4762 M5X12-8.8 ZM-F-01 REV 03 ZM-L-01 REV 01	1
38	PA-51	M5 FLAT WASHER	1
39	20-05307	SKID PAN BRACKET	1
40	24-07746	STRUCTURAL PLASTIC SKID PAN	1
41	90-02109	HEXAGON SOCKET BUTTON HEAD CAP SCREW ISO 7380 M5X12-8.8 ZM-F-01	1
42	20-07073	SDS FRAME MOUNTED HORN BRACKET	1
43	90-02128	HEXAGON SOCKET BUTTON HEAD CAP SCREW ISO 7380 M8X20-8.8 ZM-F-01 REV 03	1
44	90-07281	HEXAGON SOCKET BUTTON HEAD SCREWS ISO 7380 M6X12-8.8 ZM-F-01 REV 03 ZM-L-01 REV 01	1
45	90-02103	WASHER ISO 7089 6-200HV ZM-F-01	1
46	26-08128	SR MAIN FRAME NOTE: Must supply VIN# and Warranty Claim# when ordering. NOTE: Also for DSR Main frame	1
46	26-08128	SR MAIN FRAME NOTE: Must supply VIN# and Warranty Claim# when ordering. NOTE: Also for DSR Main frame	1
47	20-05202	KEYSWITCH LOCK AND TANK BAG LOCK COMBO KIT NOTE: This Kit includes an ignition lock (45-02692) and a tank bag/helmet lock (p/n 20-05044) that have been keyed alike with two keys.	1
48	20-07736	ELECTRICAL PANEL MOUNT PLATE NOTE: Superseded by 26-08120.	1
49	PA-52	ELECTRICAL BRACKET BOLT HEX HEAD M5 - 0.80 X 12MM	1
50	PA-53	ELECTRICAL BRACKET BOLT HEX HEAD M5 - 0.80 X 12MM	1
51	PA-54	ELECTRICAL PANEL BOLT WASHER, M5 FLAT WASHER	1



ZEV0028 - Frame(Right)

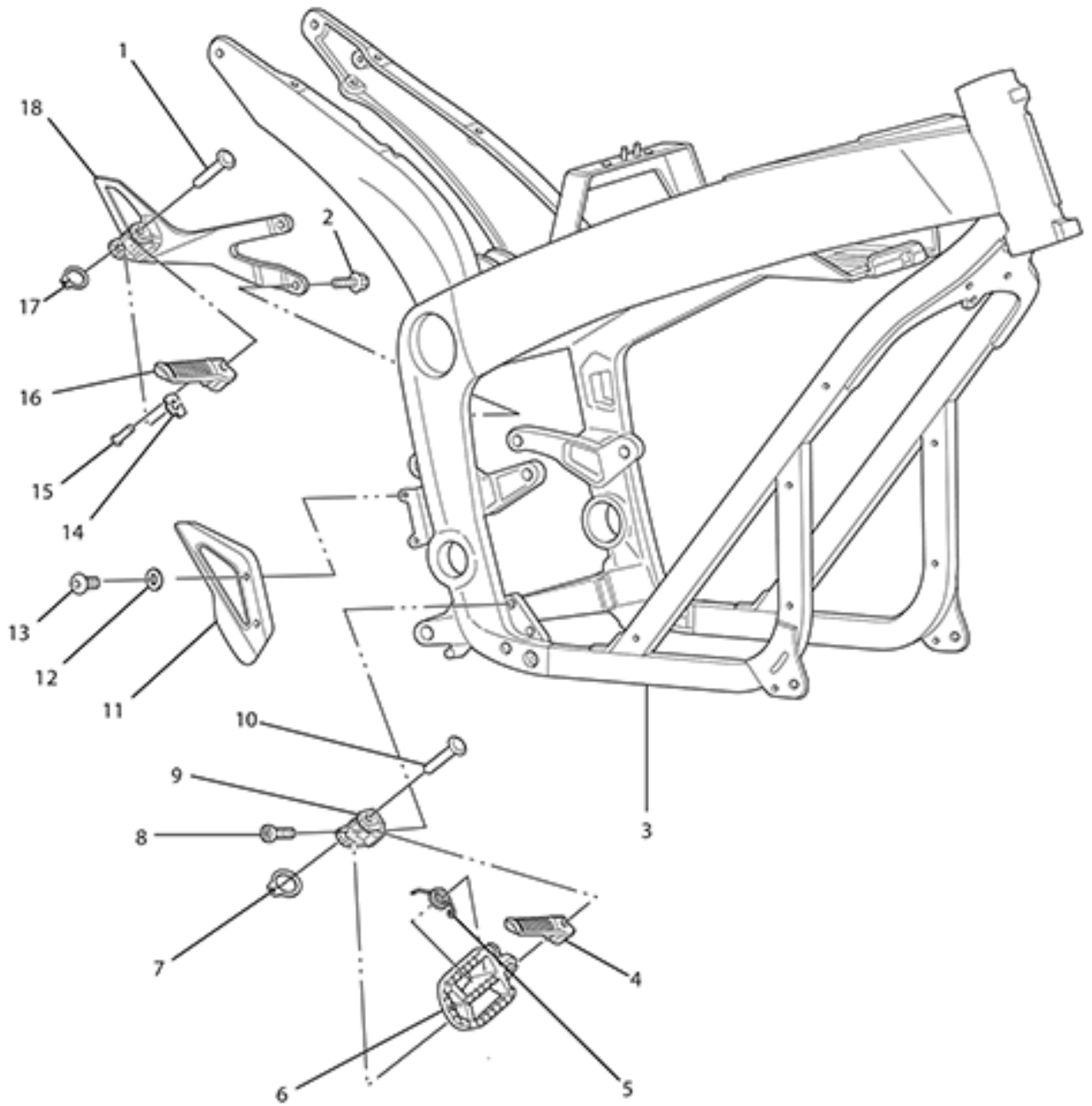

## ZEV0028 - Frame(Right)

Callout	Part Number	Part Name	Qty. per Motorcycle
1	90-02725	CLEVIS PIN CUSTOM 10MM X 45L	1
2	90-07284	HEX FLANGE BOLT M8X25	1
3	26-08102	FRAME SR NOTE: Must supply VIN# and Warranty Claim# when ordering. NOTE: Superseded by 26-08128.	1
3	26-08128	SR MAIN FRAME NOTE: Must supply VIN# and Warranty Claim# when ordering. NOTE: Also for DSR Main frame	1
4	27-08036	RIDER FOOTPEG RIGHT SIDE STREET	1
5	20-02727	TORSION SPRING, .678 OD .078 WIRE, CCW	1
6	<i>Not Applicable to this Bike Model</i>		
7	90-02879	RETAINING RING 9MM SHAFT DIN 471	1
8	90-07277	HEXAGON SOCKET THIN HEAD CAP SCREW DIN 7984 M10X25-8.8 ZM-F-01 REV 03 ZM-L-01 REV 01	1
9	20-02724	CLEVIS FOOT PEG UNIVERSAL RIGHT	1
10	90-02725	CLEVIS PIN CUSTOM 10MM X 45L	1
11	25-07457	MASTER CYLINDER GUARD FOR J-JUAN MASTER CYLINDER	1
12	90-02103	WASHER ISO 7089 6-200HV ZM-F-01	1
13	90-07323	HEXAGON SOCKET BUTTON HEAD CAP SCREW ISO 7380 M6X25-8.8 ZM-F-01 REV 03 ZM-L-01 REV 01	1
14	20-04279	FOOTPEG DETENT PLATE	1
15	20-05404	FOOTPEG DETENT BALL MECHANISM	1
16	27-08038	PASSENGER FOOTPEG RIGHT SIDE	1
17	90-02879	RETAINING RING 9MM SHAFT DIN 471	1
18	20-07604	SDS AND FX PASSENGER PEG BRKT R	1

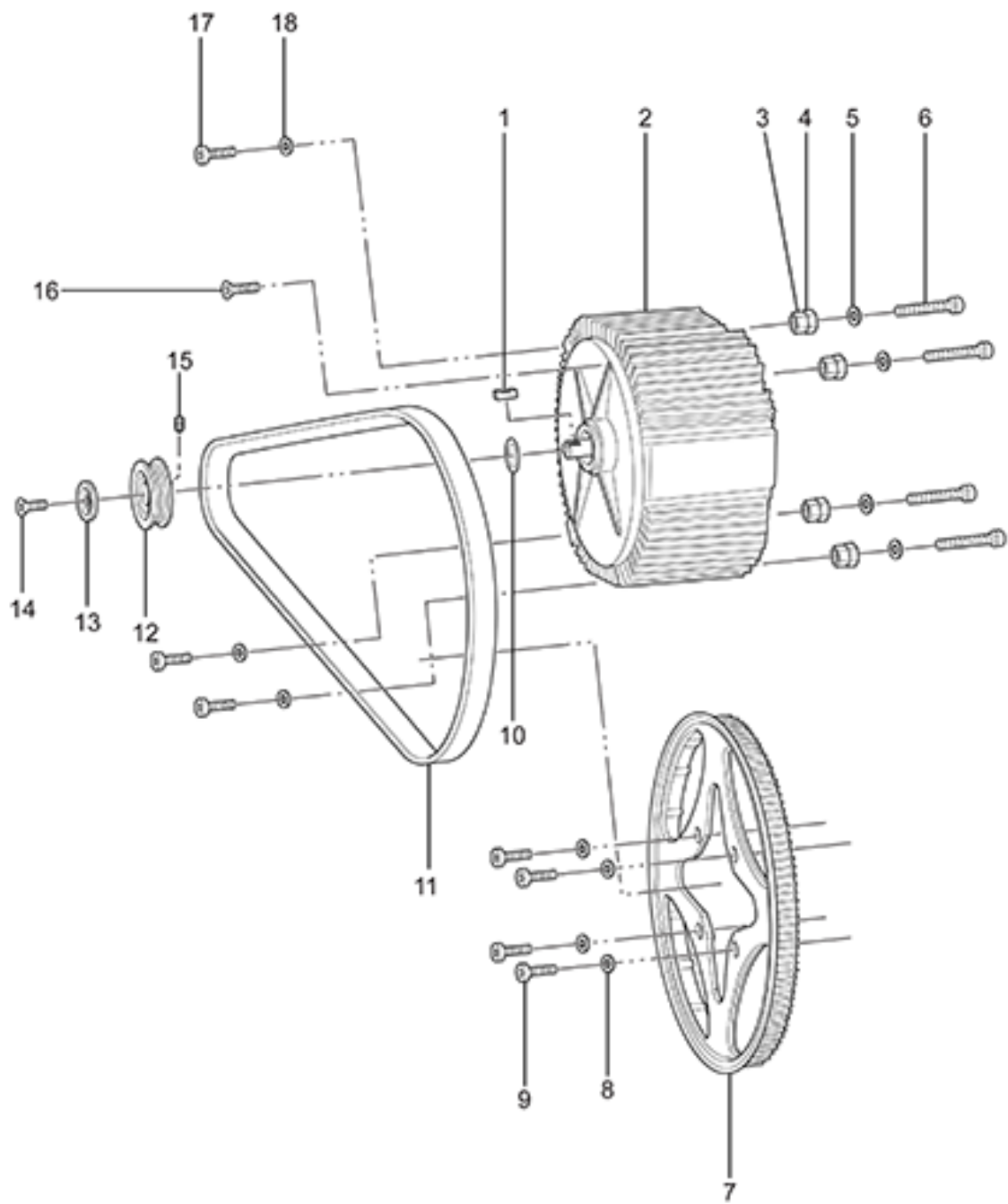



ZEV0029 - Motor and Drive System

Callout	Part Number	Part Name	Qty. per Motorcycle
1	30-06745	SHAFT KEY .25 MOTOR SPROCKET NOTE: Motor Sprocket	1
2	12-08039	ZF75-7 R IPM 30T MOTOR KIT	1
3	90-04783	HEXAGON NUT ISO 4033 M14-2 ZM-F-01 REV 03	1
4	20-04774	MOTOR JACK SCREW INNER	1
5	90-02104	WASHER ISO 7089 -8-200 HV ZM-F-01	1
6	90-05179	HEXAGON SOCKET HEAD CAP SCREW ISO 4762 M8X60-8.8 ZM-F-01 REV 03	1
7	30-08034	WHEEL SPROCKET 130T 8MM PITCH FINISHED	1
8	90-02104	WASHER ISO 7089 -8-200 HV ZM-F-01	1
9	90-07289	HEXAGON SOCKET THIN HEAD CAP SCREW DIN 7984 M8X30-8.8 ZM-F-01 REV 03 ZM-L-01 REV 01 NOTE: THIN HEAD CAP SCREW DIN 7984 M8X30-8.8	1
10	<i>Not Applicable to this Bike Model</i>		
11	30-08084	BELT DRIVE, 220T, 8MM PITCH, 14MM WIDE, NEW LOGO	1
12	30-03658	SPROCKET FRONT, BELT DRIVE 30T, 8MM PITCH, 15MM WIDE 1" BORE NOTE: Applies to SR only	1
13	20-05453	LOW PROFILE BELT SPROCKET MOTOR SHAFT TOPHAT	1
14	90-02056	HEXAGON SOCKET COUNTERSUNK HEAD SCREW M10X25-8.8 MOTOR SHAFT NOTE: Bolt used to hold front sprocket in place onto the motor shaft. NOTE: Sprocket	1
15	<i>Not Applicable to this Bike Model</i>		
16	90-08037	HEXALOBULAR (6 LOBE) SOCKET FLAT HEAD COUNTERSUNK SCREW ISO 14582 M8X30-10.9 ZM-F-01 REV 04	1
17	90-02096	MOTOR MOUNTING LEFT FRONT TOP AND LEFT FRONT BOTTOM BOLT	1
18	90-02104	WASHER ISO 7089 -8-200 HV ZM-F-01	1

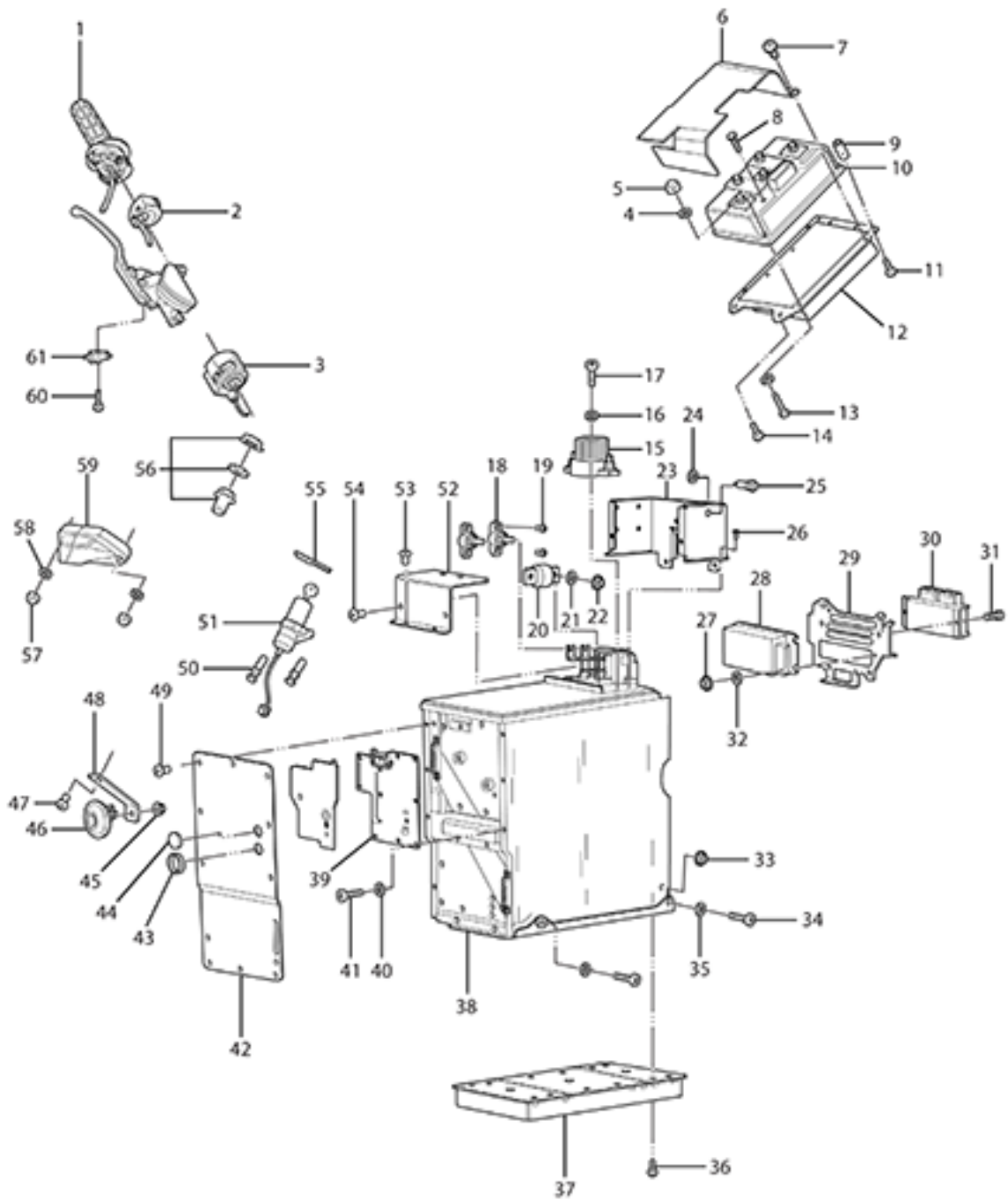

Callout	Part Number	Part Name	Qty. per Motorcycle
1	45-08039	THROTTLE BITRON HALL EFFECT PCB NOTE: Supersedes 27-08000	1
2	40-06054	KILL MODE START SWITCH	1
3	60-07780	LEFT HAND SWITCHGEAR ECIE	1
4	90-02103	WASHER ISO 7089 6-200HV ZM-F-01	1
5	90-02071	HEXAGON NUT ISO 4032 M6-8 ZM-F-01 REV 02	1
6	24-08067	BODYWORK MISC #6 CONTROLLER UN-SHIELDED COVER	1
7	90-06250	CONTROLLER FORMEX PAN HEAD PHILLIPS #6 SHEET METAL SCREW	1
8	90-07063	CONTROLLER LEAD BOLTS M8X16	1
9	<i>Not Applicable to this Bike Model</i>		
10	60-07008	CONTROLLER SIZE 6 GEN 4 SEVCON	1
11	90-05179	HEXAGON SOCKET HEAD CAP SCREW ISO 4762 M8X60-8.8 ZM-F-01 REV 03	1
12	30-08067	R CONTROLLER HEATSINK	1
13	90-03251	HEXAGON SOCKET HEAD CAP SCREW ISO 4762 M6X30-8.8 ZM-F-01	1
14	90-07268	HEXAGON SOCKET HEAD CAP SCREW ISO 4762 M8X25-10.9 ZM-F-01 REV 03 ZM-L-01 REV 01	1
15	60-06705	CONTACTOR GIGAVAC GX11 12/40VDC COIL	1
16	90-02101	WASHER ISO 7089 5-200HV ZM-F-01	1
17	90-07129	HEXAGON SOCKET BUTTON HEAD SCREW ISO 7380 M5X30-8.8 ZM-F-01 ZM-L-02	1
18	45-08058	JUNCTION POST SMALL TRIMMED	1
19	90-07125	HEXAGON SOCKET BUTTON HEAD SCREW ISO 7380 M5X10	1
20	45-05224	FUSE 300A 160VDC CLASS T	1
21	90-02100	WASHER ISO 7089 10-200 HV ZM-F-01	1
22	<i>Not Applicable to this Bike Model</i>		
23	<i>Not Applicable to this Bike Model</i>		
24	40-07614	ASSY BATTERY SDS 4-MOD 15MY IMPL NOTE: Superseded by part number 46-08034.	1
25	PA-225	LV FUSE HOLDER	1
26	PA-226	BATTERY BOX SCREW	1
27	90-02054	PREVAILING TORQUE TYPE NUT DIN 985 M6-08 ZM-F-01	1
28	60-07190	DC-DC CONV 500W SEVCON 622-11211 ABS UNITS	1
29	20-07736	ELECTRICAL PANEL MOUNT PLATE NOTE: Superseded by 26-08120.	1
30	40-07671	ASSY MBB GENERIC 15MY IMPL NOTE: NOTE: Need to provide motorcycle VIN in shipping notes. NOTE: If 11kW please order 40-08074	1

31	90-02515	HEXAGON SOCKET HEAD CAP SCREW ISO 4762 M4X12-8.8 ZM-F-01 REV 03	1
32	90-02103	WASHER ISO 7089 6-200HV ZM-F-01	1
33	90-03236	PREVAILING TORQUE TYPE NUT DIN 985 M8-10 ZM-F-01	1
34	90-02098	HEXAGON SOCKET HEAD CAP SCREW ISO 4762 M8X40-8.8 ZM-F-01 REV 02	1
35	90-02104	WASHER ISO 7089 -8-200 HV ZM-F-01	1
36	90-02109	HEXAGON SOCKET BUTTON HEAD CAP SCREW ISO 7380 M5X12-8.8 ZM-F-01	1
37	45-08253	ONBOARD CHARGER 1300W NOTE: Current design includes additional ferrite. Please contact Zero Motorcycles Service Team if you need additional guidance on routing. NOTE: Supersedes 45-08123 and 45-08234.	1
38	46-08227	ASSEMBLY BATTERY MONOLITH ZF14.4 NOTE: Motorcycle VIN#, Case# or Claim# must be provided when ordering NOTE: 2014 - FOR INSTALLING IN 2014 MODELS, INCLUDE 12-08080 IN THE ORDER. IN CASE OF THE BIKE HAVING A POWER TANK, ALSO INCLUDE 12-08011 NOTE: 2013 -FOR INSTALLING IN 2013 MODELS, INCLUDE TO ORDER 12-08057	1
39	40-08031	BMS PCB ASSY POTTED 17MY IMPL NOTE: PLEASE INCLUDE VIN# OF BIKE AND BATTERY SERIAL # FOR PROGRAMMING PURPOSES NOTE: FOR FX/FXP, IF BATTERY SERIAL NUMBER STARTS WITH 14SG**** PLEASE ORDER 41-06419	1
40	90-02102	WASHER ISO 7089 4-200HV ZM-F-01	1
41	90-07127	HEXAGON SOCKET HEAD CAP SCREW ISO 4762 M4X5-8.8 ZM-F-01 REV 03 ZM-L-02 REV 01	1
42	<i>Not Applicable to this Bike Model</i>		
43	20-04094	PLUG DIAG PORT 24.50 THRU 26.00 MM 12MY IMPL	1
44	80-08003	BATTERY FRONT UPPER FILLER PLUG	1
45	90-02054	PREVAILING TORQUE TYPE NUT DIN 985 M6-08 ZM-F-01	1
46	45-06774	DISC HORN K70/H12 V WITH BLACK ZINC	1
47	90-02128	HEXAGON SOCKET BUTTON HEAD CAP SCREW ISO 7380 M8X20-8.8 ZM-F-01 REV 03	1
48	20-07073	SDS FRAME MOUNTED HORN BRACKET	1
49	90-07124	HEXAGON SOCKET BUTTON HEAD SCREW ISO 7380 M5X6-8.8	1
50	90-02937	M8X14MM BREAK AWAY HEX BOLT NOTE: One Time Use Bolt	1
51	20-05202	KEYSWITCH LOCK AND TANK BAG LOCK COMBO KIT NOTE: This Kit includes an ignition lock (45-02692) and a tank bag/helmet lock (p/n 20-05044) that have been keyed alike with two keys.	1

52	<i>Not Applicable to this Bike Model</i>		
53	90-07124	HEXAGON SOCKET BUTTON HEAD SCREW ISO 7380 M5X6-8.8	1
54	90-07124	HEXAGON SOCKET BUTTON HEAD SCREW ISO 7380 M5X6-8.8	1
55	20-07062	SDS TRIPLE CLAMP HARNESS SUPPORT	1
56	10-07504	<p>12V ACCESSORY SOCKET KIT - SDS</p> <p>NOTE: Charge a GPS, smart phone or mp3 player using the Zero Motorcycles 12V Accessory Socket Kit. Designed to connect directly to your motorcycle{###}'s power port harness, the accessory socket enables you to charge small devices that have a cigarette lighter plug. The accessory outlet is rated up to 10 amps/120 watts. This kit includes all mounting hardware for installation on the 2014 and later Zero S, Zero DS and Zero SR motorcycles.</p> <p>NOTE: 2014 [Zero SR, Zero S, Zero DS] 2015 [Zero SR, Zero S, Zero DS] 2016-2018 [Zero SR, Zero S, Zero DS, Zero DSR]</p>	1
57	90-02054-1	M6 X 8MM NUT	1
58	90-02103	WASHER ISO 7089 6-200HV ZM-F-01	1
59	40-08156	DASH LCD NOTE: Supersedes 40-08119	1
60	PA-220	BRAKE LIGHT SWITCH SCREW	1
61	PA-221	BRAKE LIGHT SWITCH NOTE: Not sold separately. Please order the Master Cylinder.	1