

Zero Motocycles
FXS 2016 Exploded Views

ZEV0022 - Braking

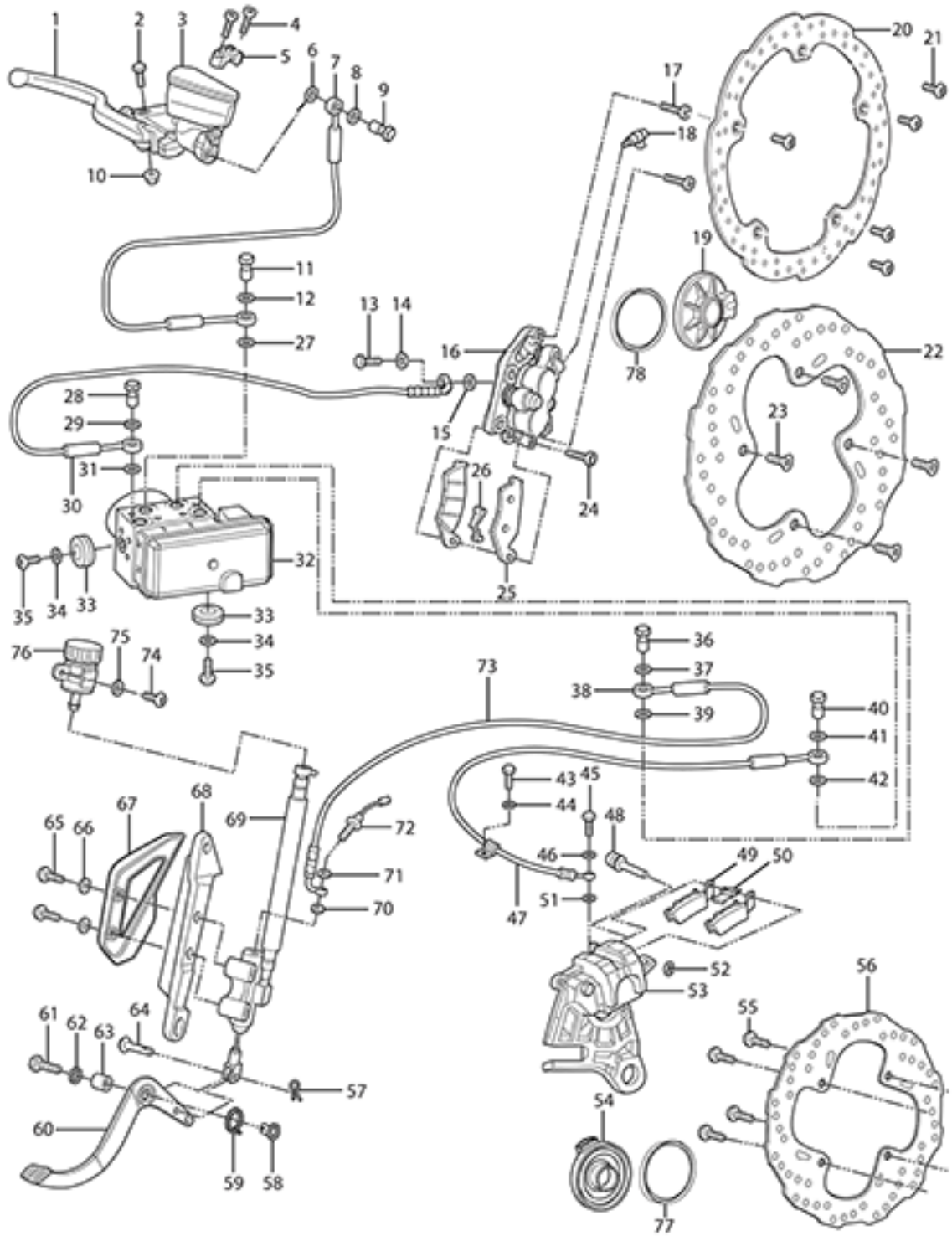

ZEV0022 - Braking

Callout	Part Number	Part Name	Qty. per Motorcycle
1	25-08032	SDS BRAKE JJUAN LEVER	1
2	PA-126	BRAKE LEVER PIVOT BOLT	1
3	25-07682	JJUAN 12.7MM FRONT MASTER CYLINDER SDS/FXS	1
4	25-08033	JJUAN FRONT MC RESERVOIR CAP SERVICE KIT NOTE: cap, diapharom, screws	1
5	25-08064	FRONT MASTER CYLINDER CLAMP KIT NOTE: SDS/XMX NOTE: Mount and Bolts NOTE: Upper Mirror Mount RH	1
6	PA-128	BANJO GASKET	1
7	25-07827	FX FRONT BRAKE LINE MC TO HCU	1
8	PA-128	BANJO GASKET	1
9	PA-129	BANJO BOLT MC	1
10	PA-130	BRAKE LEVER PIVOT BOLT NUT	1
11	PA-131	BANJO BOLT AND HCU	1
12	PA-128	BANJO GASKET	1
13	PA-132	BANJO BOLT FRONT CALIPER	1
14	PA-128	BANJO GASKET	1
15	PA-128	BANJO GASKET	1
16	25-07686	JJUAN 32/30MM FRONT CALIPER SDS	1
17	90-08029	HEXAGON HEAD SCREW ISO 4762 M10-1.25X40-10.9 ZM-F-01 REV03 ZM-L-01 REV01	1
18	PA-133	BLEEDER VALVE	1
19	45-07496	MPI WHEEL SPEED SENSOR	1
20	25-07702	BRAKE ROTOR 320MM FIXED	1
21	90-07833	CUSTOM ROTOR BOLT M8X23MM SHOULDER SCREW	1
22	<i>Not Applicable to this Bike Model</i>		
23	<i>Not Applicable to this Bike Model</i>		
24	90-08029	HEXAGON HEAD SCREW ISO 4762 M10-1.25X40-10.9 ZM-F-01 REV03 ZM-L-01 REV01	1
25	25-08029	BRAKE PADS SET FRONT SDS	1
26	PA-139	REAR BAKE PAD ANTI RATTLE CLIP	1
27	PA-128	BANJO GASKET	1
28	PA-131	BANJO BOLT AND HCU	1
29	PA-128	BANJO GASKET	1
30	25-08088	FXS FRONT BRAKE LINE HCU TO CALIPER	1
31	PA-128	BANJO GASKET	1
32	25-08092	BOSCH ABS HCU FLUID FILLED 6 PROFILE VARIANTS NOTE: Supersedes part number 25-08081 and 25-08082.	1
33	90-08027	GROMMET VIBRATION ISOLATION M6	1

34	90-02105	WASHER ISO 7093-1 6-200 HV ZM-F-01 REV 02	1
35	90-07273	HEXAGON SOCKET BUTTON HEAD CAP SCREW ISO 7380 M6X16-8.8 ZM-F-01 REV 03 ZM-L-01 REV 01	1
36	PA-131	BANJO BOLT AND HCU	1
37	PA-128	BANJO GASKET	1
38	25-07822	FX REAR BRAKE LINE MC TO HCU	1
39	PA-128	BANJO GASKET	1
40	PA-131	BANJO BOLT AND HCU	1
41	PA-128	BANJO GASKET	1
42	PA-128	BANJO GASKET	1
43	90-07292	HEXAGON SOCKET BUTTON HEAD CAP SCREW ISO 7380 M5X16-8.8 ZM-F-11 REV 01 ZM-L-01 REV 01	1
44	90-02105	WASHER ISO 7093-1 6-200 HV ZM-F-01 REV 02	1
45	PA-136	BANJO BOLT REAR CALIPER	1
46	PA-128	BANJO GASKET	1
47	25-08094	XMV REAR BRAKE LINE HCU TO CALIPER NOTE: Supersedes part number 25-07823.	1
48	PA-137	REAR CALIPER SLIDE BOLT	1
49	25-08030	BRAKE PAD SET SDS REAR	1
50	PA-139	REAR BRAKE PAD ANTI RATTLE CLIP	1
51	PA-128	BANJO GASKET	1
52	PA-140	REAR CALIPER SLIDE BOLT CLIP	1
53	25-08083	JJUAN 34MM REAR CALIPER SDS NOTE: replacing old p/n: 25-08008	1
54	45-07496	MPI WHEEL SPEED SENSOR	1
55	90-08015	HEX SOCKET BUTTON HEAD SCREW M8X20 NOTE: Superseded by 90-07516.	1
56	25-08057	BRAKE ROTOR 240MM SDS/XMV COMMON	1
57	PA-27	COTTER PIN	1
58	20-02465	IGLIDE BEARING GFM-1416-06	1
59	20-05184	SPRING TORSION X BRAKE PEDAL	1
60	25-08072	BRAKE PEDAL OFF ROAD PEG NOTE: PEG ONLY EXCL. PEDAL BASE NOTE: FOR PEDAL BASE, PLEASE ORDER 25-08071	1
61	PA-141	BRAKE PEDAL PIVOT BOLT	1
62	20-02465	IGLIDE BEARING GFM-1416-06	1
63	20-02455	X BRAKE PEDAL SPACER	1
64	90-02133	1/4 X 3/4 CLEVIS PIN STEEL ZINC	1
65	90-07323	HEXAGON SOCKET BUTTON HEAD CAP SCREW ISO 7380 M6X25-8.8 ZM-F-01 REV 03 ZM-L-01 REV 01	1
66	90-02103	WASHER ISO 7089 6-200HV ZM-F-01 REV 02	1
67	25-07457	MASTER CYLINDER GUARD FOR J-JUAN MASTER CYLINDER	1
68	20-06295	REAR MASTER CYLINDER BRACKET XMV M6 THRU	1
69	25-08076	JJUAN 12MM REAR MASTER CYLINDER SM	1

70	PA-128	BANJO GASKET	1
71	PA-128	BANJO GASKET	1
72	PA-144	REAR BRAKE LIGHT SWITCH NOTE: Not sold separately. Please order the Master Cylinder.	1
73	25-08094	XMX REAR BRAKE LINE HCU TO CALIPER NOTE: Supersedes part number 25-07823.	1
74	90-07273	HEXAGON SOCKET BUTTON HEAD CAP SCREW ISO 7380 M6X16-8.8 ZM-F-01 REV 03 ZM-L-01 REV 01	1
75	90-02103	WASHER ISO 7089 6-200HV ZM-F-01 REV 02	1
76	25-07682	JJUAN 12.7MM FRONT MASTER CYLINDER SDS/FXS	1
77	25-08080	ABS MAGNET RING	1
78	25-08080	ABS MAGNET RING	1

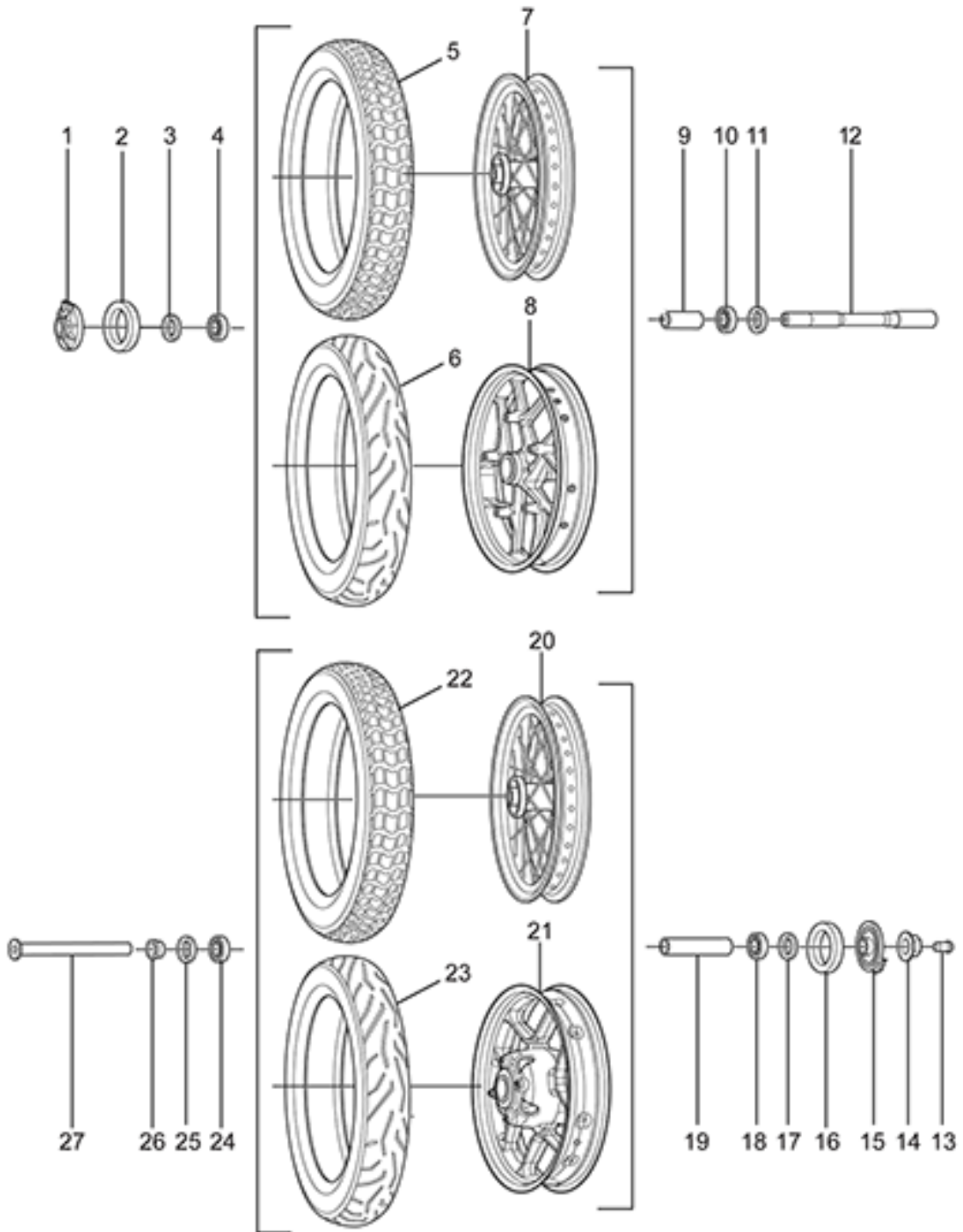

ZEV0023 - Wheel Assy

Callout	Part Number	Part Name	Qty. per Motorcycle
1	45-07496	MPI WHEEL SPEED SENSOR	1
2	25-08080	ABS MAGNET RING	1
3	PA-198	FRONT WHEEL SEAL	1
4	PA-199	FRONT WHEEL BEARING	1
5	<i>Not Applicable to this Bike Model</i>		
6	23-07668	PIRELLI DIABLO ROSSO II, 110/70R17 M/C 54H	1
7	<i>Not Applicable to this Bike Model</i>		
8	23-08056-4	WHEEL 3.50X17 SDS REAR CAST WHEEL ASSY 16MY IMPL BLACK-SILVER C	1
9	PA-145	FRONT WHEEL BEARING SPACER	1
10	PA-199	FRONT WHEEL BEARING	1
11	PA-198	FRONT WHEEL SEAL	1
12	23-07491	HOLLOW AXLE FRONT	1
13	20-05792	AXLE COVER NOTE: USED ONLY ON EU FX	1
14	90-05678	U-NUT M20X1.5 FN 27S 15H (REAR AXLE NUT) NOTE: Rear Axle Nut	1
15	45-07496	MPI WHEEL SPEED SENSOR	1
16	25-08080	ABS MAGNET RING	1
17	PA-201	REAR WHEEL SEAL	1
18	PA-202	REAR WHEEL BEARING	1
19	PA-203	REAR INNER BEARING SPACER	1
20	<i>Not Applicable to this Bike Model</i>		
21	23-08056-4	WHEEL 3.50X17 SDS REAR CAST WHEEL ASSY 16MY IMPL BLACK-SILVER C	1
22	<i>Not Applicable to this Bike Model</i>		
23	23-07669	PIRELLI DIABLO ROSSO II, 140/70R17 M/C 66H	1
24	PA-202	REAR WHEEL BEARING	1
25	PA-201	REAR WHEEL SEAL	1

ZEV0024 - Steering Systems

Callout	Part Number	Part Name	Qty. per Motorcycle
1	90-02094	HEXAGON SOCKET HEAD CAP SCREW ISO 4762 M8X25-10.9 ZM-F-01 REV 03	1
2	22-00687	S HANDLEBAR CLAMP	1
3	27-08050	HIGH RISE OFF-ROAD HANDLEBAR NOTE: Supersedes 27-08032.	1
4	22-00688	S HANDLEBAR RISER	1
5	22-06279	STEERING STEM THIN NUT M27 X 1.5 X 8MM	1
6	20-06278	WASHER 41 - 27.5 X 2 MM	1
7	90-07268	HEXAGON SOCKET HEAD CAP SCREW ISO 4762 M8X25-10.9 ZM-F-01 REV 03 ZM-L-01 REV 01	1
8	22-07625	XXM UPPER TRIPLE CLAMP 15MY IMP	1
9	22-06257	STEERING STEM LOCK NUT M 30 X1.5 MM	1
10	81-08045	BEARING LIP SEAL OVERMOLDED 55MM OD NOTE: Supersedes part 20-06113	1
11	20-06068	STEERING HEAD BEARING KOYO SAC3055-1	1
12	90-02043	TOOTHED LOCK WASHER WITH EXTERNAL TEETH DIN 6797 A M10-B85 ZM-F-01 REV 02	1
13	90-07259	HANDLE BAR RISER CAP SCREW M10X35	1
14	20-06068	STEERING HEAD BEARING KOYO SAC3055-1	1
15	81-08045	BEARING LIP SEAL OVERMOLDED 55MM OD NOTE: Supersedes part 20-06113	1
16	22-07627	XXM LOWER TRIPLE CLAMP ASSY 15MY IMP NOTE: Superseded by 22-08081	1
17	PA-152	REAR WHEEL SEAL	1
18	24-04437-2	DS/X/MX FRONT FENDER XXM BLACK#1 NOTE: Does not apply to S and SR	1
19	90-02107	WASHER ISO 7093-1 5-200HV ZM-F-01 REV 02 NOTE: Does not apply to S and SR	1
20	90-07292	HEXAGON SOCKET BUTTON HEAD CAP SCREW ISO 7380 M5X16-8.8 ZM-F-11 REV 01 ZM-L-01 REV 01	1
21	90-08015	HEX SOCKET BUTTON HEAD SCREW M8X20 NOTE: Superseded by 90-07516.	1
22	90-02104	WASHER ISO 7089 -8-200 HV ZM-F-01 REV 02	1
23	24-08070	FORK GUARD LEFT	1
24	45-07496	MPI WHEEL SPEED SENSOR	1
25	PA-145	FRONT WHEEL BEARING SPACER	1
26	40-07614	ASSY BATTERY SDS 4-MOD 15MY IMPL NOTE: Superseded by part number 46-08034.	1
27	24-08069	FORK GUARD RIGHT	1
28	23-07491	HOLLOW AXLE FRONT	1

29	22-05878	DS FORK 41MM RIGHT	1
30	22-05877	DS FORK 41MM LEFT	1

ZEV0025 - Body Trim

Callout	Part Number	Part Name	Qty. per Motorcycle
1	20-06677	XXM HEADLIGHT MOUNT RIGHT SIDE	1
2	20-06678	XXM HEADLIGHT MOUNT LEFT SIDE	1
3	20-03066	RIVET PUSH PUSH NYLON M6	1
4	24-05058-2	FAIRING FRONT RIGHT POLYPROPYLENE BLACK 13MY IMP	1
5	90-04085	WASHER M5 X 11 X 1 NYLON 6/6 BLACK	1
6	90-04084	HEXAGON SOCKET BUTTON HEAD CAP SCREW ISO 7380 M5X16-8.8 ZM-F-11 REV 03	1
7	24-07567	XXM TOP CENTER CONSOLE WITH MACHINE FEATURE TO CLEAR GUSSET	1
8	90-02140	CLIP-ON U-NUT M5X15.8DP	1
9	90-02101	HEADLIGHT MOUNTING WASHER	1
10	90-07285	HEXAGON FLANGE BOLT DIN 6921 OR ISO 4162 M5X16 ZM-F-01 REV 03 ZM-L-01 REV 01	1
11	90-04084	HEXAGON SOCKET BUTTON HEAD CAP SCREW ISO 7380 M5X16-8.8 ZM-F-11 REV 03	1
12	90-04085	WASHER M5 X 11 X 1 NYLON 6/6 BLACK	1
13	24-05059-2	FAIRING FRONT LEFT POLYPROPYLENE BLACK 13MY IMP	1
14	20-03066	RIVET PUSH PUSH NYLON M6	1
15	90-04084	HEXAGON SOCKET BUTTON HEAD CAP SCREW ISO 7380 M5X16-8.8 ZM-F-11 REV 03	1
16	90-04085	WASHER M5 X 11 X 1 NYLON 6/6 BLACK	1
17	24-03873-1	REAR NUMBER PLATE RIGHT SIDE BLACK#2	1
18	90-07284	HEX FLANGE BOLT M8X25	1
19	90-02053	PREVAILING TORQUE TYPE NUT DIN 985 M5-08 ZM-F-01 REV 02	1
20	90-02101	HEADLIGHT MOUNTING WASHER	1
21	24-06001	XXM SEAT	1
22	90-02053	PREVAILING TORQUE TYPE NUT DIN 985 M5-08 ZM-F-01 REV 02	1
23	90-02101	HEADLIGHT MOUNTING WASHER	1
24	24-04449-1	XXM BODY TAIL PP BLACK#2	1
25	24-05285	XXM REFLECTOR MOUNT BRACKET	1
26	90-05244	HEXAGON SOCKET COUNTERSUNK HEAD SCREW ISO 10642 M5X12-10.9 ZM-F-01 REV 03	1
27	90-05244	HEXAGON SOCKET COUNTERSUNK HEAD SCREW ISO 10642 M5X12-10.9 ZM-F-01 REV 03	1
28	24-05160	LICENSE PLATE BRACKET NOTE: ONLY USED ON EU/ AUSTRALIA/ UK REGIONS	1
29	90-02101	HEADLIGHT MOUNTING WASHER	1
30	90-02053	PREVAILING TORQUE TYPE NUT DIN 985 M5-08 ZM-F-01 REV 02	1

31	90-02101	HEADLIGHT MOUNTING WASHER	1
32	90-02053	PREVAILING TORQUE TYPE NUT DIN 985 M5-08 ZM-F-01 REV 02	1
33	90-05887	PHILIPS HEAD SHEET METAL SCREW 10 X 1/2	1
34	90-05887	PHILIPS HEAD SHEET METAL SCREW 10 X 1/2	1
35	24-04451	X/MX TAIL POD	1
36	90-02610	HEXAGON FLANGE BOLT DIN 6921 OR ISO 4162 M5X20 ZM-F-01 REV 02	1
37	90-02610	HEXAGON FLANGE BOLT DIN 6921 OR ISO 4162 M5X20 ZM-F-01 REV 02	1
38	90-04084	HEXAGON SOCKET BUTTON HEAD CAP SCREW ISO 7380 M5X16-8.8 ZM-F-11 REV 03	1
39	90-04085	WASHER M5 X 11 X 1 NYLON 6/6 BLACK	1
40	24-08157	REAR INNER FENDER NOTE: Supersedes part number 24-04438	1
41	90-04084	HEXAGON SOCKET BUTTON HEAD CAP SCREW ISO 7380 M5X16-8.8 ZM-F-11 REV 03	1
42	90-04085	WASHER M5 X 11 X 1 NYLON 6/6 BLACK	1
43	90-07284	HEX FLANGE BOLT M8X25	1
44	90-04084	HEXAGON SOCKET BUTTON HEAD CAP SCREW ISO 7380 M5X16-8.8 ZM-F-11 REV 03	1
45	90-04085	WASHER M5 X 11 X 1 NYLON 6/6 BLACK	1
46	24-03874-1	REAR NUMBER PLATE LEFT SIDE BLACK#2	1
47	24-06190	XMX CONTROLLER COVER L 14MY IMPL	1
48	90-03113	XMAS TREE CLIP .25" X .39" LG X .70" HD	1
49	90-04084	HEXAGON SOCKET BUTTON HEAD CAP SCREW ISO 7380 M5X16-8.8 ZM-F-11 REV 03	1
50	90-04085	WASHER M5 X 11 X 1 NYLON 6/6 BLACK	1
51	90-04084	HEXAGON SOCKET BUTTON HEAD CAP SCREW ISO 7380 M5X16-8.8 ZM-F-11 REV 03	1
52	90-04085	WASHER M5 X 11 X 1 NYLON 6/6 BLACK	1
53	90-02140	CLIP-ON U-NUT M5X15.8DP	1
54	20-03066	RIVET PUSH PUSH NYLON M6	1
55	24-06191	XMX CONTROLLER COVER R 14MY IMPL	1
56	90-04085	WASHER M5 X 11 X 1 NYLON 6/6 BLACK	1
57	90-04084	HEXAGON SOCKET BUTTON HEAD CAP SCREW ISO 7380 M5X16-8.8 ZM-F-11 REV 03	1
58	24-06043	XMX FAIRING CENTER	1
59	90-07292	HEXAGON SOCKET BUTTON HEAD CAP SCREW ISO 7380 M5X16-8.8 ZM-F-11 REV 01 ZM-L-01 REV 01	1
60	24-08070	FORK GUARD LEFT	1
61	90-04085	WASHER M5 X 11 X 1 NYLON 6/6 BLACK	1
62	24-04437-2	DS/X/MX FRONT FENDER XMX BLACK#1 NOTE: Does not apply to S and SR	1
63	90-02107	WASHER ISO 7093-1 5-200HV ZM-F-01 REV 02 NOTE: Does not apply to S and SR	1

64	90-07292	HEXAGON SOCKET BUTTON HEAD CAP SCREW ISO 7380 M5X16-8.8 ZM-F-11 REV 01 ZM-L-01 REV 01	1
65	90-02140	CLIP-ON U-NUT M5X15.8DP	1
66	90-04085	WASHER M5 X 11 X 1 NYLON 6/6 BLACK	1
67	90-04084	HEXAGON SOCKET BUTTON HEAD CAP SCREW ISO 7380 M5X16-8.8 ZM-F-11 REV 03	1
68	24-07673	SHORT NOSE DUAL BEAM FLY-SCREEN	1
69	90-04085	WASHER M5 X 11 X 1 NYLON 6/6 BLACK	1
70	90-04084	HEXAGON SOCKET BUTTON HEAD CAP SCREW ISO 7380 M5X16-8.8 ZM-F-11 REV 03	1
71	90-07265	HEXAGON SOCKET HEAD CAP SCREW ISO 4762 M6X20-8.8 ZM-F-01 REV 03 ZM-L-01 REV 01	1
72	24-02961	MIRROR MOUNT CLAMP	1
73	26-08060	MIRROR LH MOUNT LOW PROFILE NOTE: Bottom part of the mirror mount LH	1
74	27-08006	HAND GRIP THROTTLE SIDE	1
75	27-08057	MIRROR RH NOTE: Supersedes part number 27-08004.	1
76	27-08056	MIRROR LH NOTE: Supersedes part number 27-08003.	1
77	27-08007	HAND GRIP LEFT SIDE	1
78	24-08069	FORK GUARD RIGHT	1
79	27-08002	RIDER INTERFACE MISCELLANEOUS COMPONENT HANDLEBAR END CAP	1
80	27-08002	RIDER INTERFACE MISCELLANEOUS COMPONENT HANDLEBAR END CAP	1

ZEV0026 - Rear Suspension

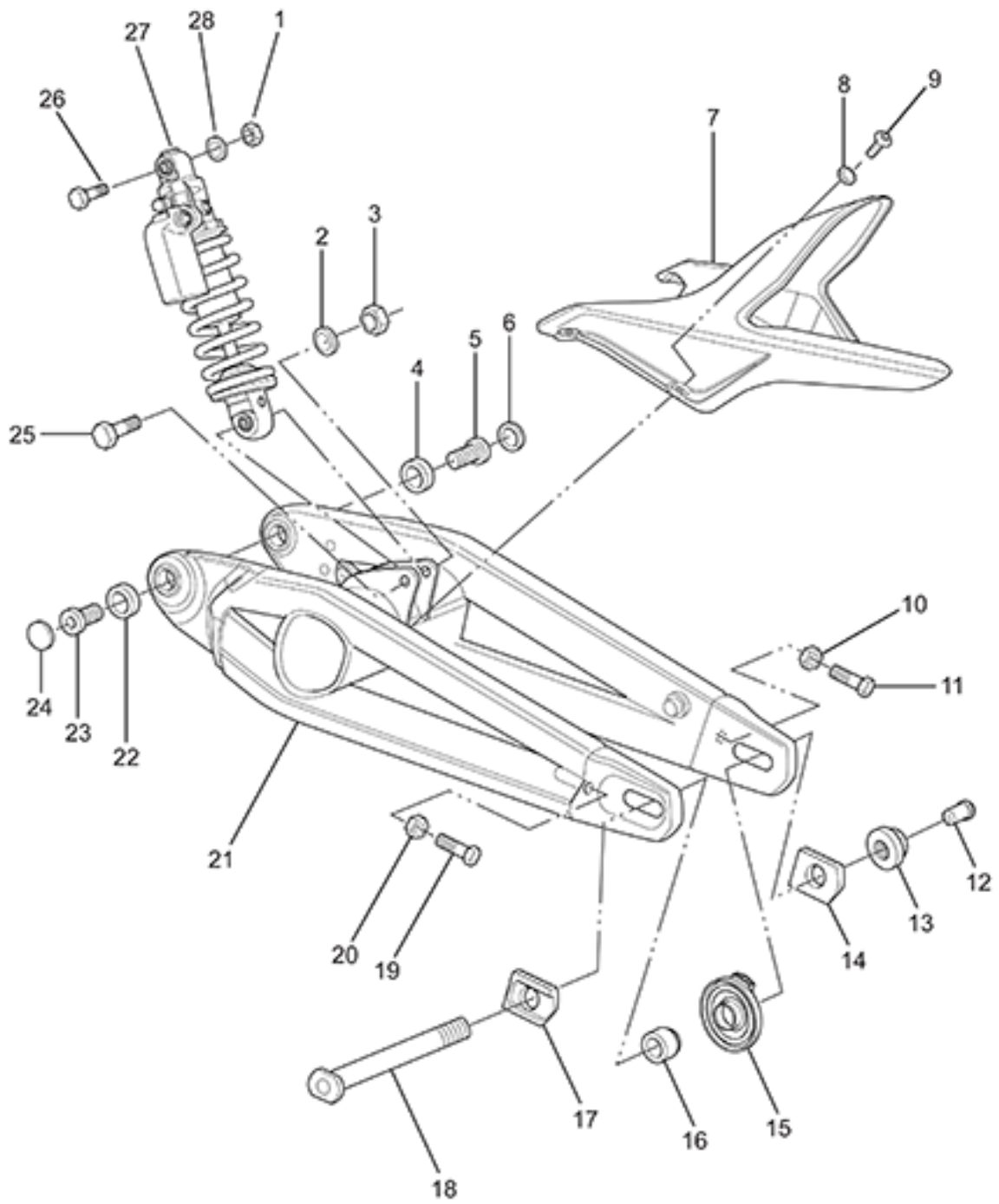

ZEV0026 - Rear Suspension

Callout	Part Number	Part Name	Qty. per Motorcycle
1	90-02050	PREVAILING TORQUE TYPE NUT DIN 985 M10-8 ZM-F-01 REV 02	1
2	90-02100	WASHER ISO 7089 10-200 HV ZM-F-01 REV 02	1
3	90-02050	PREVAILING TORQUE TYPE NUT DIN 985 M10-8 ZM-F-01 REV 02	1
4	20-06138	BEARING 6204 NOTE: Bearing used as swing arm bearing in some models and as the wheel bearing (qty of 5; 2 in front and three in rear wheel) in 2015 and later models. NOTE: Manufacturer part number is 6204-2RS	1
5	20-06130	STUB AXLE	1
6	20-06755	SWINGARM PIVOT BEARING SEAL PROTECTOR	1
7	24-04438	REAR INNER FENDER NOTE: Superseded by 24-08157	1
8	90-04085	WASHER M5 X 11 X 1 NYLON 6/6 BLACK	1
9	90-02109	HEXAGON SOCKET BUTTON HEAD CAP SCREW ISO 7380 M5X12-8.8 ZM-F-01 REV 03	1
10	90-05088	HEXAGON FLANGE NUT DIN 6923 M8-1.25 ZM-F-01 REV 03	1
11	90-03030	HEXAGON HEAD SCREW DIN 933 M8X40-10.9 ZM-F-01 REV 03	1
12	<i>Not Applicable to this Bike Model</i>		
13	90-05678	U-NUT M20X1.5 FN 27S 15H (REAR AXLE NUT) NOTE: Rear Axle Nut	1
14	20-04738	REAR AXLE ADJUSTER PUSH BLOCK, NUT SIDE	1
15	45-07496	MPI WHEEL SPEED SENSOR	1
16	23-07489	WHEEL SPACER DRIVE SIDE REAR	1
17	20-04737	REAR AXLE ADJUSTER PUSH BLOCK, HEAD SIDE	1
18	23-04736	AXLE 20MM HOLLOW NOTE: Superseded by pn:23-08032	1
19	90-03030	HEXAGON HEAD SCREW DIN 933 M8X40-10.9 ZM-F-01 REV 03	1
20	90-05088	HEXAGON FLANGE NUT DIN 6923 M8-1.25 ZM-F-01 REV 03	1
21	21-07748	X SWINGARM NOTE: Superseded by part number 26-08068.	1
22	20-06138	BEARING 6204 NOTE: Bearing used as swing arm bearing in some models and as the wheel bearing (qty of 5; 2 in front and three in rear wheel) in 2015 and later models. NOTE: Manufacturer part number is 6204-2RS	1
23	20-06130	STUB AXLE	1

24	20-06755	SWINGARM PIVOT BEARING SEAL PROTECTOR	1
25	90-05711	LOWER SHOCK EYE BOLT M10-1.5X60MM	1
26	90-05711	LOWER SHOCK EYE BOLT M10-1.5X60MM	1
27	22-05879	FX SHOCK 40MM	1
28	90-02100	WASHER ISO 7089 10-200 HV ZM-F-01 REV 02	1

ZEV0027 - Frame (Left)

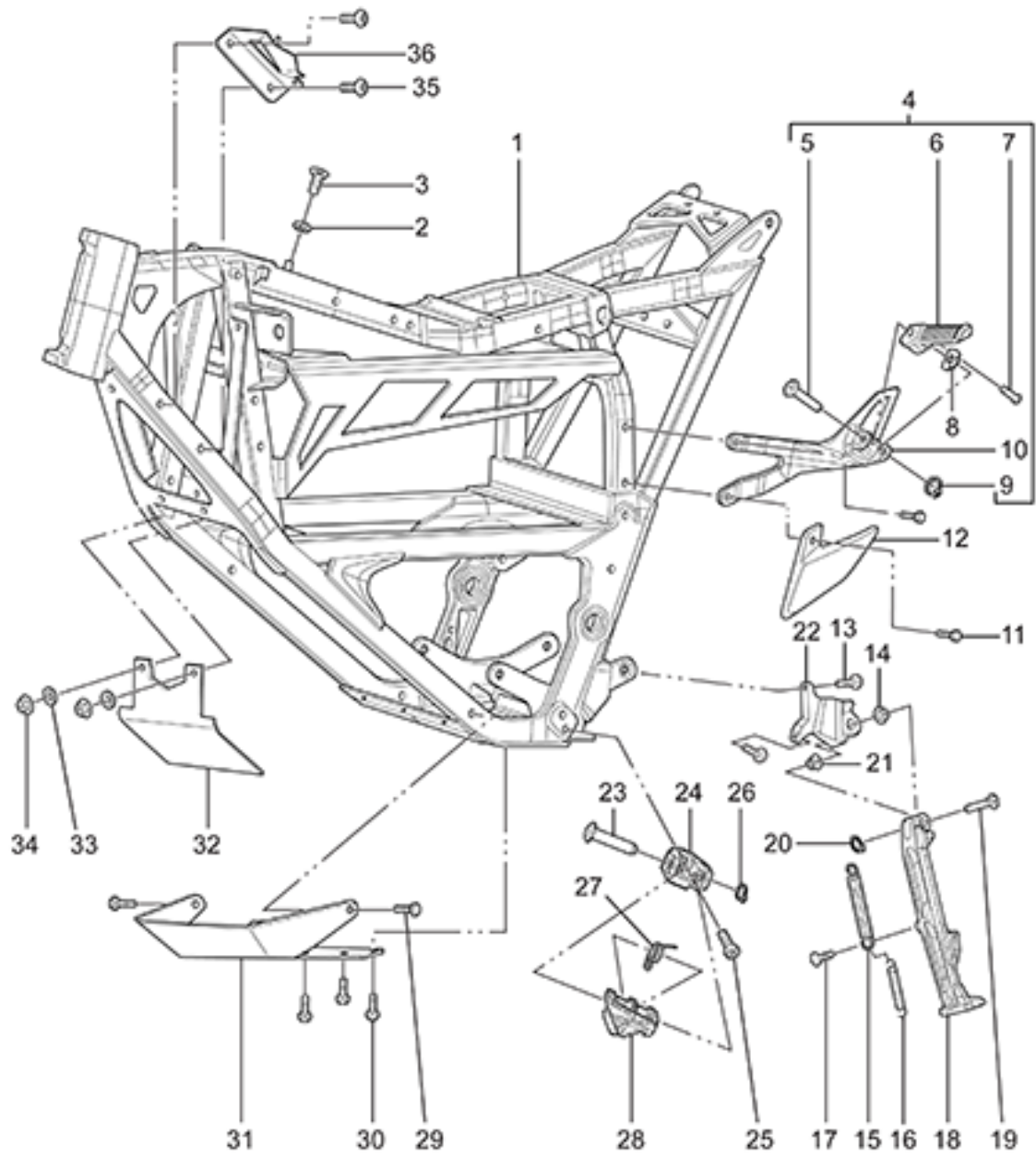

ZEV0027 - Frame (Left)

Callout	Part Number	Part Name	Qty. per Motorcycle
1	26-08080	FRAME XMX COMPLETE ASSEMBLY WITH RAIL AND BEARINGS NOTE: Must supply VIN# and Warranty Claim# when ordering. NOTE: Supersedes part number 20-07479.	1
2	20-06439	SEAT KNOB 14MY IMPL	1
3	90-02059	HEXAGON SOCKET COUNTERSUNK HEAD SCREW ISO 10642 M6X18-8.8 ZM-F-01 REV 03	1
4	10-07417	PASSENGER PEGS KIT - 2014 FX NOTE: Take a friend for a ride on your 2014 Zero FX. With the passenger pegs kit, they will have a comfortable place for their feet as you introduce them to the thrilling acceleration of your motorcycle. NOTE: 2014 [Zero FX]	1

Part Detail for #4. PASSENGER PEGS KIT - 2014 FX

Callout	Part Number	Part Name	Qty. per Motorcycle
5	90-02725	CLEVIS PIN CUSTOM 10MM X 45L	1
6	27-08039	PASSENGER FOOTPEG LEFT SIDE	1
7	20-05404	FOOTPEG DETENT BALL MECHANISM	1
8	20-04279	FOOTPEG DETENT PLATE	1
9	90-02879	RETAINING RING 9MM SHAFT	1
10	20-04285	SDS PASSENGER PEG BRKT L	1

11	90-07284	HEX FLANGE BOLT M8X25	1
12	20-06939	PASSENGER PEG BRACKET HEEL GUARD LEFT NOTE: USED ONLY ON EU FX	1
13	90-07277	HEXAGON SOCKET THIN HEAD CAP SCREW DIN 7984 M10X25-8.8 ZM-F-01 REV 03 ZM-L-01 REV 01	1
14	90-02800	BUSHING FLANGE 0.375	1
15	20-00710	S KS SPRING OUT	1
16	20-00709	S KS SPRING IN	1
17	90-07261	HEXAGON SOCKET COUNTERSUNK HEAD SCREW ISO 10642 M8X20-10.9 ZM-F-01 REV 03 ZM-L-01 REV 01	1
18	26-08099	SIDESTAND MEDIUM-LONG ASSY W/MAGNET	1
19	90-02799	CLEVIS PIN CUSTOM NOTE: Used to attach kickstand leg to mount.	1
20	90-02837	E CLIP 0.375	1
21	90-02800	BUSHING FLANGE 0.375	1
22	20-06590	KICKSTAND MOUNT	1
23	90-02725	CLEVIS PIN CUSTOM 10MM X 45L	1

24	20-02723	CLEVIS FOOT PEG UNIVERSAL LEFT	1
25	90-07277	HEXAGON SOCKET THIN HEAD CAP SCREW DIN 7984 M10X25-8.8 ZM-F-01 REV 03 ZM-L-01 REV 01	1
26	90-02879	RETAINING RING 9MM SHAFT	1
27	20-02727	TORSION SPRING, .678 OD .078 WIRE, CCW	1
28	20-02548	FOOTPEG, LEFT	1
29	90-07269	HEXAGON SOCKET HEAD CAP SCREW ISO 4762 M8X30-10.9 ZM-F-01 REV 03 ZM-L-01 REV 01	1
30	90-07269	HEXAGON SOCKET HEAD CAP SCREW ISO 4762 M8X30-10.9 ZM-F-01 REV 03 ZM-L-01 REV 01	1
31	26-08018	XMV SKID PLATE HEAT SINK PROTECTION	1
32	20-05036	HEAT SINK MOUNT	1
33	90-02103	WASHER ISO 7089 6-200HV ZM-F-01 REV 02	1
34	90-02053	PREVAILING TORQUE TYPE NUT DIN 985 M5-08 ZM-F-01 REV 02	1
35	90-04084	HEXAGON SOCKET BUTTON HEAD CAP SCREW ISO 7380 M5X16-8.8 ZM-F-11 REV 03	1
36	26-08041	CHASSIS STRUCTURE MOUNTING BRACKET HORN	1

ZEV0028 - Frame (Right)

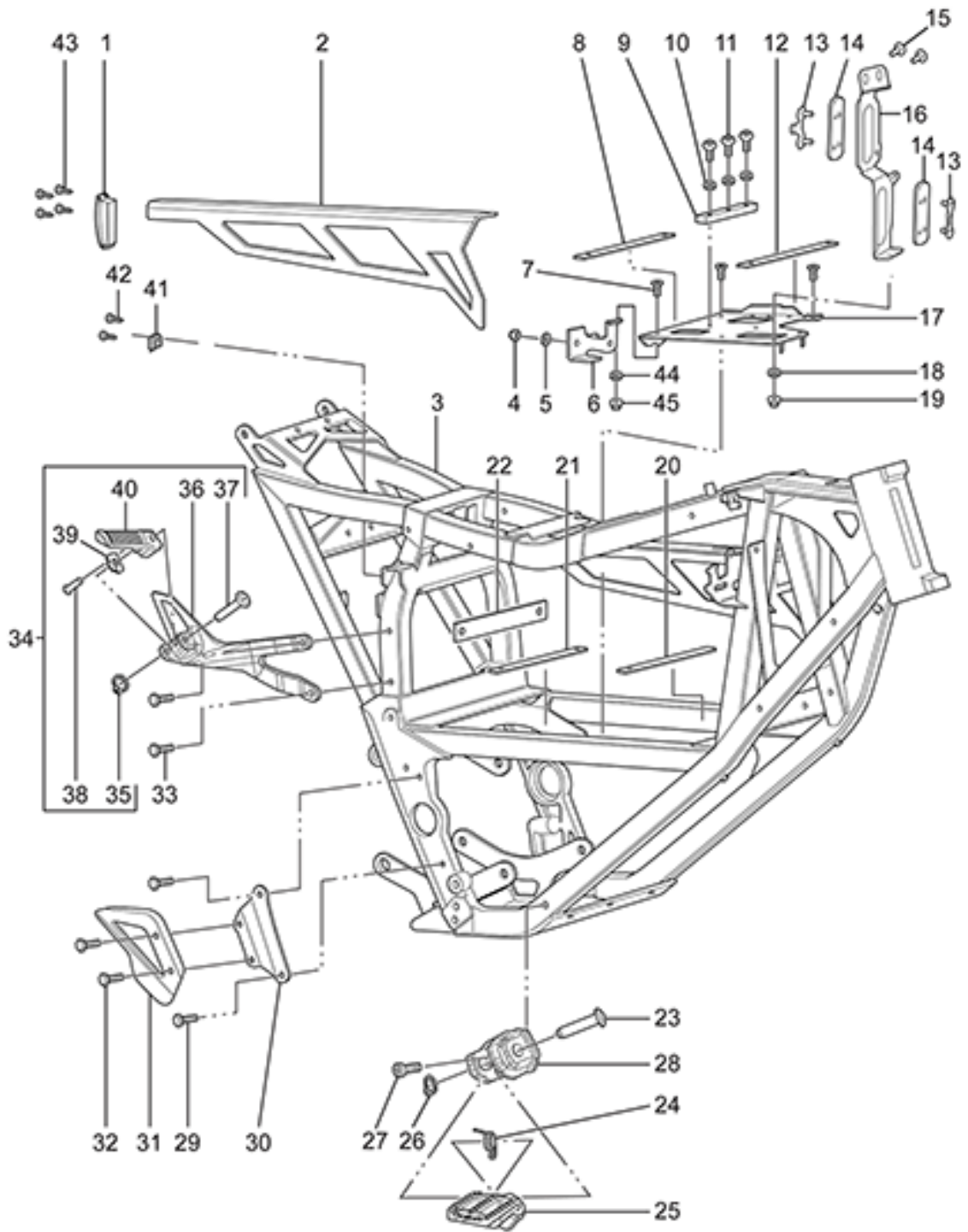

ZEV0028 - Frame (Right)

Callout	Part Number	Part Name	Qty. per Motorcycle
1	20-05296	PANEL MOUNT LATCH LOCKING C9101-2112	1
2	20-06404	<p>XXM BATTERY RETAINING RAIL</p> <p>NOTE: Rail does not include latch (20-05296), screws (90-06857), foam or ZF insignia, which are ordered separately.</p>	1
3	26-08080	<p>FRAME XXM COMPLETE ASSEMBLY WITH RAIL AND BEARINGS</p> <p>NOTE: Must supply VIN# and Warranty Claim# when ordering.</p> <p>NOTE: Supersedes part number 20-07479.</p>	1
4	90-02053	PREVAILING TORQUE TYPE NUT DIN 985 M5-08 ZM-F-01 REV 02	1
5	90-02103	WASHER ISO 7089 6-200HV ZM-F-01 REV 02	1
6	20-06862	MOUNT BRACKET AUX CHARGE XXM	1
7	90-05244	HEXAGON SOCKET COUNTERSUNK HEAD SCREW ISO 10642 M5X12-10.9 ZM-F-01 REV 03	1
8	20-05773	MODULE SLIDER GENERAL	1
9	20-05153	MODULE SEPERATOR BLOCK	1
10	90-02101	HEADLIGHT MOUNTING WASHER	1
11	90-02119	HEXAGON SOCKET BUTTON HEAD CAP SCREW M5X8-8.8	1
12	20-05774	MODULE SLIDER FRONT MODULE HORIZONTALS	1
13	20-05286	COMPLIANT MOUNT RETAINER AND NUT PLATE	1
14	20-05109	BIKE SIDE COMPLIANT MODULE CONNECTOR MOUNT	1
15	PA-155	CAD PART NUMBER 90-02614	1
16	20-05912	BIKE SIDE MODULE CONNECTOR HOLDER COMPLIANT MOUNT	1
17	20-06863	XXM MODULE SUPPORT PLATFORM 14MY IMPL	1
18	90-02103	WASHER ISO 7089 6-200HV ZM-F-01 REV 02	1
19	90-02054	PREVAILING TORQUE TYPE NUT DIN 985 M6-8 ZM-F-01 REV 02	1
20	20-05774	MODULE SLIDER FRONT MODULE HORIZONTALS	1
21	20-05773	MODULE SLIDER GENERAL	1
22	20-05773	MODULE SLIDER GENERAL	1
23	90-02725	CLEVIS PIN CUSTOM 10MM X 45L	1
24	20-02727	TORSION SPRING, .678 OD .078 WIRE, CCW	1
25	20-02549	<p>FOOTPEG, RIGHT</p> <p>NOTE: Does not apply to S and SR</p>	1
26	90-02879	RETAINING RING 9MM SHAFT	1
27	90-07277	HEXAGON SOCKET THIN HEAD CAP SCREW DIN 7984 M10X25-8.8 ZM-F-01 REV 03 ZM-L-01 REV 01	1
28	20-02724	CLEVIS FOOT PEG UNIVERSAL RIGHT	1
29	90-07268	HEXAGON SOCKET HEAD CAP SCREW ISO 4762 M8X25-10.9 ZM-F-01 REV 03 ZM-L-01 REV 01	1

30	20-06295	REAR MASTER CYLINDER BRACKET XMX M6 THRU	1
31	20-06939	PASSENGER PEG BRACKET HEEL GUARD LEFT NOTE: USED ONLY ON EU FX	1
32	90-07323	HEXAGON SOCKET BUTTON HEAD CAP SCREW ISO 7380 M6X25-8.8 ZM-F-01 REV 03 ZM-L-01 REV 01	1
33	90-07284	HEX FLANGE BOLT M8X25	1
34	<i>Not Applicable to this Bike Model</i>		
35	<i>Not Applicable to this Bike Model</i>		
36	<i>Not Applicable to this Bike Model</i>		
37	<i>Not Applicable to this Bike Model</i>		
38	<i>Not Applicable to this Bike Model</i>		
39	<i>Not Applicable to this Bike Model</i>		
40	<i>Not Applicable to this Bike Model</i>		
41	20-05296	PANEL MOUNT LATCH LOCKING C9101-2112	1
42	90-06857	HEXAGON SOCKET COUNTERSUNK HEAD SCREW M3X6	1
43	90-06857	HEXAGON SOCKET COUNTERSUNK HEAD SCREW M3X6	1
44	90-02103	WASHER ISO 7089 6-200HV ZM-F-01 REV 02	1
45	90-02054	PREVAILING TORQUE TYPE NUT DIN 985 M6-8 ZM-F-01 REV 02	1

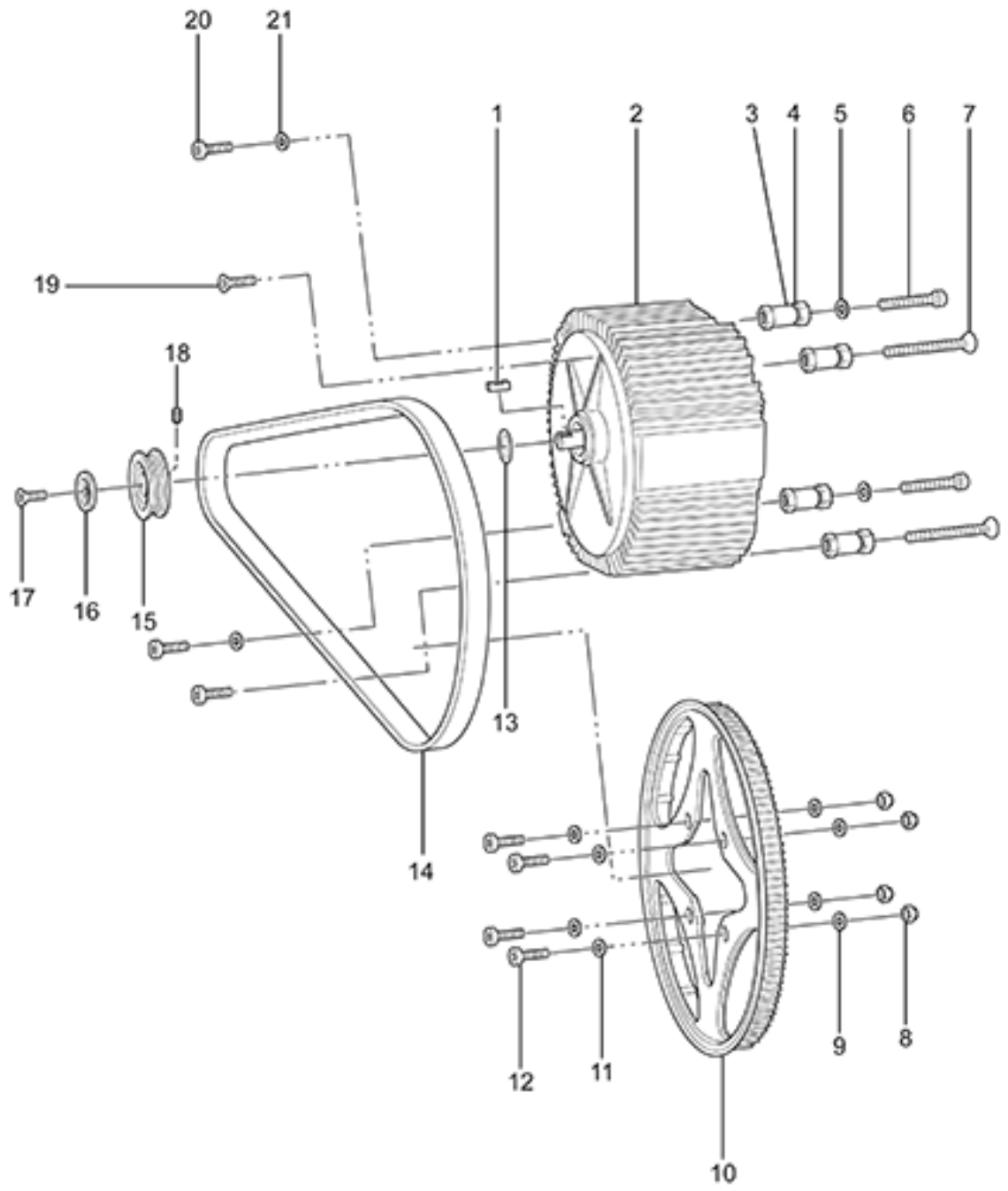

ZEV0029 - Motor and Drive System

Callout	Part Number	Part Name	Qty. per Motorcycle
1	30-06745	SHAFT KEY .25 MOTOR SPROCKET	1
2	12-08041	ZF75-5 IPM 25T MOTOR KIT	1
3	20-04773	MOTOR JACK SCREW OUTER	1
4	20-04774	MOTOR JACK SCREW INNER	1
5	90-02104	WASHER ISO 7089 -8-200 HV ZM-F-01 REV 02	1
6	90-05445	HEXAGON SOCKET HEAD CAP SCREW ISO 4762 M8X80-8.8 ZM-F-01 REV 03	1
7	90-05441	HEXAGON SOCKET COUNTERSUNK HEAD SCREW ISO 10642 M8X80-8.8 ZM-F-01 REV 03	1
8	90-03236	PREVAILING TORQUE TYPE NUT DIN 985 M8-10 ZM-F-01 REV 02	1
9	90-02104	WASHER ISO 7089 -8-200 HV ZM-F-01 REV 02	1
10	30-04051	SPROCKET REAR BELT DRIVE 132T, 8MM PITCH, 17MM WIDE FINISHED	1
11	90-02104	WASHER ISO 7089 -8-200 HV ZM-F-01 REV 02	1
12	90-03248	HEXAGON SOCKET THIN HEAD CAP SCREW M8X30-8REAR SPROCKET	1
13	30-05502	MOTOR SHAFT SPACER 1.5 MM FOR 1" SHAFT	1
14	30-08084	BELT DRIVE, 220T, 8MM PITCH, 14MM WIDE, NEW LOGO	1
15	30-03656	SPROCKET FRONT, BELT DRIVE 25T, 8MM PITCH, 15MM WIDE 1	1
16	20-05453	LOW PROFILE BELT SPROCKET MOTOR SHAFT TOPHAT	1
17	90-02056	HEXAGON SOCKET COUNTERSUNK HEAD SCREW M10X25-8.8 MOTOR SHAFT NOTE: Bolt used to hold front sprocket in place onto the motor shaft.	1
18	90-07298	HEXAGON SOCKET SET SCREW CUP POINT KNURLED ISO 4029 TYPE V M4X6 ZM-F-01 REV 03 ZM-L-01 REV 01 NOTE: 2 set screws are needed for an SR motor.	1
19	90-08037	HEXALOBULAR (6 LOBE) SOCKET FLAT HEAD COUNTERSUNK SCREW ISO 14582 M8X30-10.9 ZM-F-01 REV 04 NOTE: Used for both drive side rear motor mount or rear sprocket mounting depending on model. NOTE: Supersedes 90-03223.	1
20	90-02096	MOTOR MOUNTING LEFT FRONT TOP AND LEFT FRONT BOTTOM BOLT	1
21	90-02104	WASHER ISO 7089 -8-200 HV ZM-F-01 REV 02	1

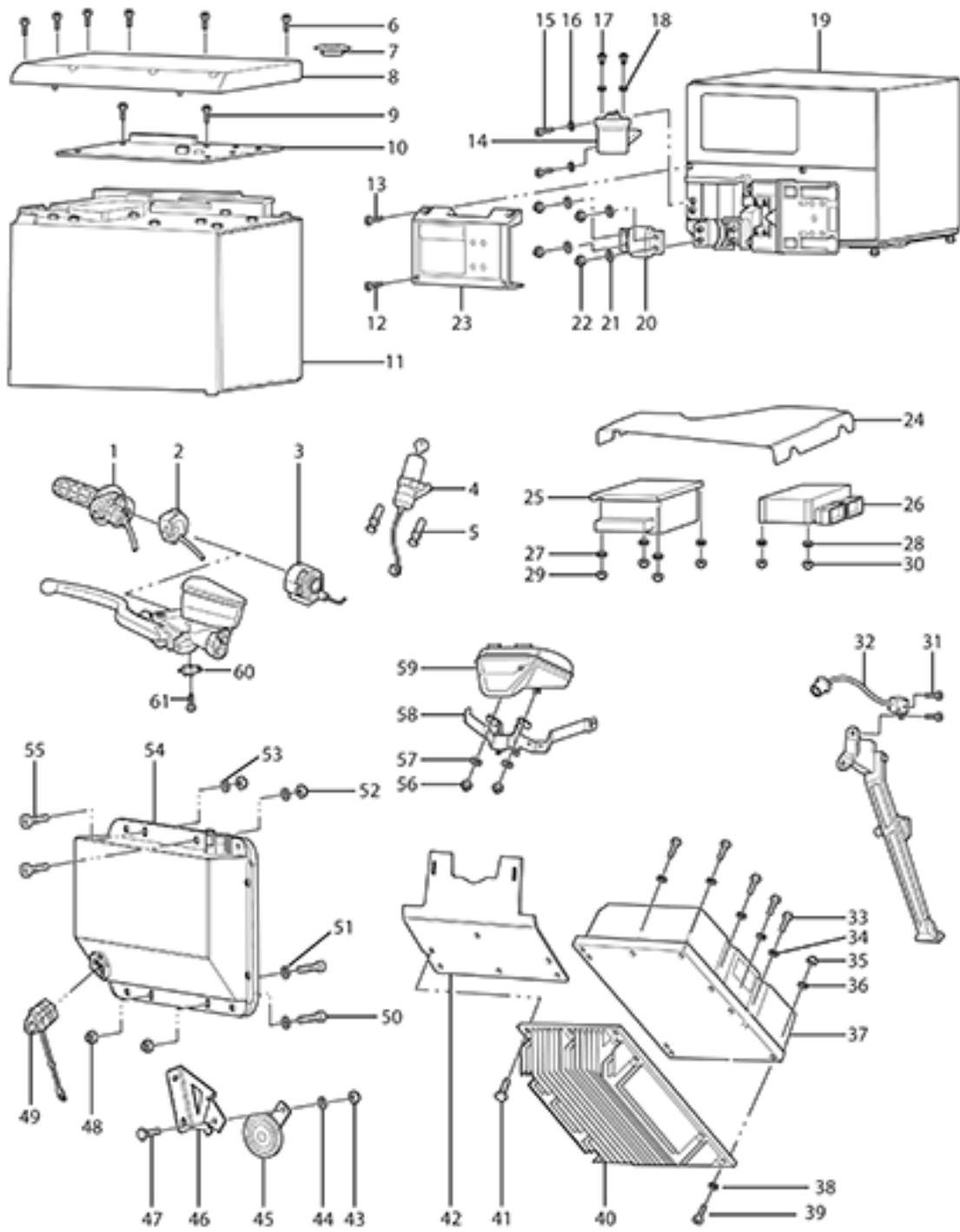

Callout	Part Number	Part Name	Qty. per Motorcycle
1	45-08039	THROTTLE BITRON HALL EFFECT PCB NOTE: Replaced PN 27-08000	1
2	40-06054	KILL MODE START SWITCH	1
3	60-07780	LEFT HAND SWITCHGEAR ECIE	1
4	45-02692	KEYSWITCH LOCK ZADI, IGNITION SWITCH NOTE: This part is the ignition switch and keys only. If you want a matching helmet lock for 16MY motorcycles and older, please order p/n 20-05202. If you want the key switch and a lock for a tank trunk, please order 27-08030. If you want a ignition and matching locks for tank trunk and storage trunks, please order part number 27-08044.	1
5	90-02937	M8X14MM BREAK AWAY HEX BOLT NOTE: One Time Use Bolt	1
6	90-07126	HEXAGON SOCKET HEAD CAP SCREW ISO 4762 M4X8-8.8 ZM-F-01 REV 03 ZM-L-02 REV 01	1
7	20-04094	PLUG DIAG PORT 24.50 THRU 26.00 MM 12MY IMPL	1
8	20-06197	MODULE BMS COVER 14 MY IMPL	1
9	PA-160	M4 X 6MM X HEX HEAD BOLT	1
10	40-08031	BMS PCB ASSY POTTED 17MY IMPL NOTE: PLEASE INCLUDE VIN# OF BIKE AND BATTERY SERIAL # FOR PROGRAMMING PURPOSES NOTE: FOR FX/FXP, IF BATTERY SERIAL NUMBER STARTS WITH 14SG**** PLEASE ORDER 41-06419 NOTE: Super seeded pn:40-07232	1
11	46-08032	ZF3.3 POWER PACK MODULE (2014-2016) NOTE: Z-Force® power pack technology has been revolutionizing the electric motorcycle industry since 2007 when the first Zeros started rolling out of the Santa Cruz factory. The goal: pack more energy into less space. Using state-of-the-art lithium-ion cell chemistry and advanced battery management systems, the ZF3.3 Power Pack Module offers incredible power density and versatility. Zero Motorcycles is the first electric motorcycle manufacturer to feature hot-swappable modules. The Zero FX and Zero FXS can be ridden using either one or two ZF3.3 modules. Modules can be moved between compatible motorcycles quickly, without concern regarding the state-of-charge or relative age of the accompanying module. NOTE: 2014-2016 [Zero FX, FXS, MMX] - VIN# or Warranty Claim Number Must Be Provided At Time Of Order To Be Covered Under Warranty.	1

12	90-07128	HEXAGON SOCKET HEAD CAP SCREW ISO 4762 M4X35-8.8 ZM-F-01 REV 03 ZM-L-02 REV 01	1
13	90-07126	HEXAGON SOCKET HEAD CAP SCREW ISO 4762 M4X8-8.8 ZM-F-01 REV 03 ZM-L-02 REV 01	1
14	45-08135	CONTACTOR W HEX MODIFIED KCS01 SIDE MOUNT NOTE: Contactor / Current Sensor for modular power pack NOTE: Not for monolith	1
15	90-07123	HEXAGON SOCKET HEAD CAP SCREW ISO 4762 M4X16-8.8 ZM-F-01 REV 03 ZM-L-02 REV 01	1
16	90-07123	HEXAGON SOCKET HEAD CAP SCREW ISO 4762 M4X16-8.8 ZM-F-01 REV 03 ZM-L-02 REV 01	1
17	PA-168	CONTACTOR TERMINAL BOLT	1
18	PA-169	CONTACTOR TERMINAL BOLT WASHER	1
19	46-08032	ZF3.3 POWER PACK MODULE (2014-2016) NOTE: Z-Force® power pack technology has been revolutionizing the electric motorcycle industry since 2007 when the first Zeros started rolling out of the Santa Cruz factory. The goal: pack more energy into less space. Using state-of-the-art lithium-ion cell chemistry and advanced battery management systems, the ZF3.3 Power Pack Module offers incredible power density and versatility. Zero Motorcycles is the first electric motorcycle manufacturer to feature hot-swappable modules. The Zero FX and Zero FXS can be ridden using either one or two ZF3.3 modules. Modules can be moved between compatible motorcycles quickly, without concern regarding the state-of-charge or relative age of the accompanying module. NOTE: 2014-2016 [Zero FX, FXS, MMX] - VIN# or Warranty Claim Number Must Be Provided At Time Of Order To Be Covered Under Warranty.	1
20	45-06195	FUSE 300A 170VDC 4 HOLD MODIFIED CLASS T	1
21	90-02102	WASHER UNIVERSAL (SIZE 1)	1
22	90-02052	MBB TO FRAME FRONT	1
23	80-08029	MODULE FUSE COVER ZF3.3	1
24	24-05783	XMV CONTROLLER FORMEX TOP	1
25	60-07190	DC-DC CONV 500W SEVCON 622-11211 ABS UNITS	1
26	40-07671	ASSY MBB GENERIC 15MY IMPL NOTE: NOTE: Need to provide motorcycle VIN in shipping notes.	1
27	90-02102	WASHER UNIVERSAL (SIZE 1)	1
28	90-02102	WASHER UNIVERSAL (SIZE 1)	1
29	90-02052	MBB TO FRAME FRONT	1
30	90-02052	MBB TO FRAME FRONT	1
31	90-07130	HEXAGON SOCKET HEAD CAP SCREW ISO 4762 M4X10-8.8 ZM-F-01 REV 03 ZM-L-01 REV 01	1
32	45-02413	HALL SENSOR SIDESTAND SWITCH	1
33	90-02092	SIZE 4 CONTROLLER BOLTS	1

34	90-02104	WASHER ISO 7089 -8-200 HV ZM-F-01 REV 02	1
35	PA-174	BOLT	1
36	90-02103	WASHER ISO 7089 6-200HV ZM-F-01 REV 02	1
37	60-07007	CONTROLLER SIZE 4 GEN 4 SEVCON NOTE: PLEASE INCLUDE VIN# OF BIKE FOR PROGRAMMING PURPOSES	1
38	90-02103	WASHER ISO 7089 6-200HV ZM-F-01 REV 02	1
39	90-02092	SIZE 4 CONTROLLER BOLTS	1
40	20-06553	XMX HEATSINK MY14	1
41	90-07269	HEXAGON SOCKET HEAD CAP SCREW ISO 4762 M8X30-10.9 ZM-F-01 REV 03 ZM-L-01 REV 01	1
42	20-05036	HEAT SINK MOUNT	1
43	90-02071	HEXAGON NUT ISO 4032 M6-8 ZM-F-01 REV 02	1
44	90-02103	WASHER ISO 7089 6-200HV ZM-F-01 REV 02	1
45	45-06774	DISC HORN K70/H12 V WITH BLACK ZINC	1
46	26-08041	CHASSIS STRUCTURE MOUNTING BRACKET HORN	1
47	90-07285	HEXAGON FLANGE BOLT DIN 6921 OR ISO 4162 M5X16 ZM-F-01 REV 03 ZM-L-01 REV 01	1
48	90-02071	HEXAGON NUT ISO 4032 M6-8 ZM-F-01 REV 02	1
49	45-04864	CAVITY PLUG C13	1
50	90-07265	HEXAGON SOCKET HEAD CAP SCREW ISO 4762 M6X20-8.8 ZM-F-01 REV 03 ZM-L-01 REV 01	1
51	90-02103	WASHER ISO 7089 6-200HV ZM-F-01 REV 02	1
52	90-02071	HEXAGON NUT ISO 4032 M6-8 ZM-F-01 REV 02	1
53	45-04864	CAVITY PLUG C13	1
54	40-08089	CALEX CHARGER ASSEMBLY 720W REG 10.5 EMC COMPLIANT NOTE: Supersedes part number 40-07488.	1
55	90-07265	HEXAGON SOCKET HEAD CAP SCREW ISO 4762 M6X20-8.8 ZM-F-01 REV 03 ZM-L-01 REV 01	1
56	90-02054	PREVAILING TORQUE TYPE NUT DIN 985 M6-8 ZM-F-01 REV 02	1
57	90-02103	WASHER ISO 7089 6-200HV ZM-F-01 REV 02	1
58	PA-227	DASH SUPPORT BRACKET STEEL	1
59	40-08030	DASH LCD (ABS) BUG LOGO NOTE: Applicable 14MY-16MY	1
60	PA-119	BRAKE SWITCH NOTE: Not sold separately. Please order the Master Cylinder.	1
61	PA-61	BRAKE SWITCH SCREW	1

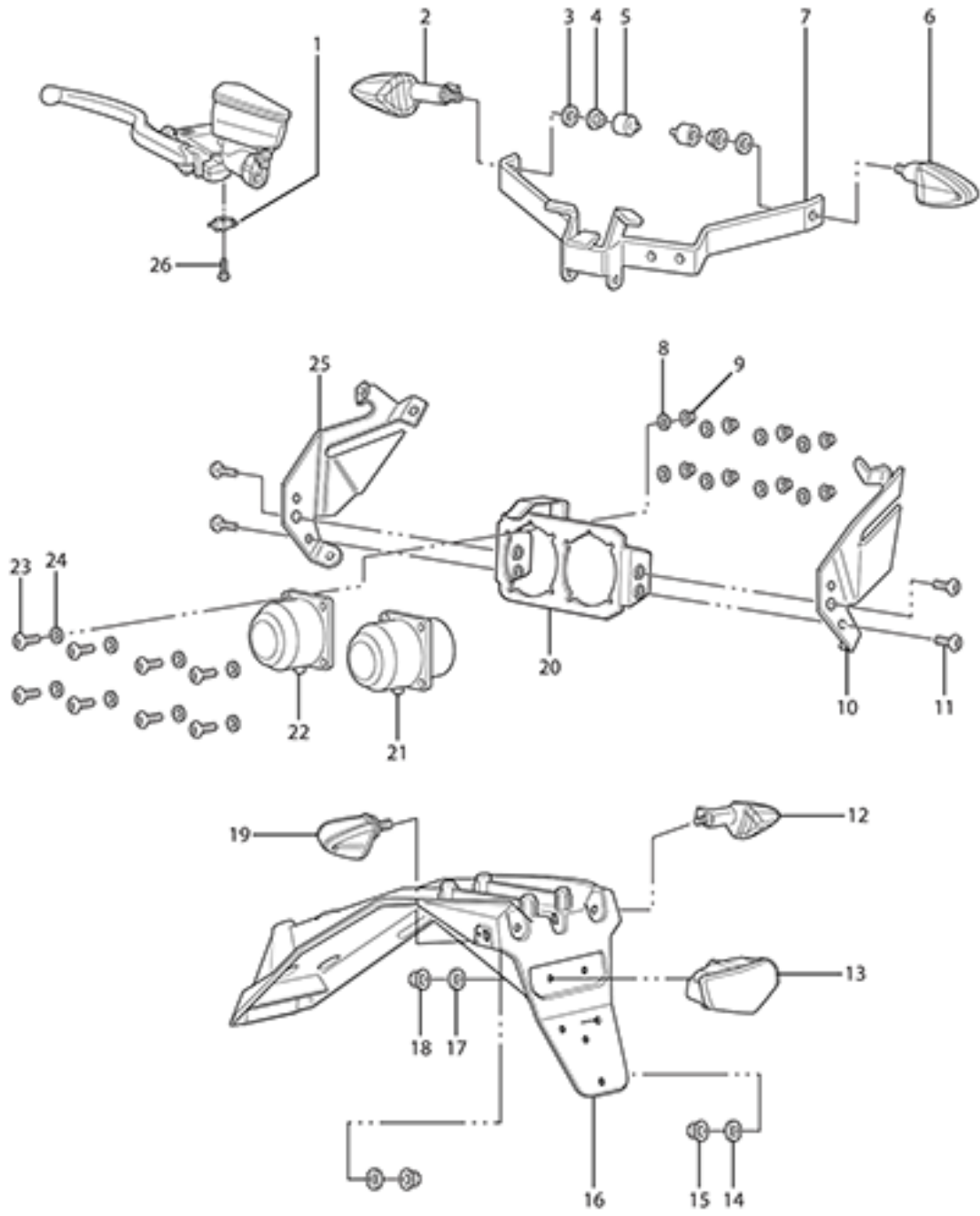

ZEV0021 - Lighting

Callout	Part Number	Part Name	Qty. per Motorcycle
1	PA-119	BRAKE SWITCH NOTE: Not sold separately. Please order the Master Cylinder.	1
2	65-03462	TURN SIGNAL FR-RH RR-LH	1
3	90-02043	TOOTHED LOCK WASHER WITH EXTERNAL TEETH DIN 6797 A M10-B85 ZM-F-01 REV 02	2
4	90-02072	HEXAGON THIN NUT ISO 4035 M10-04 ZM-F-01 REV 02	2
5	20-03146	TURN SIGNAL HEX NUT CAP	2
6	65-03463	TURN SIGNAL FR-LH RR-RH	1
7	PA-227	DASH SUPPORT BRACKET STEEL	1
8	10-06422	GIVI VISION TOP CASE GLOSS BLACK NOTE: Superseded by 24-08402.	1
9	10-06422	GIVI VISION TOP CASE GLOSS BLACK NOTE: Superseded by 24-08402.	1
10	20-06678	XXM HEADLIGHT MOUNT LEFT SIDE	1
11	90-02414	HEXAGON SOCKET BUTTON HEAD SCREW ISO 7380 M8X12-8.8 ZM-F-01 REV 03	4
12	65-03463	TURN SIGNAL FR-LH RR-RH	1
13	65-00600	TAIL LIGHT	1
14	90-02043	TOOTHED LOCK WASHER WITH EXTERNAL TEETH DIN 6797 A M10-B85 ZM-F-01 REV 02	2
15	90-02072	HEXAGON THIN NUT ISO 4035 M10-04 ZM-F-01 REV 02	2
16	24-04451	X/MX TAIL POD	1
17	90-02103	WASHER ISO 7089 6-200HV ZM-F-01 REV 02	10
18	90-02071	HEXAGON NUT ISO 4032 M6-8 ZM-F-01 REV 02	1
19	65-03462	TURN SIGNAL FR-RH RR-LH	1
20	20-06042	HEADLIGHT PIVOT BRACKET	1
21	65-06401	14MY XXM HEADLIGHT LOW BEAM	1
22	65-06400	14MY XXM HEADLIGHT HIGH BEAM	1
23	10-06422	GIVI VISION TOP CASE GLOSS BLACK NOTE: Superseded by 24-08402.	1
24	10-06422	GIVI VISION TOP CASE GLOSS BLACK NOTE: Superseded by 24-08402.	1
25	20-06677	XXM HEADLIGHT MOUNT RIGHT SIDE	1
26	PA-61	BRAKE SWITCH SCREW	1