

Zero Motocycles
S 2015 Exploded Views

ZEV0011 - Lighting

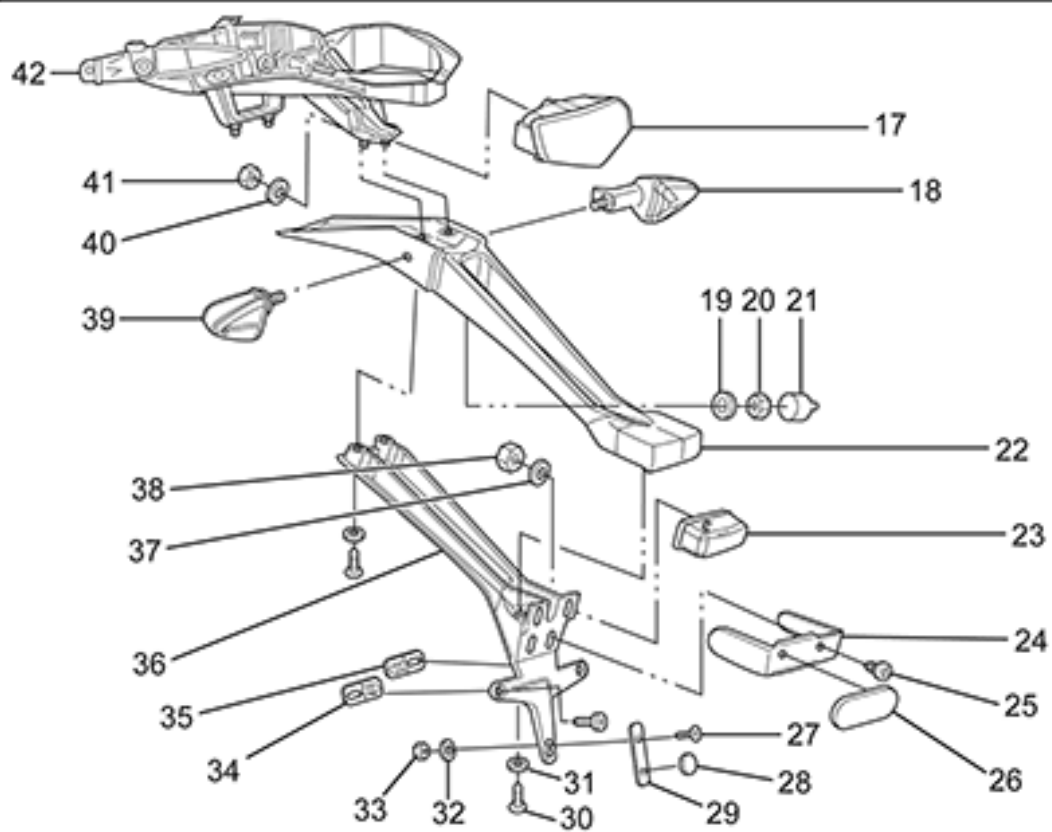
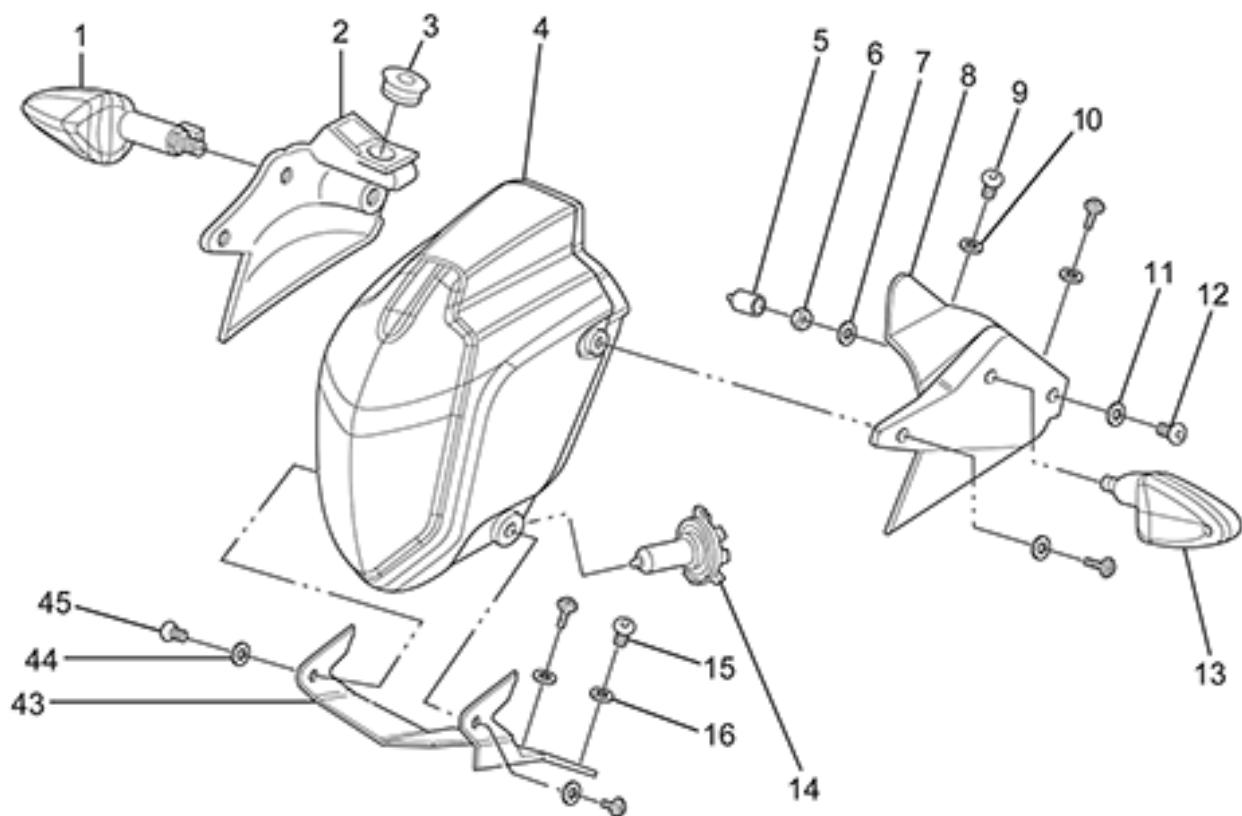

ZEV0011 - Lighting

Callout	Part Number	Part Name	Qty. per Motorcycle
1	65-03462	TURN SIGNAL FR-RH RR-LH	1
2	20-05999	HEADLIGHT MOUNT RIGHT	1
3	20-06938	SDS ACCESSORY OUTLET COVER	1
4	45-03679	HEADLIGHT ASSY, 60/55W, TRIOM	1
5	20-03146	TURN SIGNAL HEX NUT CAP	2
6	90-02072	HEXAGON THIN NUT ISO 4035 M10-04 ZM-F-01 REV 02	2
7	90-02043	TOOTHED LOCK WASHER WITH EXTERNAL TEETH DIN 6797 A M10-B85 ZM-F-01 REV 02	2
8	20-06000	HEADLIGHT MOUNT LEFT	1
9	90-04084	HEXAGON SOCKET BUTTON HEAD CAP SCREW ISO 7380 M5X16-8.8 ZM-F-11 REV 03	4
10	90-04085	WASHER M5 X 11 X 1 NYLON 6/6 BLACK	4
11	90-04085	WASHER M5 X 11 X 1 NYLON 6/6 BLACK	4
12	90-04084	HEXAGON SOCKET BUTTON HEAD CAP SCREW ISO 7380 M5X16-8.8 ZM-F-11 REV 03	4
13	65-03463	TURN SIGNAL FR-LH RR-RH	1
14	65-08002	SDS HEADLIGHT BULB	1
15	90-07281	HEXAGON SOCKET BUTTON HEAD SCREWS ISO 7380 M6X12-8.8 ZM-F-01 REV 03 ZM-L-01 REV 01	2
16	90-02101	HEADLIGHT MOUNTING WASHER	4
17	65-04459	LED TAIL LIGHT TRIOM	1
18	65-03463	TURN SIGNAL FR-LH RR-RH	1
19	90-02043	TOOTHED LOCK WASHER WITH EXTERNAL TEETH DIN 6797 A M10-B85 ZM-F-01 REV 02	2
20	90-02072	HEXAGON THIN NUT ISO 4035 M10-04 ZM-F-01 REV 02	2
21	20-03146	TURN SIGNAL HEX NUT CAP	2
22	24-04439	SDS TAIL POD TOP NOTE: Top half only. Order bottom half PN: 24-05158	1
23	65-04460	LICENSE PLATE LIGHT	1
24	24-05159	REFLECTOR MOUNT BRACKET	1
25	90-05885	PHILIPS HEAD SHEET METAL SCREW 6 X 1/2	10
26	20-03487	REFLECTOR, OVAL, ADH BACK, RED ECIE	1
27	90-05244	HEXAGON SOCKET COUNTERSUNK HEAD SCREW ISO 10642 M5X12-10.9 ZM-F-01 REV 03	4
28	20-05241	LICENSE PLATE BUMPER	1
29	24-05292-1	LICENSE PLATE BRACKET EXTENSIONS NOTE: UR ONLY	1
30	90-07281	HEXAGON SOCKET BUTTON HEAD SCREWS ISO 7380 M6X12-8.8 ZM-F-01 REV 03 ZM-L-01 REV 01	2
31	90-02103	WASHER ISO 7089 6-200HV ZM-F-01 REV 02	10

32	90-04085	WASHER M5 X 11 X 1 NYLON 6/6 BLACK	4
33	90-02053	PREVAILING TORQUE TYPE NUT DIN 985 M5-08 ZM-F-01 REV 02	8
34	24-05161	LICENSE PLATE BRACKET EXTENSIONS NOTE: ONLY USED IN EU/AUS REGIONS	2
35	24-05161	LICENSE PLATE BRACKET EXTENSIONS NOTE: ONLY USED IN EU/AUS REGIONS	2
36	24-05158	SDS TAIL POD BOTTOM NOTE: Bottom half only. Order top half PN: 24-04439	1
37	90-07389	BMS MOUNTING SCREW NEXT TO DIA CONNECTOR	4
38	90-02053	PREVAILING TORQUE TYPE NUT DIN 985 M5-08 ZM-F-01 REV 02	8
39	65-03462	TURN SIGNAL FR-RH RR-LH	1
40	90-02103	WASHER ISO 7089 6-200HV ZM-F-01 REV 02	10
41	90-02054	PREVAILING TORQUE TYPE NUT DIN 985 M6-8 ZM-F-01 REV 02	4
42	20-04876	SDS TAIL FRAME	1
43	20-05910	HEADLIGHT BRACKET	1
44	90-02101	HEADLIGHT MOUNTING WASHER	4
45	90-02545-1	BOLT M6 X 8	1

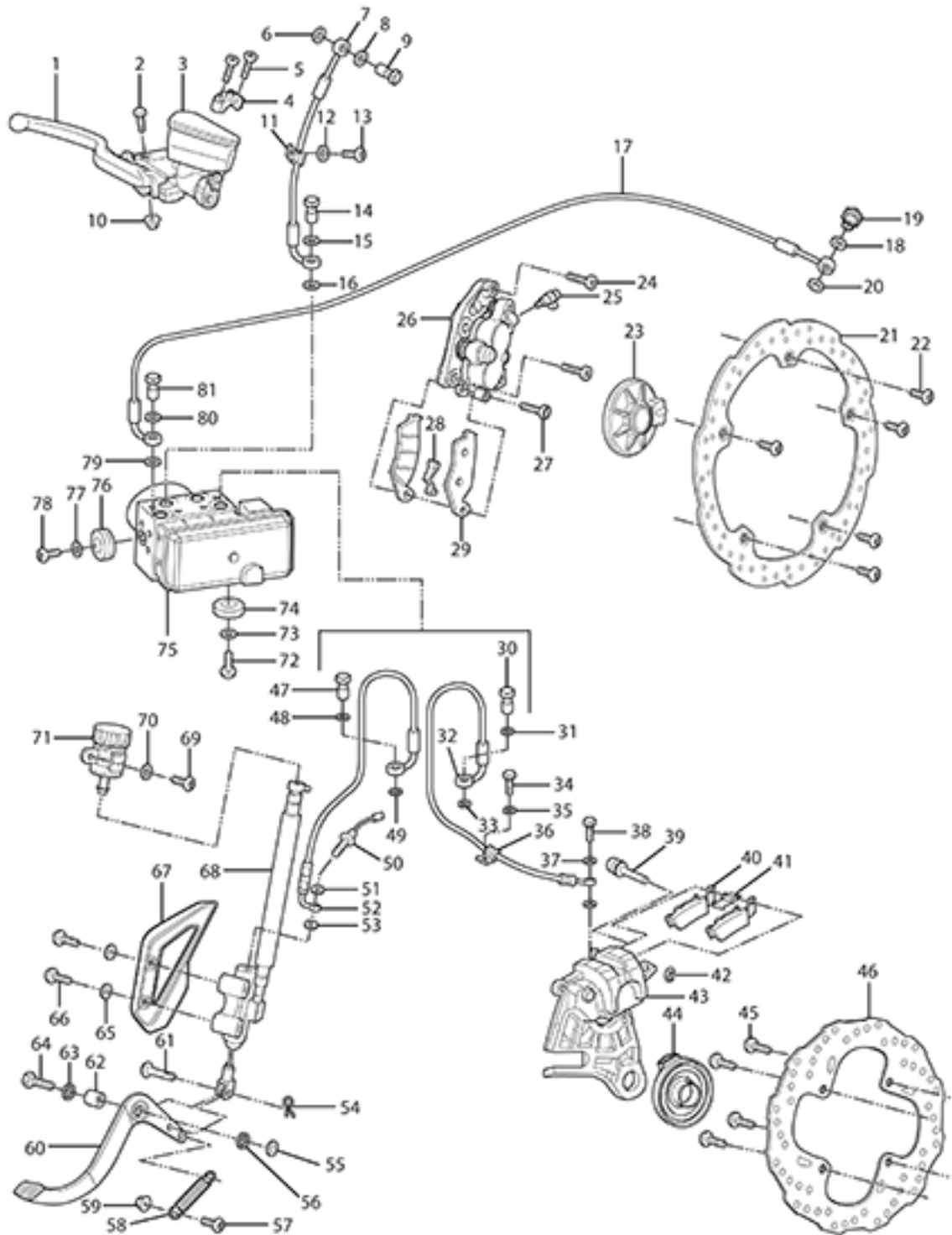

ZEV0012 - Braking

Callout	Part Number	Part Name	Qty. per Motorcycle
1	25-08032	SDS BRAKE JJUAN LEVER	1
2	PA-177	BRAKE LEVER PIVOT BOLT	1
3	25-07682	JJUAN 12.7MM FRONT MASTER CYLINDER SDS/FXS	1
4	25-08064	FRONT MASTER CYLINDER CLAMP KIT NOTE: SDS/XMX NOTE: Mount and Bolts NOTE: Upper Mirror Mount RH	1
5	PA-178	MIRROR POST BOLT 6M X 20	1
6	PA-128	BANJO GASKET	1
7	25-07824	SDS FRONT BRAKE LINE MC TO HCU	1
8	PA-128	BANJO GASKET	1
9	90-08014-3	BANJO BOLT	1
10	PA-130	BRAKE LEVER PIVOT BOLT NUT	1
11	PA-179	BRAKE LINE CLIP	1
12	20-01758-1	BRAKE LINE GUIDE	1
13	90-02545-3	P CLAMP TO TRIPLE CLAMP BOLT	1
14	PA-180	BANJO BOLT	1
15	PA-128	BANJO GASKET	1
16	PA-128	BANJO GASKET	1
17	25-07825	S FRONT BRAKE LINE HCU TO CALIPER	1
18	PA-128	BANJO GASKET	1
19	PA-181	BANJO BOLT	1
20	PA-128	BANJO GASKET	1
21	25-07702	BRAKE ROTOR 320MM FIXED	1
22	90-07833	CUSTOM ROTOR BOLT M8X23MM SHOULDER SCREW	1
23	45-07496	MPI WHEEL SPEED SENSOR	1
24	90-08029	HEXAGON HEAD SCREW ISO 4762 M10-1.25X40-10.9 ZM-F-01 REV03 ZM-L-01 REV01	1
25	PA-182	BLEEDER VALVE	1
26	25-07686	JJUAN 32/30MM FRONT CALIPER SDS	1
27	90-08029	HEXAGON HEAD SCREW ISO 4762 M10-1.25X40-10.9 ZM-F-01 REV03 ZM-L-01 REV01	1
28	PA-183	ANTI RATTLE CLIP	1
29	25-08029	BRAKE PADS SET FRONT SDS	1
30	PA-185	BANJO BOLT	1
31	PA-128	BANJO GASKET	1
32	25-08093	SDS REAR BRAKE LINE HCU TO CALIPER NOTE: Supersedes part number 25-07821.	1
33	PA-128	BANJO GASKET	1
34	90-07292	HEXAGON SOCKET BUTTON HEAD CAP SCREW ISO 7380 M5X16-8.8 ZM-F-11 REV 01 ZM-L-01 REV 01 NOTE: Does not apply to DS	1

35	90-02105	WASHER ISO 7093-1 6-200 HV ZM-F-01 REV 02	1
36	20-01758-1	BRAKE LINE GUIDE	1
37	PA-128	BANJO GASKET	1
38	PA-186	BANJO BOLT AT REAR CALIPER	1
39	PA-187	CALIPER SLIDE BOLT	1
40	25-08030	BRAKE PAD SET SDS REAR	1
41	PA-189	ANTI RATTLE CLIP	1
42	PA-190	CALIPER SLIDE BOLT CLIP	1
43	25-08083	JJUAN 34MM REAR CALIPER SDS NOTE: replacing old p/n: 25-08008	1
44	45-07496	MPI WHEEL SPEED SENSOR	1
45	90-02414	HEXAGON SOCKET BUTTON HEAD SCREW ISO 7380 M8X12-8.8 ZM-F-01 REV 03	1
46	25-07621	BRAKE ROTOR 240MM FIXED WITH COUNTERBORE	1
47	PA-191	BANJO BOLT AT HCU	1
48	PA-128	BANJO GASKET	1
49	PA-128	BANJO GASKET	1
50	PA-192	BRAKE LIGHT SWITCH NOTE: Not sold separately. Please order the Master Cylinder.	1
51	PA-128	BANJO GASKET	1
52	25-07820	SDS REAR BRAKE LINE MC TO HCU	1
53	PA-128	BANJO GASKET	1
54	90-02133	1/4 X 3/4 CLEVIS PIN STEEL ZINC	1
55	90-02100-2	M10 WASHER	1
56	20-02465	IGLIDE BEARING GFM-1416-06	1
57	90-02124-1	BUTTON CAP SCREW M6 X 25	1
58	20-03110	SPRING X BRAKE PEDAL	1
59	20-02465	IGLIDE BEARING GFM-1416-06	1
60	25-02449	X BRAKE PEDAL	1
61	90-02133	1/4 X 3/4 CLEVIS PIN STEEL ZINC	1
62	20-02455	X BRAKE PEDAL SPACER	1
63	20-02465	IGLIDE BEARING GFM-1416-06	1
64	PA-193	BRAKE PEDAL PIVOT BOLT	1
65	PA-194	BRAKE PEDAL PIVOT BOLT WASHER	1
66	PA-195	MASTER CYLINDER BOLT	1
67	25-07457	MASTER CYLINDER GUARD FOR J-JUAN MASTER CYLINDER	1
68	25-08015	JJUAN 12MM REAR MASTER CYLINDER SDS	1
69	90-07273	HEXAGON SOCKET BUTTON HEAD CAP SCREW ISO 7380 M6X16-8.8 ZM-F-01 REV 03 ZM-L-01 REV 01	1
70	PA-196	WASHER	1
71	PA-197	REAR MASTER CYLINDER RESERVOIR	1
72	90-07273	HEXAGON SOCKET BUTTON HEAD CAP SCREW ISO 7380 M6X16-8.8 ZM-F-01 REV 03 ZM-L-01 REV 01	1
73	90-02105	WASHER ISO 7093-1 6-200 HV ZM-F-01 REV 02	1

74	90-08027	GROMMET VIBRATION ISOLATION M6	1
75	25-08092	BOSCH ABS HCU FLUID FILLED 6 PROFILE VARIANTS NOTE: Supersedes part number 25-08081 and 25-08082.	1
76	90-08027	GROMMET VIBRATION ISOLATION M6	1
77	90-02105	WASHER ISO 7093-1 6-200 HV ZM-F-01 REV 02	1
78	90-07273	HEXAGON SOCKET BUTTON HEAD CAP SCREW ISO 7380 M6X16-8.8 ZM-F-01 REV 03 ZM-L-01 REV 01	1
79	PA-128	BANJO GASKET	1
80	PA-128	BANJO GASKET	1
81	PA-185	BANJO BOLT	1

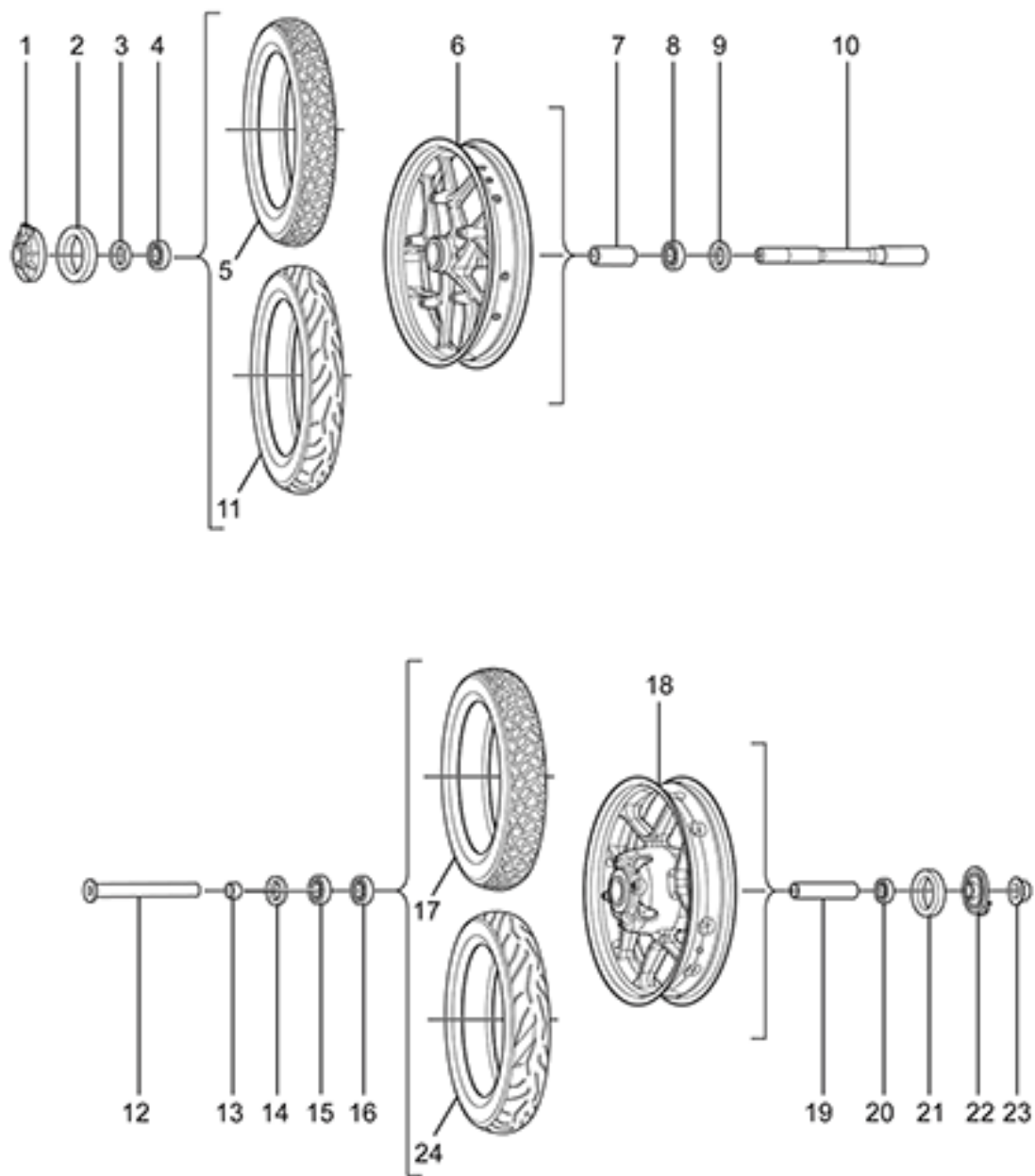

ZEV0013 - Wheel Assy

Callout	Part Number	Part Name	Qty. per Motorcycle
1	45-07496	MPI WHEEL SPEED SENSOR	1
2	25-08080	ABS MAGNET RING	1
3	23-07774	6204 BEARING DUST SEAL	2
4	20-06138	BEARING 6204 NOTE: Bearing used as swing arm bearing in some models and as the wheel bearing (qty of 5; 2 in front and three in rear wheel) in 2015 and later models. NOTE: Manufacturer part number is 6204-2RS	2
5	<i>Not Applicable to this Bike Model</i>		
6	23-08065-4	3.00X17 FRONT CAST WHEEL ASSY SILVER BLACK NOTE: Superseded part number 23-07767-4.	1
7	23-07775	FRONT WHEEL BEARING TUBE	1
8	20-06138	BEARING 6204 NOTE: Bearing used as swing arm bearing in some models and as the wheel bearing (qty of 5; 2 in front and three in rear wheel) in 2015 and later models. NOTE: Manufacturer part number is 6204-2RS	2
9	23-07774	6204 BEARING DUST SEAL	2
10	23-07491	HOLLOW AXLE FRONT	1
11	23-07668	PIRELLI DIABLO ROSSO II, 110/70R17 M/C 54H	1
12	23-08032	REAR AXLE 20MM HOLLOW, ROUNDED END	1
13	23-07489	WHEEL SPACER DRIVE SIDE REAR	1
14	23-07774	6204 BEARING DUST SEAL	2
15	20-06138	BEARING 6204 NOTE: Bearing used as swing arm bearing in some models and as the wheel bearing (qty of 5; 2 in front and three in rear wheel) in 2015 and later models. NOTE: Manufacturer part number is 6204-2RS	2
16	20-06138	BEARING 6204 NOTE: Bearing used as swing arm bearing in some models and as the wheel bearing (qty of 5; 2 in front and three in rear wheel) in 2015 and later models. NOTE: Manufacturer part number is 6204-2RS	2
17	<i>Not Applicable to this Bike Model</i>		
18	23-08056-4	WHEEL 3.50X17 SDS REAR CAST WHEEL ASSY 16MY IMPL BLACK-SILVER C	1
19	23-07776	REAR WHEEL BEARING TUBE 15MY	1
20	20-06138	BEARING 6204 NOTE: Bearing used as swing arm bearing in some models and as the wheel bearing (qty of 5; 2 in front and three in rear wheel) in 2015 and later models. NOTE: Manufacturer part number is 6204-2RS	2

21	25-08080	ABS MAGNET RING	1
22	45-07496	MPI WHEEL SPEED SENSOR	1
23	90-05678	U-NUT M20X1.5 FN 27S 15H (REAR AXLE NUT) NOTE: Rear Axle Nut	1
24	23-07669	PIRELLI DIABLO ROSSO II, 140/70R17 M/C 66H	1

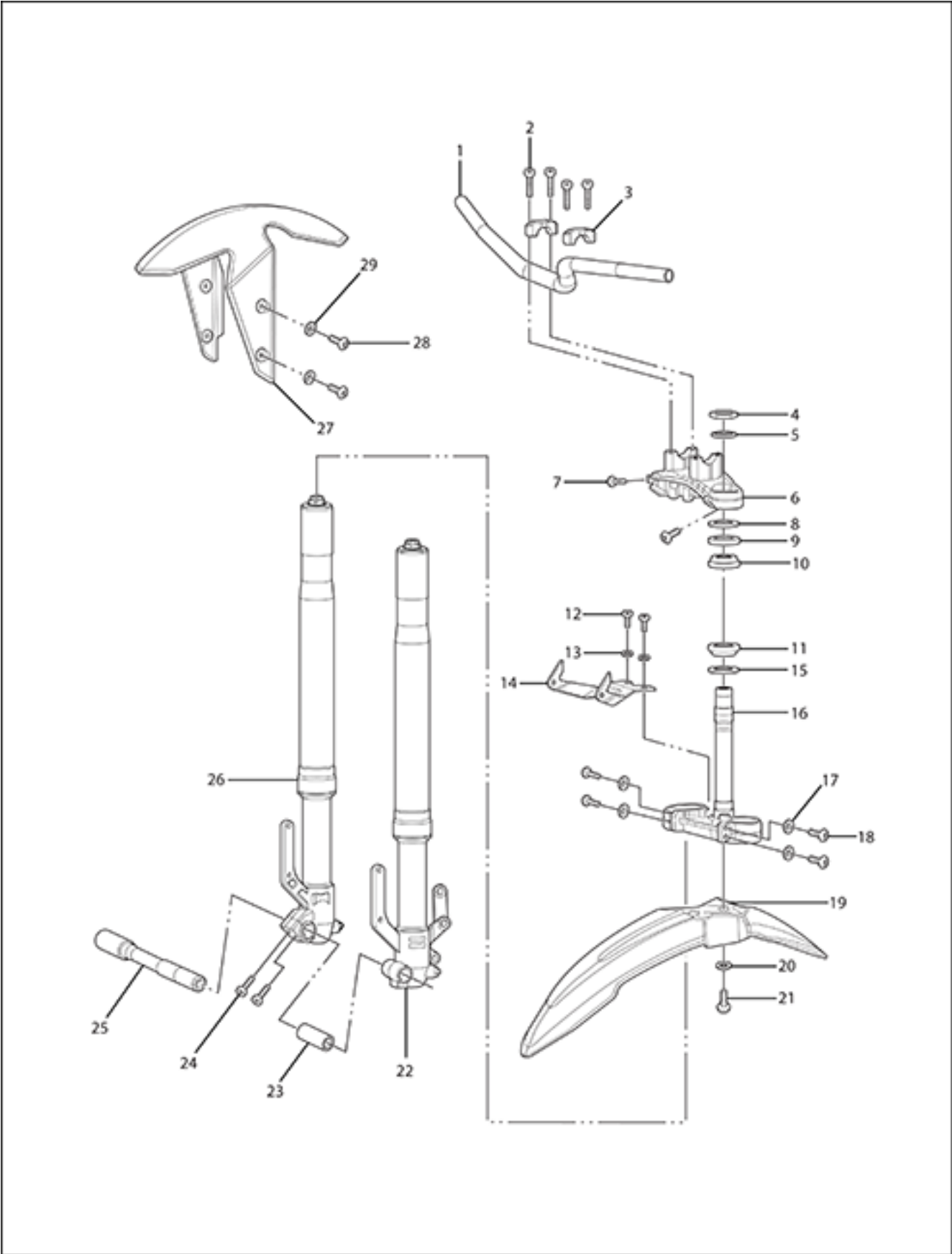

ZEV0014 - Steering Systems

Callout	Part Number	Part Name	Qty. per Motorcycle
1	27-08049	SPORT HANDLEBAR NOTE: Supersedes part number 27-08017.	1
2	90-02096	MOTOR MOUNTING LEFT FRONT TOP AND LEFT FRONT BOTTOM BOLT	1
3	22-00687	S HANDLEBAR CLAMP	1
4	22-06279	STEERING STEM THIN NUT M27 X 1.5 X 8MM	1
5	20-06278	WASHER 41 - 27.5 X 2 MM	1
6	22-07622	SDS UPPER TRIPLE CLAMP 15MY IMP	1
7	90-02094	HEXAGON SOCKET HEAD CAP SCREW ISO 4762 M8X25-10.9 ZM-F-01 REV 03	1
8	22-06257	STEERING STEM LOCK NUT M 30 X1.5 MM	1
9	81-08045	BEARING LIP SEAL OVERMOLDED 55MM OD NOTE: Supersedes part 20-06113	1
10	20-06068	STEERING HEAD BEARING KOYO SAC3055-1	1
11	20-06068	STEERING HEAD BEARING KOYO SAC3055-1	1
12	90-02109	HEXAGON SOCKET BUTTON HEAD CAP SCREW ISO 7380 M5X12-8.8 ZM-F-01 REV 03	1
13	90-02101	HEADLIGHT MOUNTING WASHER	1
14	20-05910	HEADLIGHT BRACKET	1
15	81-08045	BEARING LIP SEAL OVERMOLDED 55MM OD NOTE: Supersedes part 20-06113	1
16	22-07624	SDS LOWER TRIPLE CLAMP ASSY 15MY IMP NOTE: Superseded by 22-08082	1
17	90-02104	WASHER ISO 7089 -8-200 HV ZM-F-01 REV 02	1
18	90-02094	HEXAGON SOCKET HEAD CAP SCREW ISO 4762 M8X25-10.9 ZM-F-01 REV 03	1
19	<i>Not Applicable to this Bike Model</i>		
20	<i>Not Applicable to this Bike Model</i>		
21	<i>Not Applicable to this Bike Model</i>		
22	22-05874	S FORK 41MM LEFT	1
23	PA-204	INNER BEARING SPACER	1
24	PA-205	M8 X 30 BOLT	1
25	23-07491	HOLLOW AXLE FRONT	1
26	22-05875	S FORK 41MM RIGHT	1
27	24-08027-7	FRONT FENDER STREET TO WORK WITH SHOWA SUSPENSION YELLOW #2	1
28	90-07292	HEXAGON SOCKET BUTTON HEAD CAP SCREW ISO 7380 M5X16-8.8 ZM-F-11 REV 01 ZM-L-01 REV 01 NOTE: Does not apply to DS	1
29	90-04085	WASHER M5 X 11 X 1 NYLON 6/6 BLACK	1

ZEV0015 - Body Trim

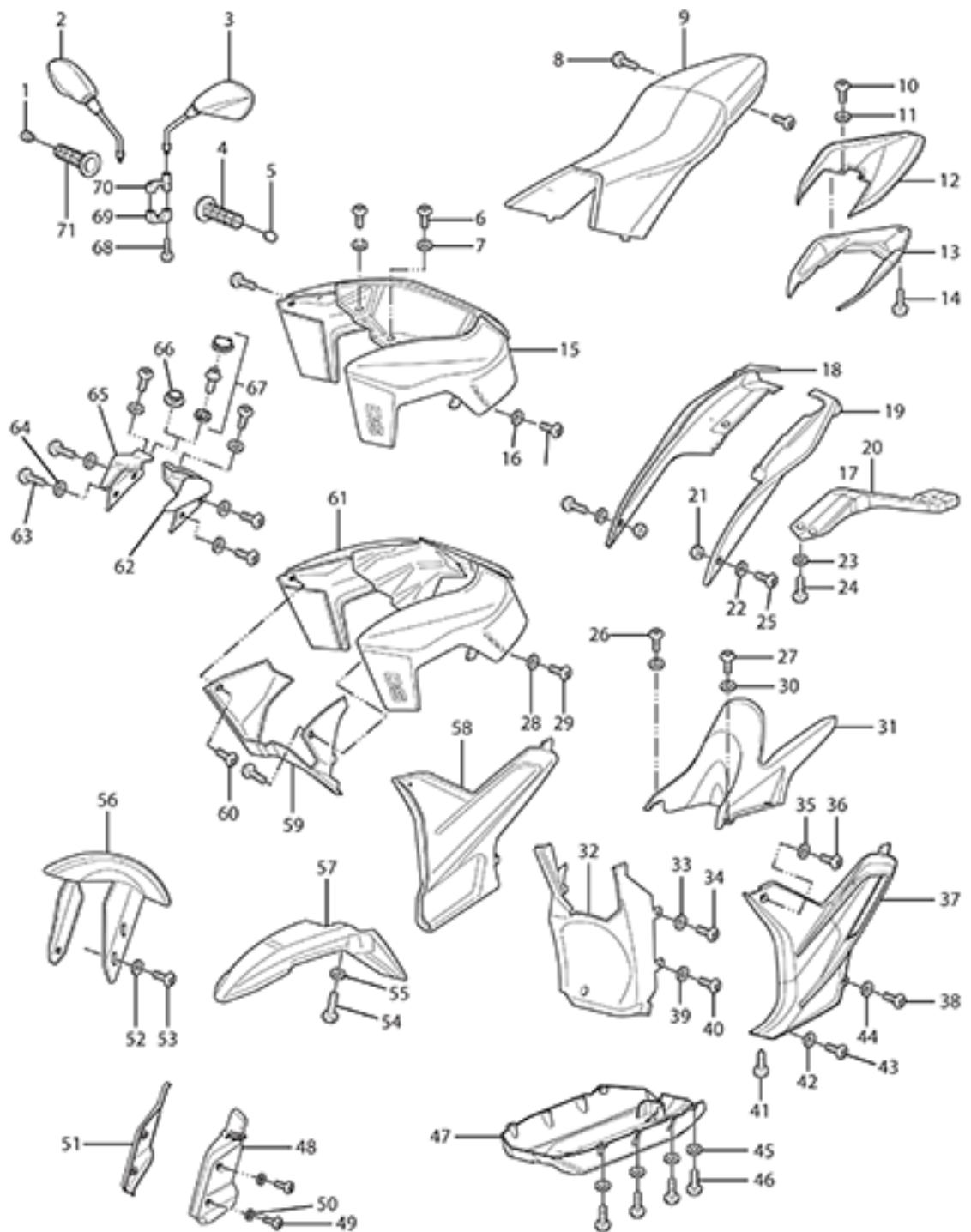

ZEV0015 - Body Trim

Callout	Part Number	Part Name	Qty. per Motorcycle
1	27-08002	RIDER INTERFACE MISCELLANEOUS COMPONENT HANDLEBAR END CAP	1
2	27-08057	MIRROR RH NOTE: Supersedes part number 27-08004.	1
3	27-08056	MIRROR LH NOTE: Supersedes part number 27-08003.	1
4	27-08007	HAND GRIP LEFT SIDE	1
5	27-08002	RIDER INTERFACE MISCELLANEOUS COMPONENT HANDLEBAR END CAP	1
6	90-04084	HEXAGON SOCKET BUTTON HEAD CAP SCREW ISO 7380 M5X16-8.8 ZM-F-11 REV 03	1
7	90-04085	WASHER M5 X 11 X 1 NYLON 6/6 BLACK	1
8	90-08005	SEAT BOLT M8X55 NOTE: Supersedes 90-07009.	1
9	24-04854	SDS SEAT ASSEMBLY	1
10	PA-41	BOLT	1
11	PA-42	WASHER	1
12	24-04432-1	SDS TAIL TOP BLACK#2	1
12	24-04432-7	SDS TAIL TOP YELLOW #2	1
13	24-04433-7	SDS TAIL BOTTOM YELLOW #2	1
13	24-08099	SDS TAIL BOTTOM BLACK/BASE NOTE: 24-08099 Black (unpainted) tail top bottom. Used as the base for the 17MY painted colors.	1
14	90-05885	PHILIPS HEAD SHEET METAL SCREW 6 X 1/2	1
15	24-08205-1	S TANK ASSEMBLY BLACK NOTE: Does not apply to SR or Power Tank option NOTE: Does not include tank bag NOTE: replacing old p/n:24-05327-1	1
15	24-08205-7	S TANK ASSEMBLY YELLOW NOTE: Supersedes part number 24-05327-7. Note that the 13MY yellow was different from 14MY and later.	1
16	90-04085	WASHER M5 X 11 X 1 NYLON 6/6 BLACK	1
17	90-04084	HEXAGON SOCKET BUTTON HEAD CAP SCREW ISO 7380 M5X16-8.8 ZM-F-11 REV 03	1
18	24-04434	TRUNK PAN RIGHT	1
19	24-04435	TRUNK PAN LEFT	1
20	24-04439	SDS TAIL POD TOP NOTE: Top half only. Order bottom half PN: 24-05158	1
21	PA-43	NUT	1
22	PA-44	WASHER	1

23	90-02103	WASHER ISO 7089 6-200HV ZM-F-01 REV 02	1
24	90-07281	HEXAGON SOCKET BUTTON HEAD SCREWS ISO 7380 M6X12-8.8 ZM-F-01 REV 03 ZM-L-01 REV 01	1
25	PA-45	BOLT	1
26	PA-46	BOLT	1
27	PA-47	BOLT	1
28	90-04085	WASHER M5 X 11 X 1 NYLON 6/6 BLACK	1
29	90-04084	HEXAGON SOCKET BUTTON HEAD CAP SCREW ISO 7380 M5X16-8.8 ZM-F-11 REV 03	1
30	PA-48	WASHER	1
31	24-08157	REAR INNER FENDER NOTE: Supersedes part number 24-04438	1
32	24-07674	SDS STUBBY CHIN CENTER	1
33	90-04085	WASHER M5 X 11 X 1 NYLON 6/6 BLACK	1
34	90-04084	HEXAGON SOCKET BUTTON HEAD CAP SCREW ISO 7380 M5X16-8.8 ZM-F-11 REV 03	1
35	90-04085	WASHER M5 X 11 X 1 NYLON 6/6 BLACK	1
36	90-04084	HEXAGON SOCKET BUTTON HEAD CAP SCREW ISO 7380 M5X16-8.8 ZM-F-11 REV 03	1
37	24-06684	SDS CHIN FAIRING LEFT NOTE: Please order 80-06733 GRAPHIC LABEL SANTA CRUZ separately.	1
38	90-04084	HEXAGON SOCKET BUTTON HEAD CAP SCREW ISO 7380 M5X16-8.8 ZM-F-11 REV 03	1
39	90-04085	WASHER M5 X 11 X 1 NYLON 6/6 BLACK	1
40	90-04084	HEXAGON SOCKET BUTTON HEAD CAP SCREW ISO 7380 M5X16-8.8 ZM-F-11 REV 03	1
41	90-04084	HEXAGON SOCKET BUTTON HEAD CAP SCREW ISO 7380 M5X16-8.8 ZM-F-11 REV 03	1
42	90-04085	WASHER M5 X 11 X 1 NYLON 6/6 BLACK	1
43	90-04084	HEXAGON SOCKET BUTTON HEAD CAP SCREW ISO 7380 M5X16-8.8 ZM-F-11 REV 03	1
44	90-04085	WASHER M5 X 11 X 1 NYLON 6/6 BLACK	1
45	PA-206	BATTERY RETAINING RAIL	1
46	90-02109	HEXAGON SOCKET BUTTON HEAD CAP SCREW ISO 7380 M5X12-8.8 ZM-F-01 REV 03	1
47	24-07746	STRUCTURAL PLASTIC SKID PAN	1
48	<i>Not Applicable to this Bike Model</i>		
49	<i>Not Applicable to this Bike Model</i>		
50	<i>Not Applicable to this Bike Model</i>		
51	<i>Not Applicable to this Bike Model</i>		
52	90-07292	HEXAGON SOCKET BUTTON HEAD CAP SCREW ISO 7380 M5X16-8.8 ZM-F-11 REV 01 ZM-L-01 REV 01 NOTE: Does not apply to DS	1
53	90-04085	WASHER M5 X 11 X 1 NYLON 6/6 BLACK	1

54	<i>Not Applicable to this Bike Model</i>		
55	<i>Not Applicable to this Bike Model</i>		
56	24-08027-1	FRONT FENDER STREET TO WORK WITH SHOWA SUSPENSION BLACK #2	1
56	24-08027-7	FRONT FENDER STREET TO WORK WITH SHOWA SUSPENSION YELLOW #2	1
57	<i>Not Applicable to this Bike Model</i>		
58	24-08235	SDS CHIN FAIRING RIGHT NOTE: Please order 80-06733 GRAPHIC LABEL SANTA CRUZ or 80-08012 CRAFTED IN CALIFORNIA JEWEL. NOTE: Supersedes part number 24-06685.	1
59	24-04428	SDS FAIRING FRONT CENTER BLACK#2	1
60	90-05885	PHILIPS HEAD SHEET METAL SCREW 6 X 1/2	1
61	24-08207-1	S POWER TANK ASSEMBLY BLACK	1
61	24-08207-7	S POWER TANK ASSEMBLY YELLOW	1
62	20-06000	HEADLIGHT MOUNT LEFT	1
63	90-04084	HEXAGON SOCKET BUTTON HEAD CAP SCREW ISO 7380 M5X16-8.8 ZM-F-11 REV 03	1
64	90-04085	WASHER M5 X 11 X 1 NYLON 6/6 BLACK	1
65	20-05999	HEADLIGHT MOUNT RIGHT	1
66	20-06938	SDS ACCESSORY OUTLET COVER	1
67	10-07504	12V ACCESSORY SOCKET KIT - SDS NOTE: Charge a GPS, smart phone or mp3 player using the Zero Motorcycles 12V Accessory Socket Kit. Designed to connect directly to your motorcycle{###}'s power port harness, the accessory socket enables you to charge small devices that have a cigarette lighter plug. The accessory outlet is rated up to 10 amps/120 watts. This kit includes all mounting hardware for installation on the 2014 and later Zero S, Zero DS and Zero SR motorcycles. NOTE: 2014 [Zero SR, Zero S, Zero DS] 2015 [Zero SR, Zero S, Zero DS] 2016-2017 [Zero SR, Zero S, Zero DS, Zero DSR]	1
68	90-07265	HEXAGON SOCKET HEAD CAP SCREW ISO 4762 M6X20-8.8 ZM-F-01 REV 03 ZM-L-01 REV 01	1
69	24-02961	MIRROR MOUNT CLAMP	1
70	24-02913	MIRROR MOUNT BODY LH THREAD	1
71	27-08006	HAND GRIP THROTTLE SIDE	1

ZEV0016 - Rear Suspension

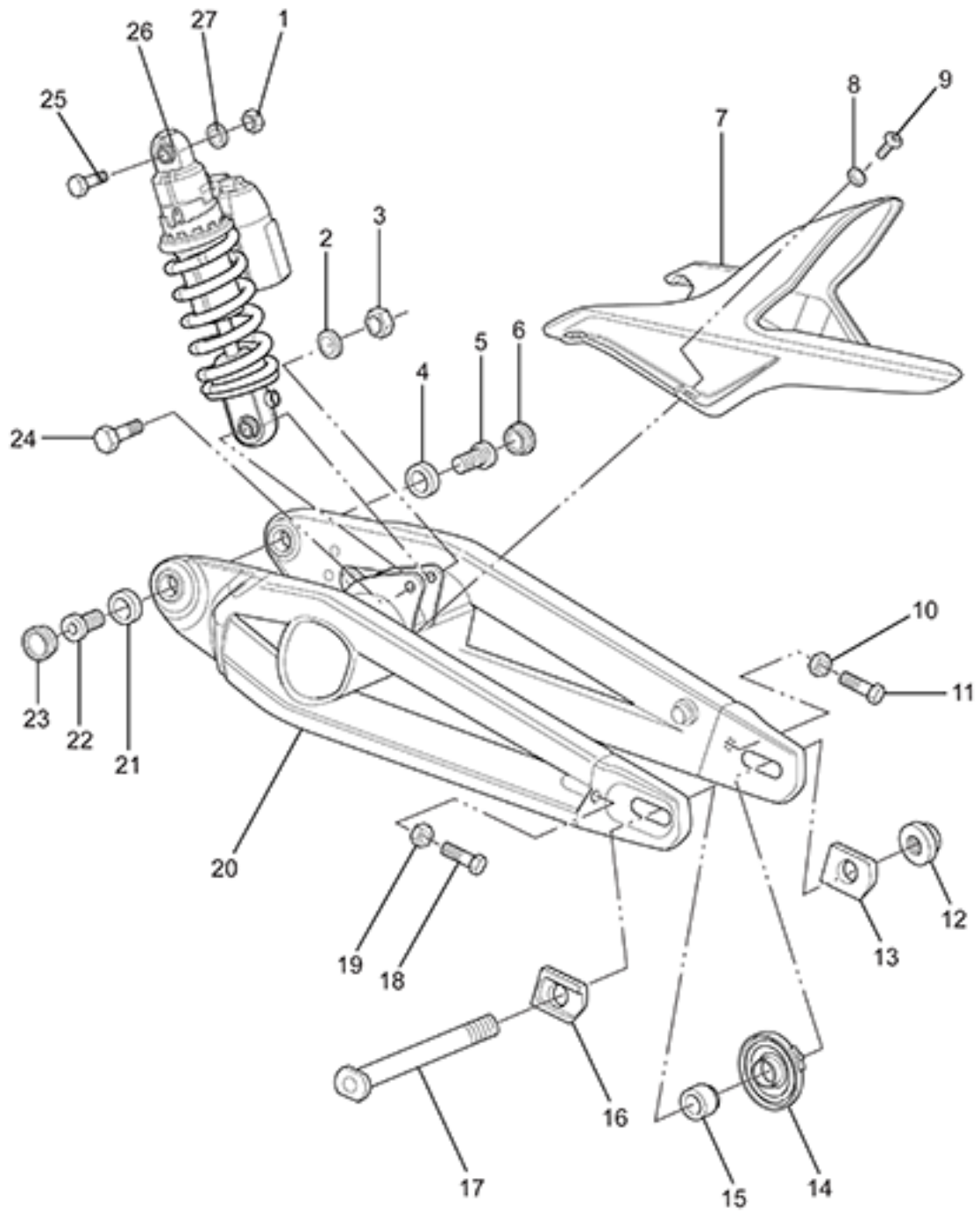

ZEV0016 - Rear Suspension

Callout	Part Number	Part Name	Qty. per Motorcycle
1	90-02050	PREVAILING TORQUE TYPE NUT DIN 985 M10-8 ZM-F-01 REV 02	1
2	90-02100-2	M10 WASHER	1
3	90-02050	PREVAILING TORQUE TYPE NUT DIN 985 M10-8 ZM-F-01 REV 02	1
4	20-06138	BEARING 6204 NOTE: Bearing used as swing arm bearing in some models and as the wheel bearing (qty of 5; 2 in front and three in rear wheel) in 2015 and later models. NOTE: Manufacturer part number is 6204-2RS	1
5	20-06130	STUB AXLE	1
6	20-06937	SDS STUB-PIVOT COVER	1
7	24-04438	REAR INNER FENDER NOTE: Superseded by 24-08157	1
8	90-04085	WASHER M5 X 11 X 1 NYLON 6/6 BLACK	1
9	90-02109	HEXAGON SOCKET BUTTON HEAD CAP SCREW ISO 7380 M5X12-8.8 ZM-F-01 REV 03	1
10	90-05088	HEXAGON FLANGE NUT DIN 6923 M8-1.25 ZM-F-01 REV 03	1
11	90-03030	HEXAGON HEAD SCREW DIN 933 M8X40-10.9 ZM-F-01 REV 03	1
12	90-05678	U-NUT M20X1.5 FN 27S 15H (REAR AXLE NUT) NOTE: Rear Axle Nut	1
13	20-04738	REAR AXLE ADJUSTER PUSH BLOCK, NUT SIDE	1
14	45-07496	MPI WHEEL SPEED SENSOR	1
15	23-07489	WHEEL SPACER DRIVE SIDE REAR	1
16	20-04737	REAR AXLE ADJUSTER PUSH BLOCK, HEAD SIDE	1
17	23-04736	AXLE 20MM HOLLOW NOTE: Superseded by pn:23-08032	1
18	90-03030	HEXAGON HEAD SCREW DIN 933 M8X40-10.9 ZM-F-01 REV 03	1
19	90-05088	HEXAGON FLANGE NUT DIN 6923 M8-1.25 ZM-F-01 REV 03	1
20	21-07747	S SWINGARM	1
21	20-06138	BEARING 6204 NOTE: Bearing used as swing arm bearing in some models and as the wheel bearing (qty of 5; 2 in front and three in rear wheel) in 2015 and later models. NOTE: Manufacturer part number is 6204-2RS	1
22	20-06130	STUB AXLE	1
23	20-06937	SDS STUB-PIVOT COVER	1
24	90-05711	LOWER SHOCK EYE BOLT M10-1.5X60MM	1

25	90-05711	LOWER SHOCK EYE BOLT M10-1.5X60MM	1
26	22-05881	S SHOCK 40MM NOTE: not applicable in DS	1
27	90-02100-2	M10 WASHER	1

ZEV0017 - Frame(Left)

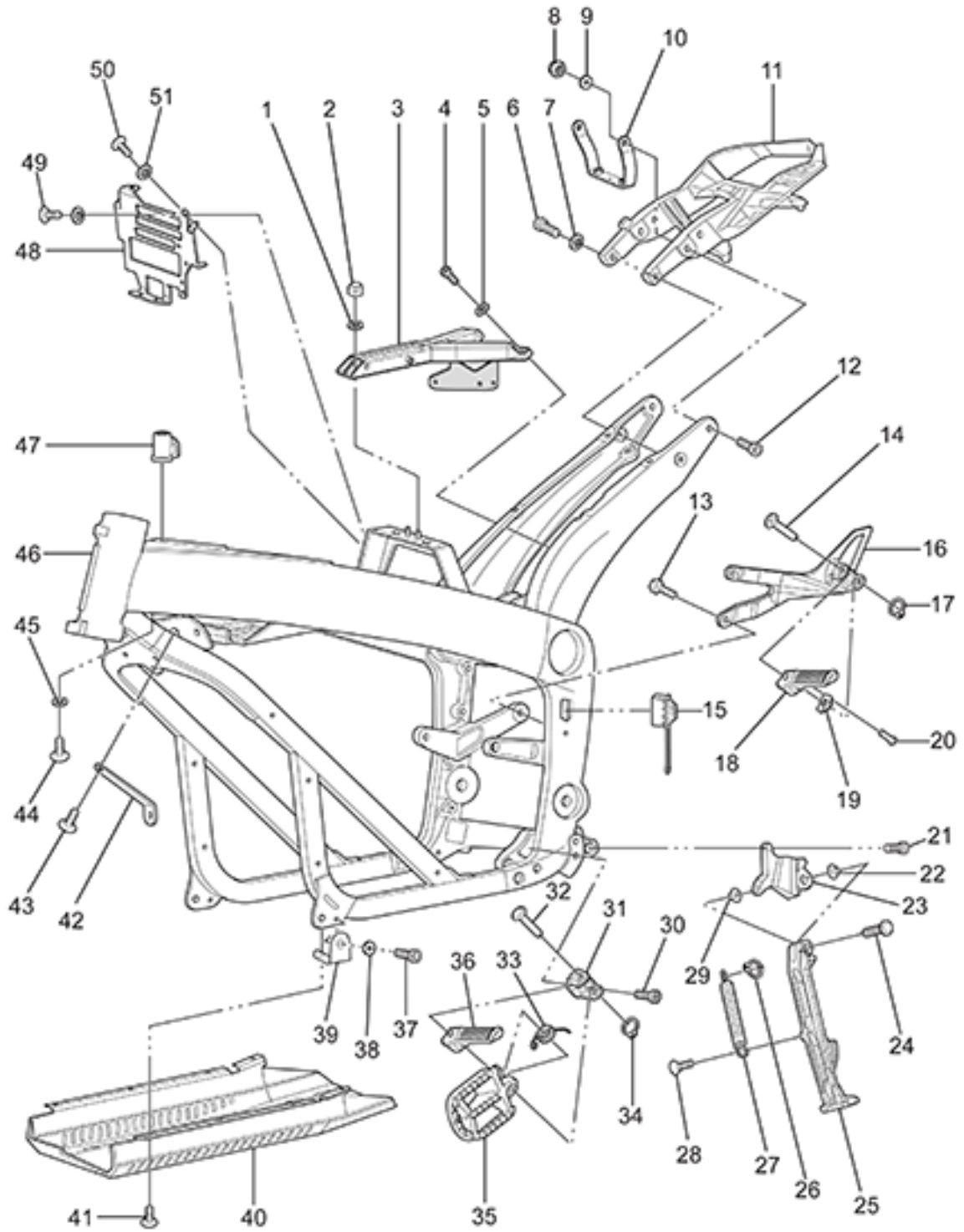

ZEV0017 - Frame(Left)

Callout	Part Number	Part Name	Qty. per Motorcycle
1	90-02103	WASHER ISO 7089 6-200HV ZM-F-01 REV 02	1
2	90-02054	PREVAILING TORQUE TYPE NUT DIN 985 M6-8 ZM-F-01 REV 02	1
3	21-06979	SDS SEAT FRAME WITH FUSEPANEL MOUNT	1
4	90-02122	HEXAGON SOCKET BUTTON HEAD CAP SCREW ISO 7380 M6X16-8.8 ZM-F-01 REV 03	1
5	90-02103	WASHER ISO 7089 6-200HV ZM-F-01 REV 02	1
6	90-04103	TAIL FRAME BOLT HEX HEAD 8MM - 1.00 X 30MM	1
7	90-02104	WASHER ISO 7089 -8-200 HV ZM-F-01 REV 02	1
8	90-03236	PREVAILING TORQUE TYPE NUT DIN 985 M8-10 ZM-F-01 REV 02	1
9	90-02104	WASHER ISO 7089 -8-200 HV ZM-F-01 REV 02	1
10	<i>Not Applicable to this Bike Model</i>		
11	20-04876	SDS TAIL FRAME	1
12	90-04103	TAIL FRAME BOLT HEX HEAD 8MM - 1.00 X 30MM	1
13	PA-50	PASSENGER CLEVIS BRACKET BOLT 8MM - 1.25 X 25MM	1
14	90-02725-06	CLEVIS PIN CUSTOM 10MM X 45L	1
15	45-04864	CAVITY PLUG C13	1
16	20-04285	SDS PASSENGER PEG BRKT L	1
17	90-02879	RETAINING RING 9MM SHAFT	1
18	20-05228	FOOTPEG LT PASSENGER	1
19	20-04279	FOOTPEG DETENT PLATE	1
20	20-05404	FOOTPEG DETENT BALL MECHANISM	1
21	90-07277	HEXAGON SOCKET THIN HEAD CAP SCREW DIN 7984 M10X25-8.8 ZM-F-01 REV 03 ZM-L-01 REV 01	1
22	90-02800	BUSHING FLANGE 0.375	1
23	20-06590	KICKSTAND MOUNT	1
24	90-02799	CLEVIS PIN CUSTOM NOTE: Used to attach kickstand leg to mount.	1
25	20-05660	SHORT KICKSTAND LEG W/MAGNET	1
26	90-02837	E CLIP 0.375	1
27	20-00710	S KS SPRING OUT	1
28	90-07261	HEXAGON SOCKET COUNTERSUNK HEAD SCREW ISO 10642 M8X20-10.9 ZM-F-01 REV 03 ZM-L-01 REV 01	1
29	90-02800	BUSHING FLANGE 0.375	1
30	90-07277	HEXAGON SOCKET THIN HEAD CAP SCREW DIN 7984 M10X25-8.8 ZM-F-01 REV 03 ZM-L-01 REV 01	1
31	20-02723	CLEVIS FOOT PEG UNIVERSAL LEFT	1
32	90-02725-06	CLEVIS PIN CUSTOM 10MM X 45L	1
33	20-02727	TORSION SPRING, .678 OD .078 WIRE, CCW	1

34	90-02879	RETAINING RING 9MM SHAFT	1
35	<i>Not Applicable to this Bike Model</i>		
36	20-04305	FOOTPEG LT RIDER	1
37	90-07288	HEXAGON SOCKET HEAD CAP SCREW ISO 4762 M5X12-8.8 ZM-F-01 REV 03 ZM-L-01 REV 01	1
38	PA-51	M5 FLAT WASHER	1
39	20-05307	SKID PAN BRACKET	1
40	20-05126	SDS SKID PAN NOTE: Superseded by part number 26-08051.	1
41	90-02109	HEXAGON SOCKET BUTTON HEAD CAP SCREW ISO 7380 M5X12-8.8 ZM-F-01 REV 03	1
42	20-07073	SDS FRAME MOUNTED HORN BRACKET	1
43	90-02128	HEXAGON SOCKET BUTTON HEAD CAP SCREW ISO 7380 M8X20-8.8 ZM-F-01 REV 03	1
44	90-07281	HEXAGON SOCKET BUTTON HEAD SCREWS ISO 7380 M6X12-8.8 ZM-F-01 REV 03 ZM-L-01 REV 01	1
45	90-02103	WASHER ISO 7089 6-200HV ZM-F-01 REV 02	1
46	26-08101	FRAME S NOTE: Must supply proof of destruction of old frame along with VIN# and/or Claim# for replacement. NOTE: Supersedes 21-07500	1
47	20-05202	KEYSWITCH LOCK AND TANK BAG LOCK COMBO KIT NOTE: This Kit includes an ignition lock (45-02692) and a tank bag/helmet lock (p/n 20-05044) that have been keyed alike with two keys.	1
48	20-07736	ELECTRICAL PANEL MOUNT PLATE NOTE: Superseded by 26-08120.	1
49	PA-52	ELECTRICAL BRACKET BOLT HEX HEAD M5 - 0.80 X 12MM	1
50	PA-53	ELECTRICAL BRACKET BOLT HEX HEAD M5 - 0.80 X 12MM	1
51	PA-54	ELECTRICAL PANEL BOLT WASHER, M5 FLAT WASHER	1

ZEV0018 - Frame(Right)

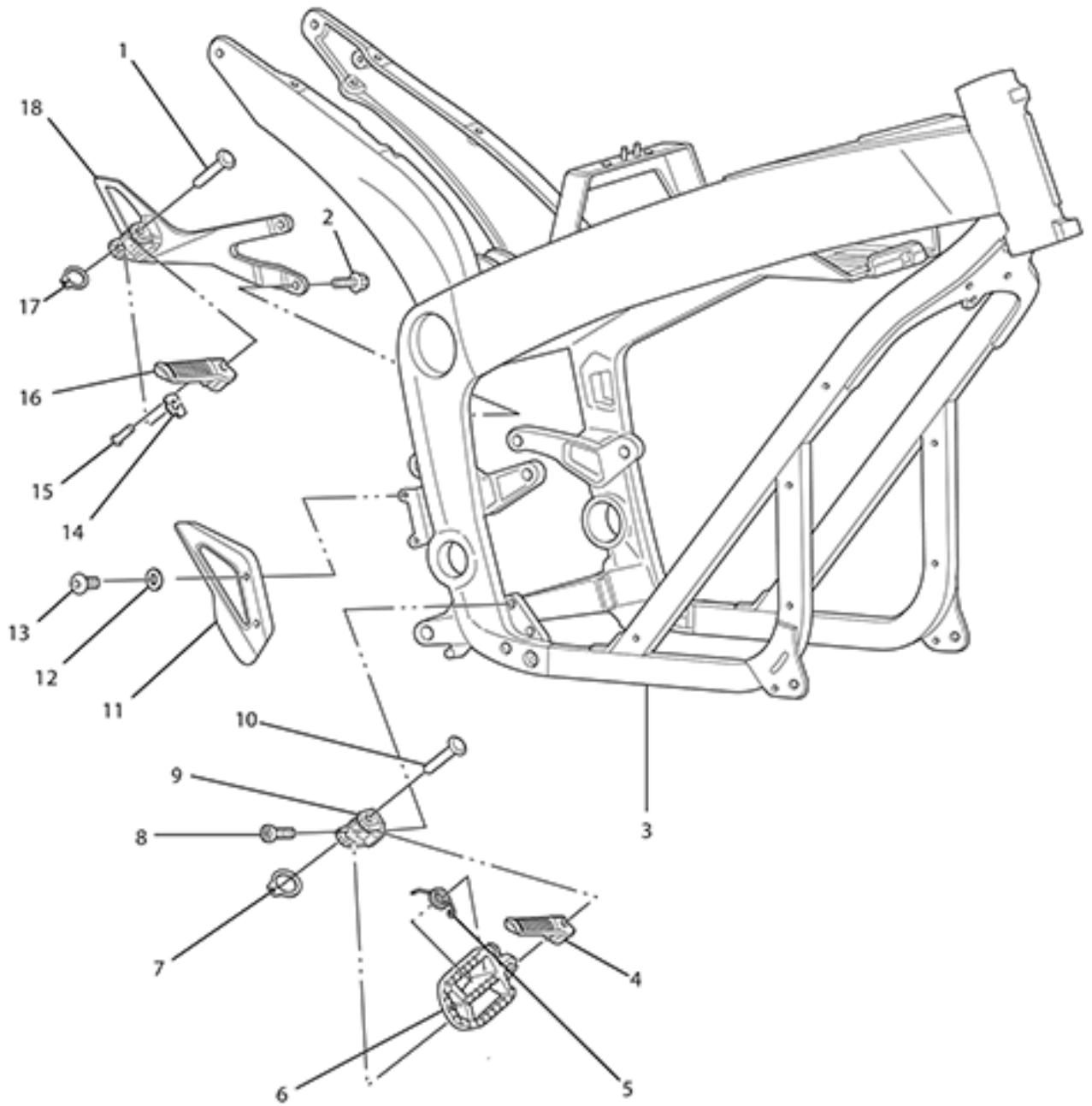

ZEV0018 - Frame(Right)

Callout	Part Number	Part Name	Qty. per Motorcycle
1	90-02725-06	CLEVIS PIN CUSTOM 10MM X 45L	1
2	PA-206	BATTERY RETAINING RAIL	1
3	26-08101	FRAME S NOTE: Must supply proof of destruction of old frame along with VIN# and/or Claim# for replacement. NOTE: Supersedes 21-07500	1
4	20-04304	FOOTPEG RT RIDER NOTE: Does not apply to DS	1
5	20-02727	TORSION SPRING, .678 OD .078 WIRE, CCW	1
6	<i>Not Applicable to this Bike Model</i>		
7	90-02879	RETAINING RING 9MM SHAFT	1
8	90-07277	HEXAGON SOCKET THIN HEAD CAP SCREW DIN 7984 M10X25-8.8 ZM-F-01 REV 03 ZM-L-01 REV 01	1
9	20-02724	CLEVIS FOOT PEG UNIVERSAL RIGHT	1
10	90-02725-06	CLEVIS PIN CUSTOM 10MM X 45L	1
11	25-07457	MASTER CYLINDER GUARD FOR J-JUAN MASTER CYLINDER	1
12	90-02103	WASHER ISO 7089 6-200HV ZM-F-01 REV 02	1
13	90-07323	HEXAGON SOCKET BUTTON HEAD CAP SCREW ISO 7380 M6X25-8.8 ZM-F-01 REV 03 ZM-L-01 REV 01	1
14	20-04279	FOOTPEG DETENT PLATE	1
15	20-05404	FOOTPEG DETENT BALL MECHANISM	1
16	20-05227	FOOTPEG RT PASSENGER	1
17	90-02879	RETAINING RING 9MM SHAFT	1
18	20-04284	SDS PASSENGER PEG BRKT R NOTE: superseded by 20-07604	1

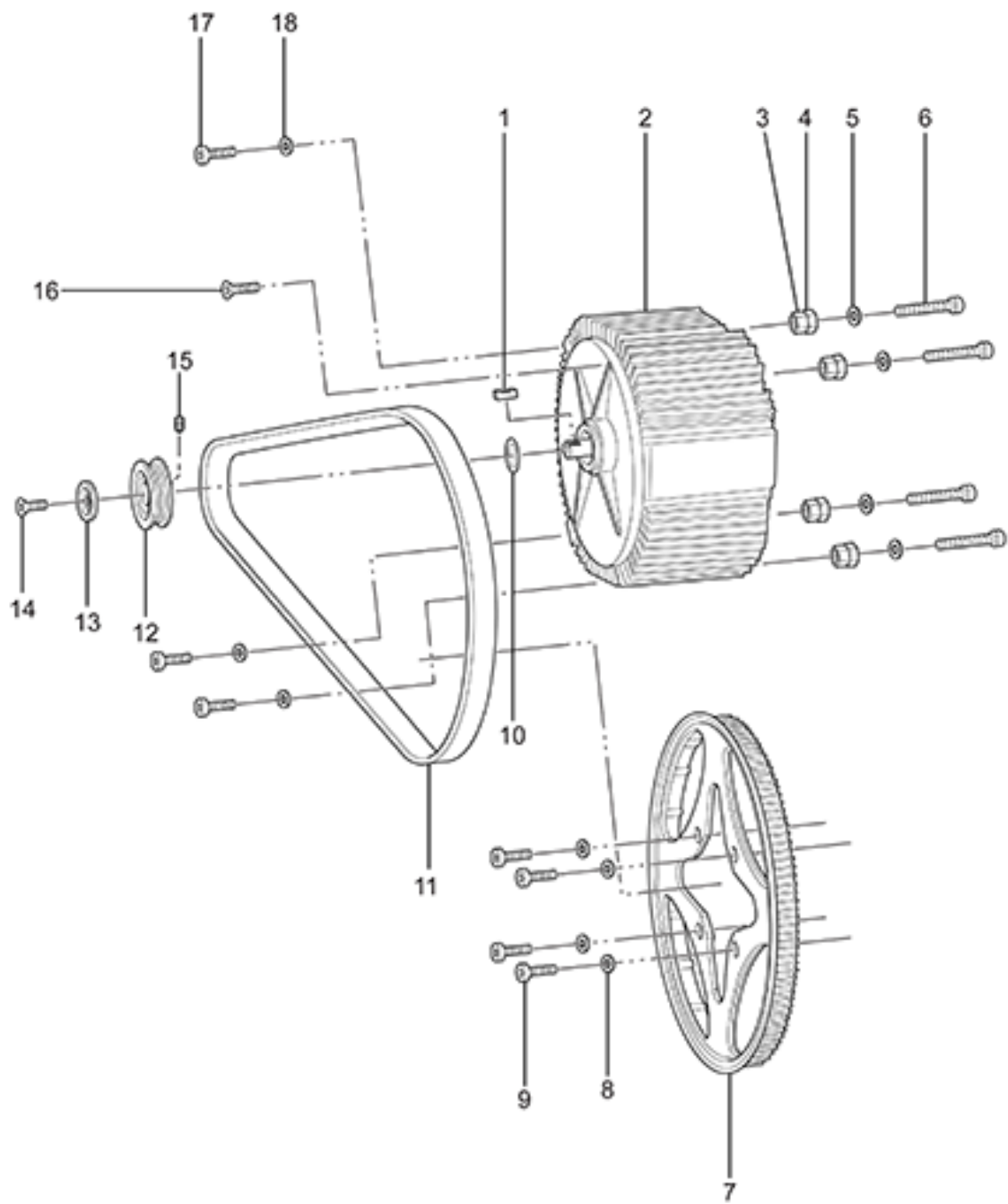

ZEV0019 - Motor and Drive System

Callout	Part Number	Part Name	Qty. per Motorcycle
1	30-06745	SHAFT KEY .25 MOTOR SPROCKET NOTE: Motor Sprocket	1
2	12-08034	ZERO SDS 75-7 MOTOR REPLACEMENT KIT NOTE: Must Provide Warranty Claim and VIN# when ordering NOTE: Old Part# 30-07771	1
3	90-04783	HEXAGON NUT ISO 4033 M14-2 ZM-F-01 REV 03	1
4	20-04774	MOTOR JACK SCREW INNER	1
5	90-02104	WASHER ISO 7089 -8-200 HV ZM-F-01 REV 02	1
6	90-05179	HEXAGON SOCKET HEAD CAP SCREW ISO 4762 M8X60-8.8 ZM-F-01 REV 03	1
7	30-03672	SPROCKET REAR BELT DRIVE 132T, 8MM PITCH, 17MM WIDE CASTING NOTE: Please order 30-04051	1
7	30-04051	SPROCKET REAR BELT DRIVE 132T, 8MM PITCH, 17MM WIDE FINISHED	1
8	90-02104	WASHER ISO 7089 -8-200 HV ZM-F-01 REV 02	1
9	90-07289	HEXAGON SOCKET THIN HEAD CAP SCREW DIN 7984 M8X30-8.8 ZM-F-01 REV 03 ZM-L-01 REV 01 NOTE: THIN HEAD CAP SCREW DIN 7984 M8X30-8.8	1
10	30-05502	MOTOR SHAFT SPACER 1.5 MM FOR 1" SHAFT	1
11	30-08084	BELT DRIVE, 220T, 8MM PITCH, 14MM WIDE, NEW LOGO	1
12	30-03657	SPROCKET FRONT, BELT DRIVE 28T, 8MM PITCH, 15MM WIDE 1" BORE NOTE: Does not apply to SR	1
13	20-05453	LOW PROFILE BELT SPROCKET MOTOR SHAFT TOPHAT	1
14	90-02056	HEXAGON SOCKET COUNTERSUNK HEAD SCREW M10X25-8.8 MOTOR SHAFT NOTE: Bolt used to hold front sprocket in place onto the motor shaft. NOTE: Sprocket	1
15	90-07298	HEXAGON SOCKET SET SCREW CUP POINT KNURLED ISO 4029 TYPE V M4X6 ZM-F-01 REV 03 ZM-L-01 REV 01 NOTE: 2 set screws are needed for an SR motor.	1
16	90-08037	HEXALOBULAR (6 LOBE) SOCKET FLAT HEAD COUNTERSUNK SCREW ISO 14582 M8X30-10.9 ZM-F-01 REV 04 NOTE: Used for both drive side rear motor mount or rear sprocket mounting depending on model. NOTE: Supersedes 90-03223.	1
17	90-02096	MOTOR MOUNTING LEFT FRONT TOP AND LEFT FRONT BOTTOM BOLT	1

18	90-02104	WASHER ISO 7089 -8-200 HV ZM-F-01 REV 02	1
----	----------	--	---

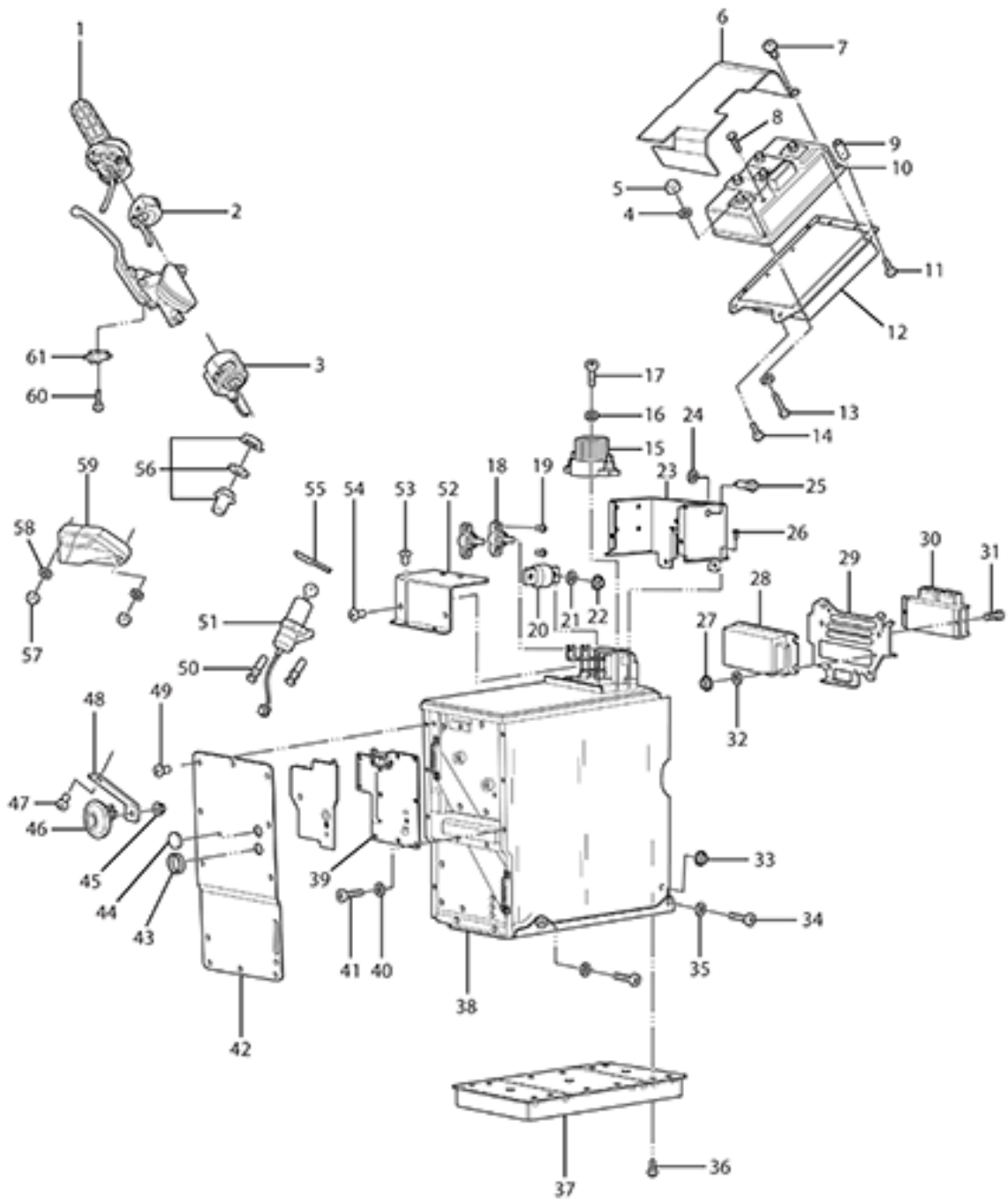

Callout	Part Number	Part Name	Qty. per Motorcycle
1	45-08039	THROTTLE BITRON HALL EFFECT PCB NOTE: Replaced PN 27-08000	1
2	40-06054	KILL MODE START SWITCH	1
3	60-07780	LEFT HAND SWITCHGEAR ECIE	1
4	90-02103	WASHER ISO 7089 6-200HV ZM-F-01 REV 02	1
5	90-02071	HEXAGON NUT ISO 4032 M6-8 ZM-F-01 REV 02	1
6	20-05784	#4 CONTROLLER COVER SHIELDED	1
7	90-06250	CONTROLLER FORMEX PAN HEAD PHILLIPS #6 SHEET METAL SCREW	1
8	90-07063	CONTROLLER LEAD BOLTS M8X16	1
9	20-03823	SDS SEVCON CONTROLLER MOUNT REAR BOLT SPACERS	1
10	60-07007	CONTROLLER SIZE 4 GEN 4 SEVCON NOTE: PLEASE INCLUDE VIN# OF BIKE FOR PROGRAMMING PURPOSES	1
11	90-05843	M8 X 50MM	1
12	20-05300	S/DS/SR HEAT SINK	1
13	90-03251	HEXAGON SOCKET HEAD CAP SCREW ISO 4762 M6X30-8.8 ZM-F-01 REV 03	1
14	90-07268	HEXAGON SOCKET HEAD CAP SCREW ISO 4762 M8X25-10.9 ZM-F-01 REV 03 ZM-L-01 REV 01	1
15	60-06705	CONTACTOR GIGAVAC GX11 12/40VDC COIL	1
16	90-02101	HEADLIGHT MOUNTING WASHER	1
17	90-02116	M5 X 30 MM	1
18	PA-207	FUSE MOUNT 45-04344-1	1
19	PA-208	FUSE MOUNT BOLT 90-07125-19	1
20	45-05224	FUSE 300A 160VDC CLASS T	1
21	PA-209	FUSE WASHER	1
22	45-05240	FUSE NUT INTERNAL	1
23	PA-210	CONTACTOR COVER	1
24	PA-211	LV FUSE WASHER	1
25	PA-212	LV FUSE HOLDER 3101-0125	1
26	PA-213	BATTERY BOX SCREW 90-07124	1
27	90-02054	PREVAILING TORQUE TYPE NUT DIN 985 M6-8 ZM-F-01 REV 02	1
28	60-07190	DC-DC CONV 500W SEVCON 622-11211 ABS UNITS	1
29	20-07736	ELECTRICAL PANEL MOUNT PLATE NOTE: Superseded by 26-08120.	1
30	40-07671	ASSY MBB GENERIC 15MY IMPL NOTE: NOTE: Need to provide motorcycle VIN in shipping notes.	1
31	90-02515	HEXAGON SOCKET HEAD CAP SCREW ISO 4762 M4X12-8.8 ZM-F-01 REV 03	1

32	90-02103	WASHER ISO 7089 6-200HV ZM-F-01 REV 02	1
33	90-03236	PREVAILING TORQUE TYPE NUT DIN 985 M8-10 ZM-F-01 REV 02	1
34	90-02098	HEXAGON SOCKET HEAD CAP SCREW ISO 4762 M8X40-8.8 ZM-F-01 REV 02	1
35	90-02104	WASHER ISO 7089 -8-200 HV ZM-F-01 REV 02	1
36	90-02109	HEXAGON SOCKET BUTTON HEAD CAP SCREW ISO 7380 M5X12-8.8 ZM-F-01 REV 03	1
37	45-08123	CALEX CHARGER ASSEMBLY 1300W REG 10.5 EMC COMPLIANT NOTE: Supersedes 40-08065 and 40-05976.	1
38	46-08034	ASSY BATTERY SDS 4-MOD 16MY IMPL NOTE: Motorcycle VIN#, Case# or Claim# must be provided when ordering. NOTE: Supersedes part number 40-07614. NOTE: NOTE: FOR INSTALLING IN 2014 MODELS, INCLUDE 12-08080 IN THE ORDER. IN CASE OF THE BIKE HAVING A POWER TANK, ALSO INCLUDE 12-08011	1
39	40-08031	BMS PCB ASSY POTTED 17MY IMPL NOTE: PLEASE INCLUDE VIN# OF BIKE AND BATTERY SERIAL # FOR PROGRAMMING PURPOSES NOTE: FOR FX/FXP, IF BATTERY SERIAL NUMBER STARTS WITH 14SG**** PLEASE ORDER 41-06419 NOTE: Super seeded pn:40-07232	1
40	90-02102	WASHER UNIVERSAL (SIZE 1)	1
41	90-05061-3	WIDGET	1
42	20-05252	S/DS/SR BATTERY CASE FRONT	1
43	20-04094	PLUG DIAG PORT 24.50 THRU 26.00 MM 12MY IMPL	1
44	PA-215	BATTERY FRONT UPPER FILLER PLUG 80-08003-1	1
45	90-02054	PREVAILING TORQUE TYPE NUT DIN 985 M6-8 ZM-F-01 REV 02	1
46	45-06774	DISC HORN K70/H12 V WITH BLACK ZINC	1
47	90-02128	HEXAGON SOCKET BUTTON HEAD CAP SCREW ISO 7380 M8X20-8.8 ZM-F-01 REV 03	1
48	20-07073	SDS FRAME MOUNTED HORN BRACKET	1
49	PA-216	BATTERY BOX SCREW 90-07124	1
50	90-02937	M8X14MM BREAK AWAY HEX BOLT NOTE: One Time Use Bolt	1
51	20-05202	KEYSWITCH LOCK AND TANK BAG LOCK COMBO KIT NOTE: This Kit includes an ignition lock (45-02692) and a tank bag/helmet lock (p/n 20-05044) that have been keyed alike with two keys.	1
52	PA-217	BATTERY CONTACTOR TOP COVER 46-08045-1	1
53	PA-218	BATTERY BOX SCREW 90-07124	1
54	PA-219	BATTERY BOX SCREW 90-07125	1

55	20-07062	SDS TRIPLE CLAMP HARNESS SUPPORT	1
56	10-07504	<p>12V ACCESSORY SOCKET KIT - SDS</p> <p>NOTE: Charge a GPS, smart phone or mp3 player using the Zero Motorcycles 12V Accessory Socket Kit. Designed to connect directly to your motorcycle{###}'s power port harness, the accessory socket enables you to charge small devices that have a cigarette lighter plug. The accessory outlet is rated up to 10 amps/120 watts. This kit includes all mounting hardware for installation on the 2014 and later Zero S, Zero DS and Zero SR motorcycles.</p> <p>NOTE: 2014 [Zero SR, Zero S, Zero DS] 2015 [Zero SR, Zero S, Zero DS] 2016-2017 [Zero SR, Zero S, Zero DS, Zero DSR]</p>	1
57	90-02054-1	M6 X 8MM NUT	1
58	90-02103	WASHER ISO 7089 6-200HV ZM-F-01 REV 02	1
59	40-08030	<p>DASH LCD (ABS) BUG LOGO</p> <p>NOTE: Applicable 14MY-16MY</p>	1
60	PA-220	BRAKE LIGHT SWITCH SCREW	1
61	PA-221	<p>BRAKE LIGHT SWITCH</p> <p>NOTE: Not sold separately. Please order the Master Cylinder.</p>	1