

Zero Motocycles
S 2014 Exploded Views

ZEV0001 - Lighting

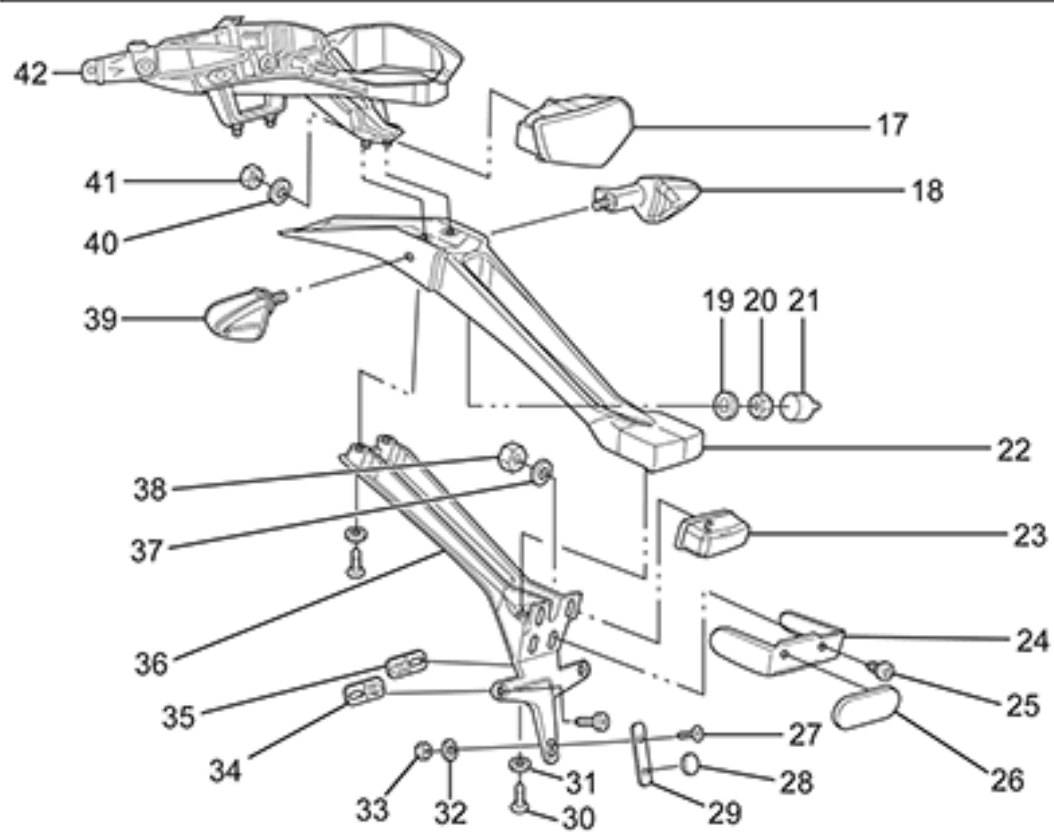
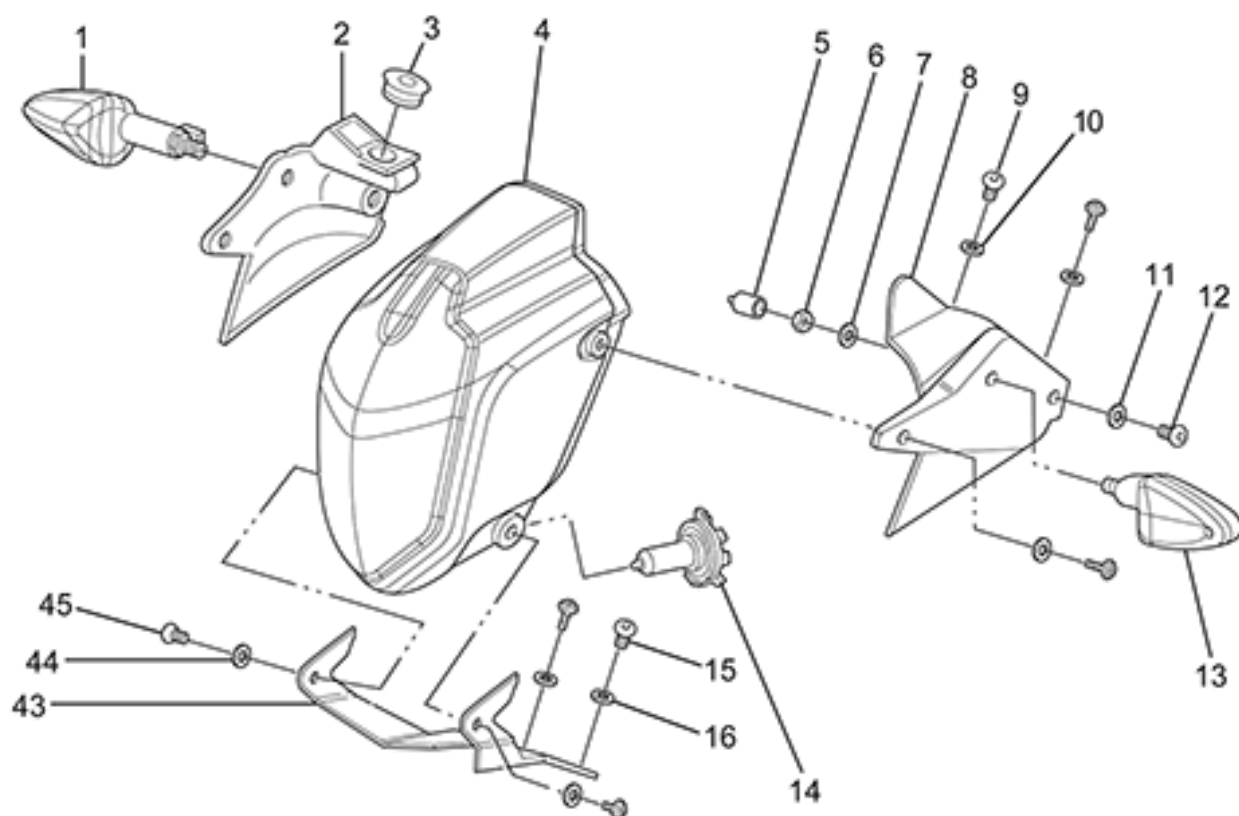

ZEV0001 - Lighting

Callout	Part Number	Part Name	Qty. per Motorcycle
1	65-03462	TURN SIGNAL FR-RH RR-LH	1
2	20-05999	HEADLIGHT MOUNT RIGHT	1
3	20-06938	SDS ACCESSORY OUTLET COVER	1
4	45-03679	HEADLIGHT ASSY, 60/55W, TRIOM	1
5	20-03146	TURN SIGNAL HEX NUT CAP	2
6	90-02072	HEXAGON THIN NUT ISO 4035 M10-04 ZM-F-01 REV 02	2
7	90-02043	TOOTHED LOCK WASHER WITH EXTERNAL TEETH DIN 6797 A M10-B85 ZM-F-01 REV 02	2
8	20-06000	HEADLIGHT MOUNT LEFT	1
9	90-04084	HEXAGON SOCKET BUTTON HEAD CAP SCREW ISO 7380 M5X16-8.8 ZM-F-11 REV 03	4
10	90-04085	WASHER M5 X 11 X 1 NYLON 6/6 BLACK	4
11	90-04085	WASHER M5 X 11 X 1 NYLON 6/6 BLACK	4
12	90-04084	HEXAGON SOCKET BUTTON HEAD CAP SCREW ISO 7380 M5X16-8.8 ZM-F-11 REV 03	4
13	65-03463	TURN SIGNAL FR-LH RR-RH	1
14	65-08002	SDS HEADLIGHT BULB	1
15	90-07281	HEXAGON SOCKET BUTTON HEAD SCREWS ISO 7380 M6X12-8.8 ZM-F-01 REV 03 ZM-L-01 REV 01	2
16	90-02101	HEADLIGHT MOUNTING WASHER	4
17	65-04459	LED TAIL LIGHT TRIOM	1
18	65-03463	TURN SIGNAL FR-LH RR-RH	1
19	90-02043	TOOTHED LOCK WASHER WITH EXTERNAL TEETH DIN 6797 A M10-B85 ZM-F-01 REV 02	2
20	90-02072	HEXAGON THIN NUT ISO 4035 M10-04 ZM-F-01 REV 02	2
21	20-03146	TURN SIGNAL HEX NUT CAP	2
22	24-04439	SDS TAIL POD TOP NOTE: Top half only. Order bottom half PN: 24-05158	1
23	65-04460	LICENSE PLATE LIGHT	1
24	24-05159	REFLECTOR MOUNT BRACKET	1
25	90-05885	PHILIPS HEAD SHEET METAL SCREW 6 X 1/2	10
26	20-03487	REFLECTOR, OVAL, ADH BACK, RED ECIE	1
27	90-05244	HEXAGON SOCKET COUNTERSUNK HEAD SCREW ISO 10642 M5X12-10.9 ZM-F-01 REV 03	4
28	20-05241	LICENSE PLATE BUMPER	1
29	24-05292-1	LICENSE PLATE BRACKET EXTENSIONS NOTE: UR ONLY	1
30	90-07281	HEXAGON SOCKET BUTTON HEAD SCREWS ISO 7380 M6X12-8.8 ZM-F-01 REV 03 ZM-L-01 REV 01	2
31	90-02103	WASHER ISO 7089 6-200HV ZM-F-01 REV 02	10

32	90-04085	WASHER M5 X 11 X 1 NYLON 6/6 BLACK	4
33	90-02053	PREVAILING TORQUE TYPE NUT DIN 985 M5-08 ZM-F-01 REV 02	8
34	24-05161	LICENSE PLATE BRACKET EXTENSIONS NOTE: ONLY USED IN EU/AUS REGIONS	2
35	24-05161	LICENSE PLATE BRACKET EXTENSIONS NOTE: ONLY USED IN EU/AUS REGIONS	2
36	24-05158	SDS TAIL POD BOTTOM NOTE: Bottom half only. Order top half PN: 24-04439	1
37	90-07389	BMS MOUNTING SCREW NEXT TO DIA CONNECTOR	4
38	90-02053	PREVAILING TORQUE TYPE NUT DIN 985 M5-08 ZM-F-01 REV 02	8
39	65-03462	TURN SIGNAL FR-RH RR-LH	1
40	90-02103	WASHER ISO 7089 6-200HV ZM-F-01 REV 02	10
41	90-02054	PREVAILING TORQUE TYPE NUT DIN 985 M6-8 ZM-F-01 REV 02	4
42	20-04876	SDS TAIL FRAME	1
43	20-05910	HEADLIGHT BRACKET	1
44	90-02101	HEADLIGHT MOUNTING WASHER	4
45	90-02545-1	BOLT M6 X 8	1

ZEV0002 - Braking

Callout	Part Number	Part Name	Qty. per Motorcycle
1	10-05717-01	NISSIN FRONT BRAKE LEVER 13/14MY	1
2	25-04796	FR BRAKE MC ASSY 133-M00-94E NISSIN	1
3	25-04796	FR BRAKE MC ASSY 133-M00-94E NISSIN	1
4	PA-2	MASTER CYLINDER CLAMP	1
5	PA-3	MASTER CYLINDER CLAMP BOLT	1
6	25-04796	FR BRAKE MC ASSY 133-M00-94E NISSIN	1
7	PA-5	GASKET	1
8	25-04167	S/XU FR BRAKE LINE ASSY NOTE: 13 and 14MY S and XU. NOTE: Brake line included in assembly will fit 12MY S/XU	1
9	PA-6	GASKET	1
10	PA-7	BANJO BOLT	1
11	90-02545-3	P CLAMP TO TRIPLE CLAMP BOLT	1
12	90-02103	WASHER ISO 7089 6-200HV ZM-F-01 REV 02	10
13	20-01758-1	BRAKE LINE GUIDE	1
14	90-02054	PREVAILING TORQUE TYPE NUT DIN 985 M6-8 ZM-F-01 REV 02	4
15	90-02103	WASHER ISO 7089 6-200HV ZM-F-01 REV 02	10
16	90-02124-1	BUTTON CAP SCREW M6 X 25	1
17	PA-8	BANJO BOLT	1
18	PA-9	GASKET	1
19	PA-10	GASKET	1
20	90-05038-2	M8 X 40 CALIPER MOUNTING BOLT	2
21	25-08051	JJUAN CALIPER/MASTER CYLINDER BLEED SCREW SDS/XMX	1
22	PA-124	CALIPER SLIDE PIN	1
23	PA-12	PIN PLUG	1
24	25-05940-01	13-14MY FRONT BRAKE PAD REPLACEMENT KIT	2
25	25-08021	ANTI SQUEAL SHIM REAR SDS NOTE: Rear Shim Kit fit JJuan Rear Caliper	1
26	25-04164	FR BRAKE CALIPER ASSY 272-C00-363 NISSIN	1
27	90-03477-8	FRONT ROTOR BOLT M6 X 15 NOTE: Superseded by 90-07290.	6
28	25-03541	BRAKE ROTOR ASSY 313 MM FLOATING	1
29	25-05243	REAR MASTER CYLINDER RESERVOIR	1
30	PA-14	WASHER	1
31	90-07273	HEXAGON SOCKET BUTTON HEAD CAP SCREW ISO 7380 M6X16-8.8 ZM-F-01 REV 03 ZM-L-01 REV 01	1
32	25-0714	REAR BRAKE LINE AND SWITCH NOTE: Includes item 33 also	1

33	25-0714	REAR BRAKE LINE AND SWITCH NOTE: Includes item 32 also	1
34	PA-15	GASKET	1
35	PA-16	GASKET	1
36	56-04685	HARNESS GND T CLAMP	1
37	PA-17	BOLT	1
38	PA-18	WASHER	1
39	PA-19	CLAMP	1
40	PA-20	BANJO BOLT	1
41	PA-21	GASKET	1
42	PA-22	GASKET	1
43	25-08050	JJUAN CALIPER PAD PIN SDS/XMX	1
44	12-08010	REAR BRAKE PAD SET WITH SHIMS NOTE: includes 25-08021 shim kit	2
45	PA-24	ANTI-RATTLE CLIP	1
46	PA-25	CALIPER SLIDE BOLT CLIP	1
47	25-04735	RR BRAKE CALIPER ASSY 252-C10-422 NISSIN	1
48	25-07621	BRAKE ROTOR 240MM FIXED WITH COUNTERBORE	1
49	90-07516	REAR BRAKE ROTOR BOLT NOTE: Supersedes 90-08015.	1
50	PA-27	COTTER PIN	1
51	90-02100-2	M10 WASHER	1
52	20-02465	IGLIDE BEARING GFM-1416-06	1
53	90-02124-1	BUTTON CAP SCREW M6 X 25	1
54	20-03110	SPRING X BRAKE PEDAL	1
55	20-02465	IGLIDE BEARING GFM-1416-06	1
56	25-02449	X BRAKE PEDAL	1
57	20-02455	X BRAKE PEDAL SPACER	1
58	20-02465	IGLIDE BEARING GFM-1416-06	1
59	90-07318	HEXAGON FLANGE BOLT DIN 6921 M10X35 10.9 ZM-F-01 REV 03 ZM-L-01 REV 01	1
60	90-02133	1/4 X 3/4 CLEVIS PIN STEEL ZINC	1
61	25-07457	MASTER CYLINDER GUARD FOR J-JUAN MASTER CYLINDER	1
62	PA-28	WASHER	1
63	PA-29	BOLT	1
64	312 91267 001 0 1	REAR MASTER CYLINDER	1

ZEV0003 - Wheel Assy

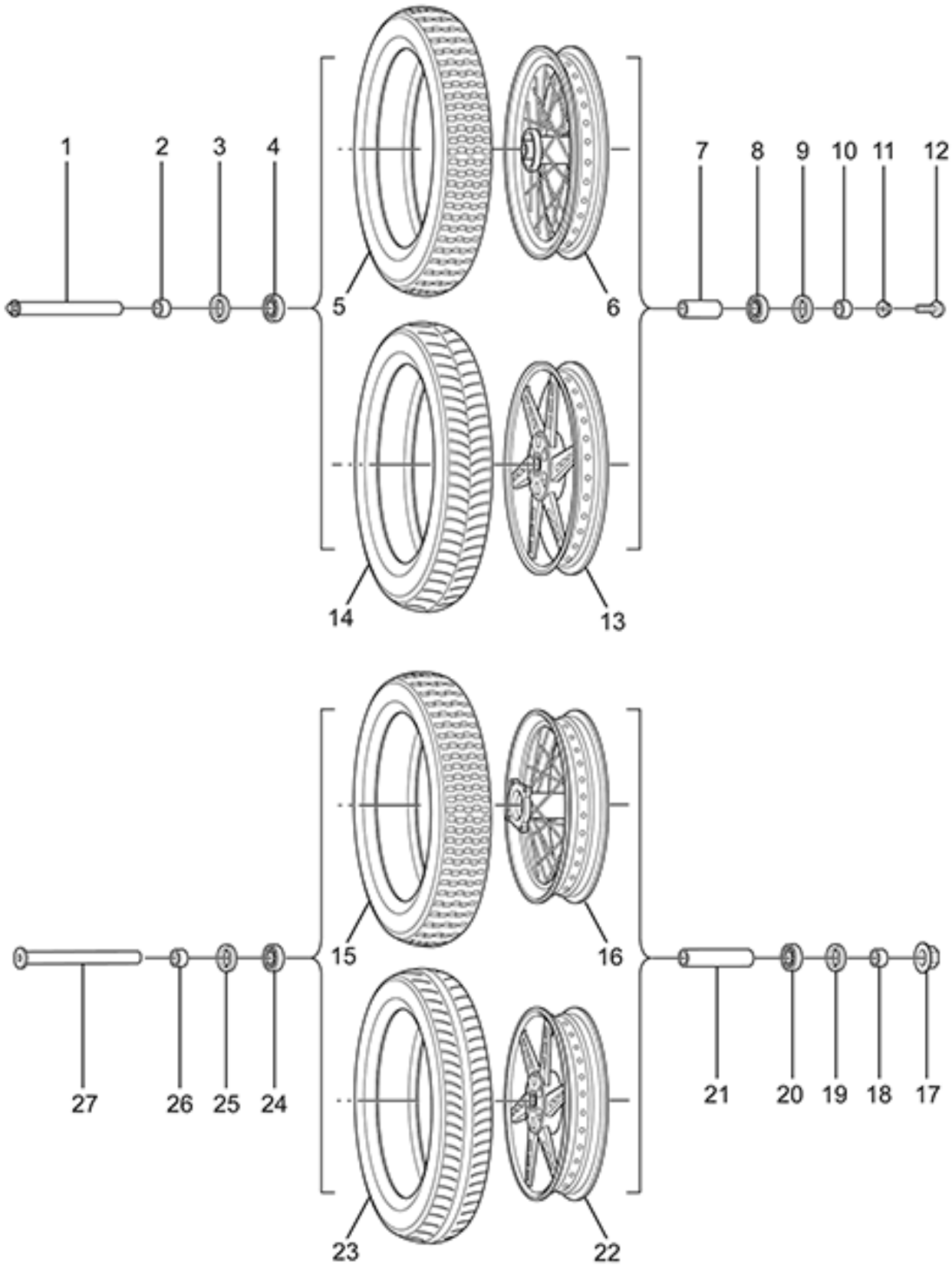

ZEV0003 - Wheel Assy

Callout	Part Number	Part Name	Qty. per Motorcycle
1	23-06388	AXLE FRONT 20MM DIA 232MM LENGTH	1
2	23-02590	SDS FRONT/XMX AXLE SPACER	1
3	23-02626	SHAFT SEAL 25X37X7MM	2
4	20-04119	WHEEL BEARING 6904 2RS	2
5	PA-30	DS FRONT TIRE NOTE: Size 19x100x90	1
6	<i>Not Applicable to this Bike Model</i>		
7	PA-31	INNER BEARING SPACER	1
8	20-04119	WHEEL BEARING 6904 2RS	2
9	23-02626	SHAFT SEAL 25X37X7MM	2
10	23-02590	SDS FRONT/XMX AXLE SPACER	1
11	23-05979	AXLE CAP, 2MM EU EDGE RADIUS	1
12	PA-32	AXLE END CAP BOLT M8 - 1.25 X 20MM	1
13	23-03929-1	3.00X17 S FRONT CAST WHEEL ASSY 13MY IMPL NOTE: Does not apply to DS	1
14	23-03975	IRC RX-01 TIRE, 110/70-17 NOTE: Used on the 2013 and 2014 Zero S as well as the 2014 Zero SR. NOTE: 2015 Spring Tire Sale: Priced reduced from MSRP of \$139.99 and Dealer Price of \$90.99.	1
15	PA-34	DS REAR TIRE NOTE: Size 17x130x80	1
16	<i>Not Applicable to this Bike Model</i>		
17	90-05678	U-NUT M20X1.5 FN 27S 15H (REAR AXLE NUT) NOTE: Rear Axle Nut	1
18	20-07324	SDS REAR WHEEL RIGHT SPACER	1
19	23-02626	SHAFT SEAL 25X37X7MM	2
20	20-04119	WHEEL BEARING 6904 2RS	3
21	PA-35	INNER BEARING SPACER	1
22	23-04859-1	3.50X17 S REAR CAST WHEEL ASSY 13MY IMPL, BLACK	1
23	23-06529	IRC RX-01 TIRE, 140/70-17 NOTE: Used on the 2014 Zero S as well as the 2014 Zero SR. NOTE: 2015 Spring Tire Sale: Priced reduced from MSRP of \$125.00 and Dealer Price of \$81.25.	1
24	20-04119	WHEEL BEARING 6904 2RS	2
25	23-02626	SHAFT SEAL 25X37X7MM	2
26	23-05195	REAR WHEEL SPACER LEFT 13MY IMPL	1
27	23-08032	REAR AXLE 20MM HOLLOW, ROUNDED END	1

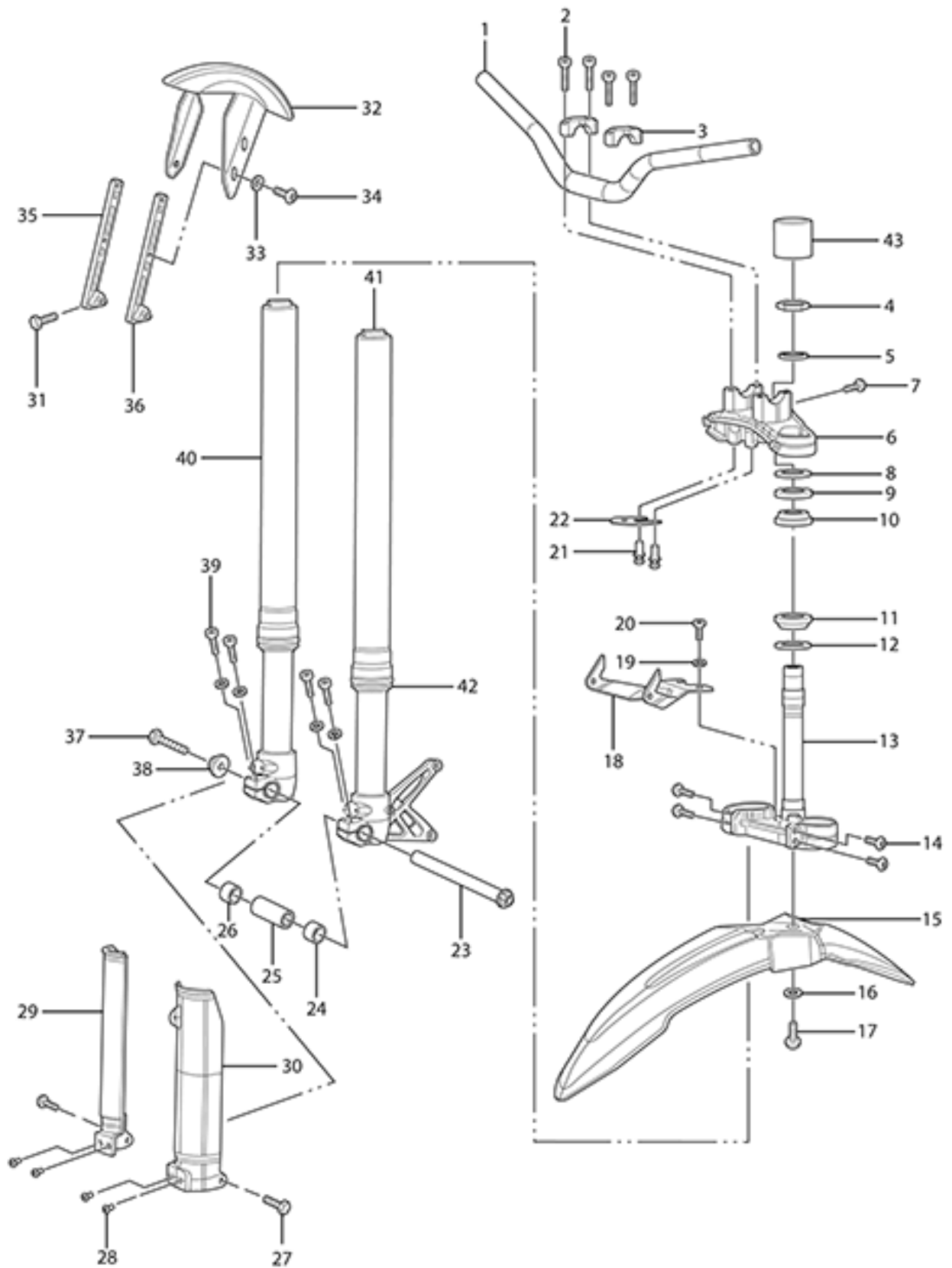

ZEV0004 - Steering Systems

Callout	Part Number	Part Name	Qty. per Motorcycle
1	27-08017	CARRYOVER SPORT HANDLEBAR, NEW LOGO NOTE: Supersedes part 20-07242. Superseded by 27-08049.	1
2	90-02096	MOTOR MOUNTING LEFT FRONT TOP AND LEFT FRONT BOTTOM BOLT	3
3	22-00687	S HANDLEBAR CLAMP	1
4	22-06279	STEERING STEM THIN NUT M27 X 1.5 X 8MM	1
5	20-06278	WASHER 41 - 27.5 X 2 MM	1
6	22-06126	SDS UPPER TRIPLE CLAMP	1
7	90-02094	HEXAGON SOCKET HEAD CAP SCREW ISO 4762 M8X25-10.9 ZM-F-01 REV 03	6
8	22-06257	STEERING STEM LOCK NUT M 30 X1.5 MM	1
9	20-06113	BEARING LIP SEAL OVERMOLDED 55MM OD NOTE: Superseded by 81-08045	2
10	20-06068	STEERING HEAD BEARING KOYO SAC3055-1	2
11	20-06068	STEERING HEAD BEARING KOYO SAC3055-1	2
12	20-06113	BEARING LIP SEAL OVERMOLDED 55MM OD NOTE: Superseded by 81-08045	2
13	22-06128	SDS LOWER TRIPLE CLAMP ASSY	1
14	90-02094	HEXAGON SOCKET HEAD CAP SCREW ISO 4762 M8X25-10.9 ZM-F-01 REV 03	6
15	<i>Not Applicable to this Bike Model</i>		
16	<i>Not Applicable to this Bike Model</i>		
17	<i>Not Applicable to this Bike Model</i>		
18	20-05910	HEADLIGHT BRACKET	1
19	90-02101	HEADLIGHT MOUNTING WASHER	4
20	90-02109	HEXAGON SOCKET BUTTON HEAD CAP SCREW ISO 7380 M5X12-8.8 ZM-F-01 REV 03	8
21	90-02937	M8X14MM BREAK AWAY HEX BOLT NOTE: One Time Use Bolt	2
22	20-07062	SDS TRIPLE CLAMP HARNESS SUPPORT	1
23	23-06388	AXLE FRONT 20MM DIA 232MM LENGTH	1
24	23-02590	SDS FRONT/XMX AXLE SPACER	1
25	PA-37	INNER BEARING SPACER	1
26	23-02590	SDS FRONT/XMX AXLE SPACER	1
27	90-07427	HEXAGON FLANGE BOLT DIN 6921 OR ISO 4162 M6X12 ZM-F-01 REV 03 ZM-L-01 REV 01 NOTE: Does not apply to DS	4
28	PA-38	M6 - 1.00 X 10MM	1
29	<i>Not Applicable to this Bike Model</i>		
30	<i>Not Applicable to this Bike Model</i>		

31	90-07369	HEXAGON SOCKET BUTTON HEAD CAP SCREW ISO 7380 M6X14-8.8 ZM-F-01 REV 03 ZM-L-01 REV 01 NOTE: Does not apply to DS	4
32	24-04436-1	S/XU FRONT FENDER (BLACK #2) NOTE: Does not apply to DS	1
33	90-02105	WASHER ISO 7093-1 6-200 HV ZM-F-01 REV 02	10
34	90-02122	HEXAGON SOCKET BUTTON HEAD CAP SCREW ISO 7380 M6X16-8.8 ZM-F-01 REV 03	1
35	20-06434	FENDER MOUNT BRACKET BOLT NOTE: Does not apply to DS	2
36	20-06434	FENDER MOUNT BRACKET BOLT NOTE: Does not apply to DS	2
37	PA-39	AXLE END CAP BOLT M8 - 1.25 X 20MM	1
38	23-05979	AXLE CAP, 2MM EU EDGE RADIUS	1
39	90-07265	HEXAGON SOCKET HEAD CAP SCREW ISO 4762 M6X20-8.8 ZM-F-01 REV 03 ZM-L-01 REV 01	4
40	22-06864	S/SR FORK SET FASTACE 14MY	1
41	22-06864	S/SR FORK SET FASTACE 14MY	1
42	22-07494	14MY FORK SEAL KIT	1
43	PA-40	STEERING STEM NUT SOCKET	1

ZEV0005 - Body Trim

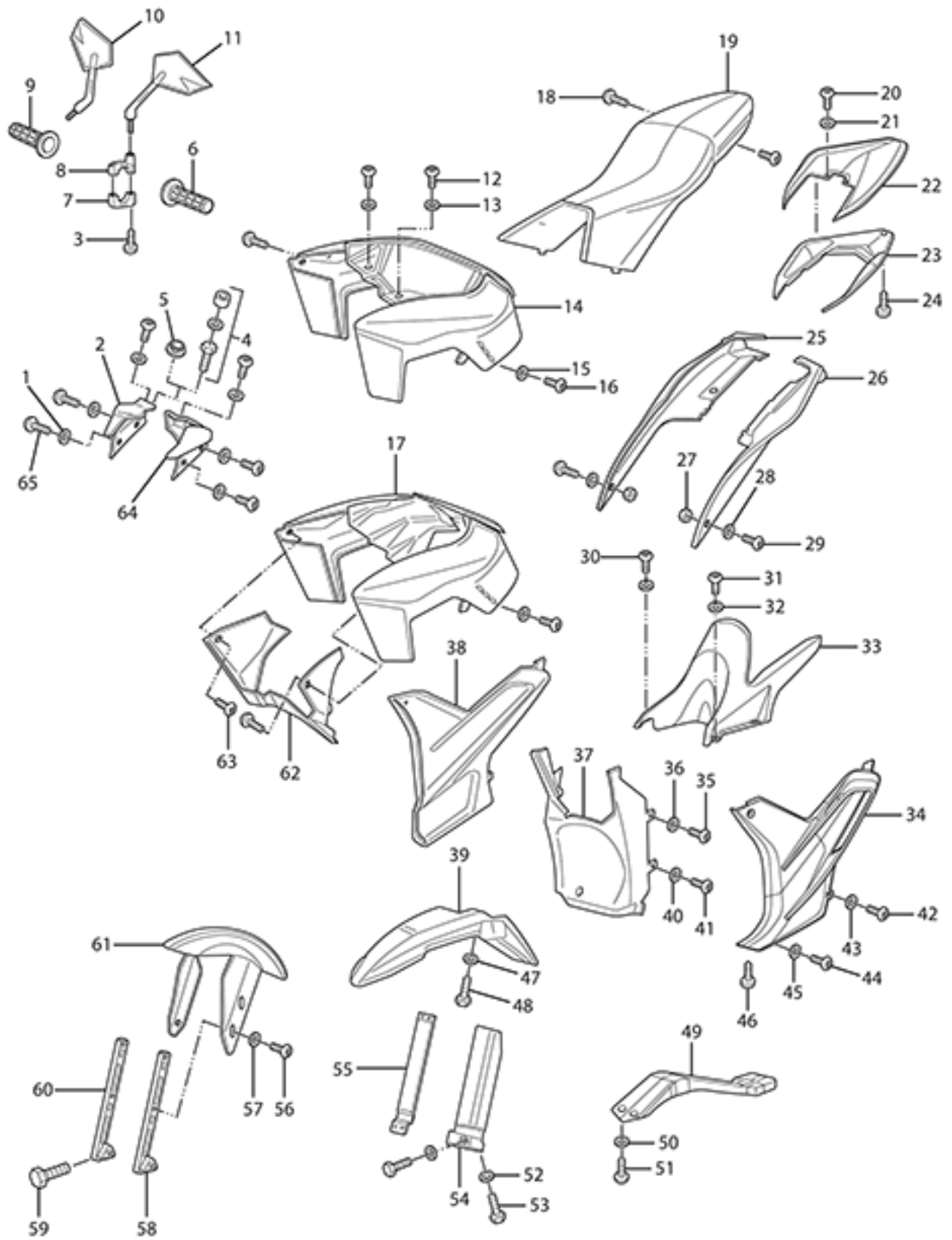

ZEV0005 - Body Trim

Callout	Part Number	Part Name	Qty. per Motorcycle
1	90-04085	WASHER M5 X 11 X 1 NYLON 6/6 BLACK	4
2	20-05999	HEADLIGHT MOUNT RIGHT	1
3	90-07265	HEXAGON SOCKET HEAD CAP SCREW ISO 4762 M6X20-8.8 ZM-F-01 REV 03 ZM-L-01 REV 01	2
4	10-07504	12V ACCESSORY SOCKET KIT - SDS NOTE: Charge a GPS, smart phone or mp3 player using the Zero Motorcycles 12V Accessory Socket Kit. Designed to connect directly to your motorcycle's power port harness, the accessory socket enables you to charge small devices that have a cigarette lighter plug. The accessory outlet is rated up to 10 amps/120 watts. This kit includes all mounting hardware for installation on the 2014 and later Zero S, Zero DS and Zero SR motorcycles. NOTE: 2014 [Zero SR, Zero S, Zero DS] 2015 [Zero SR, Zero S, Zero DS] 2016-2017 [Zero SR, Zero S, Zero DS, Zero DSR]	1
5	20-06938	SDS ACCESSORY OUTLET COVER	1
6	20-04154	GRIP RIGHT	1
7	24-02961	MIRROR MOUNT CLAMP	1
8	24-02913	MIRROR MOUNT BODY LH THREAD	1
9	20-04154	GRIP RIGHT	1
10	24-04159	MIRROR ASSY LONG STEM RIGHT SIDE	1
11	24-04160	MIRROR ASSY LONG STEM LEFT SIDE	1
12	90-04084	HEXAGON SOCKET BUTTON HEAD CAP SCREW ISO 7380 M5X16-8.8 ZM-F-11 REV 03	4
13	90-04085	WASHER M5 X 11 X 1 NYLON 6/6 BLACK	4
14	24-08205-1	S TANK ASSEMBLY BLACK NOTE: Does not apply to SR or Power Tank option NOTE: Does not include tank bag NOTE: replacing old p/n:24-05327-1	1
14	24-08205-7	S TANK ASSEMBLY YELLOW NOTE: Supersedes part number 24-05327-7. Note that the 13MY yellow was different from 14MY and later.	1
15	90-04085	WASHER M5 X 11 X 1 NYLON 6/6 BLACK	4
16	90-04084	HEXAGON SOCKET BUTTON HEAD CAP SCREW ISO 7380 M5X16-8.8 ZM-F-11 REV 03	4
17	20-06668	POWER TANK ASSY, S-BLACK NOTE: Plastic tank assembly for use with a Power Tank on a black Zero S. Does not include bucket for SDS storage bag. NOTE: Superseded by 24-08207-1	1
17	20-06721	WHITE NOTE: Does not apply to SR	1

17	20-06723	POWER TANK ASSY, SR RED NOTE: Superseded by 24-08208-6	1
17	20-06722	14MY S POWER TANK ASSEMBLY YELLOW NOTE: Does not apply to SR	1
18	90-08005	SEAT BOLT M8X55 NOTE: Supersedes 90-07009.	2
19	24-04854	SDS SEAT ASSEMBLY	1
20	PA-41	BOLT	1
21	PA-42	WASHER	1
22	24-04432-1	SDS TAIL TOP BLACK#2	1
23	24-08099	SDS TAIL BOTTOM BLACK/BASE NOTE: 24-08099 Black (unpainted) tail top bottom. Used as the base for the 17MY painted colors.	1
24	90-05885	PHILIPS HEAD SHEET METAL SCREW 6 X 1/2	10
25	24-04434	TRUNK PAN RIGHT	1
26	24-04435	TRUNK PAN LEFT	1
27	PA-43	NUT	1
28	PA-44	WASHER	1
29	PA-45	BOLT	1
30	PA-46	BOLT	1
31	PA-47	BOLT	1
32	PA-48	WASHER	1
33	24-08157	REAR INNER FENDER NOTE: Supersedes part number 24-04438	1
34	24-06684	SDS CHIN FAIRING LEFT NOTE: Please order 80-06733 GRAPHIC LABEL SANTA CRUZ separately.	1
35	90-04084	HEXAGON SOCKET BUTTON HEAD CAP SCREW ISO 7380 M5X16-8.8 ZM-F-11 REV 03	4
36	90-04085	WASHER M5 X 11 X 1 NYLON 6/6 BLACK	4
37	24-07674	SDS STUBBY CHIN CENTER	1
38	24-08235	SDS CHIN FAIRING RIGHT NOTE: Please order 80-06733 GRAPHIC LABEL SANTA CRUZ or 80-08012 CRAFTED IN CALIFORNIA JEWEL. NOTE: Supersedes part number 24-06685.	1
39	<i>Not Applicable to this Bike Model</i>		
40	90-04085	WASHER M5 X 11 X 1 NYLON 6/6 BLACK	4
41	90-04084	HEXAGON SOCKET BUTTON HEAD CAP SCREW ISO 7380 M5X16-8.8 ZM-F-11 REV 03	4
42	90-04084	HEXAGON SOCKET BUTTON HEAD CAP SCREW ISO 7380 M5X16-8.8 ZM-F-11 REV 03	4
43	90-04085	WASHER M5 X 11 X 1 NYLON 6/6 BLACK	4
44	90-04084	HEXAGON SOCKET BUTTON HEAD CAP SCREW ISO 7380 M5X16-8.8 ZM-F-11 REV 03	4
45	90-04085	WASHER M5 X 11 X 1 NYLON 6/6 BLACK	4

46	90-04084	HEXAGON SOCKET BUTTON HEAD CAP SCREW ISO 7380 M5X16-8.8 ZM-F-11 REV 03	4
47	<i>Not Applicable to this Bike Model</i>		
48	<i>Not Applicable to this Bike Model</i>		
49	24-04439	SDS TAIL POD TOP NOTE: Top half only. Order bottom half PN: 24-05158	1
50	90-02103	WASHER ISO 7089 6-200HV ZM-F-01 REV 02	10
51	90-07281	HEXAGON SOCKET BUTTON HEAD SCREWS ISO 7380 M6X12-8.8 ZM-F-01 REV 03 ZM-L-01 REV 01	2
52	PA-49	FORK GUARD WASHER	1
53	<i>Not Applicable to this Bike Model</i>		
54	<i>Not Applicable to this Bike Model</i>		
55	<i>Not Applicable to this Bike Model</i>		
56	90-07292	HEXAGON SOCKET BUTTON HEAD CAP SCREW ISO 7380 M5X16-8.8 ZM-F-11 REV 01 ZM-L-01 REV 01 NOTE: Does not apply to DS	1
57	90-04085	WASHER M5 X 11 X 1 NYLON 6/6 BLACK	4
58	20-06434	FENDER MOUNT BRACKET BOLT NOTE: Does not apply to DS	2
59	20-06434	FENDER MOUNT BRACKET BOLT NOTE: Does not apply to DS	2
60	20-06434	FENDER MOUNT BRACKET BOLT NOTE: Does not apply to DS	2
61	24-04436-1	S/XU FRONT FENDER (BLACK #2) NOTE: Does not apply to DS	1
61	24-04436-3	S/XU FRONT FENDER (YELLOW #1) NOTE: Does not apply to DS	1
62	24-04428	SDS FAIRING FRONT CENTER BLACK#2	1
63	90-05885	PHILIPS HEAD SHEET METAL SCREW 6 X 1/2	10
64	20-06000	HEADLIGHT MOUNT LEFT	1
65	90-04084	HEXAGON SOCKET BUTTON HEAD CAP SCREW ISO 7380 M5X16-8.8 ZM-F-11 REV 03	4

ZEV0006 - Rear Suspension

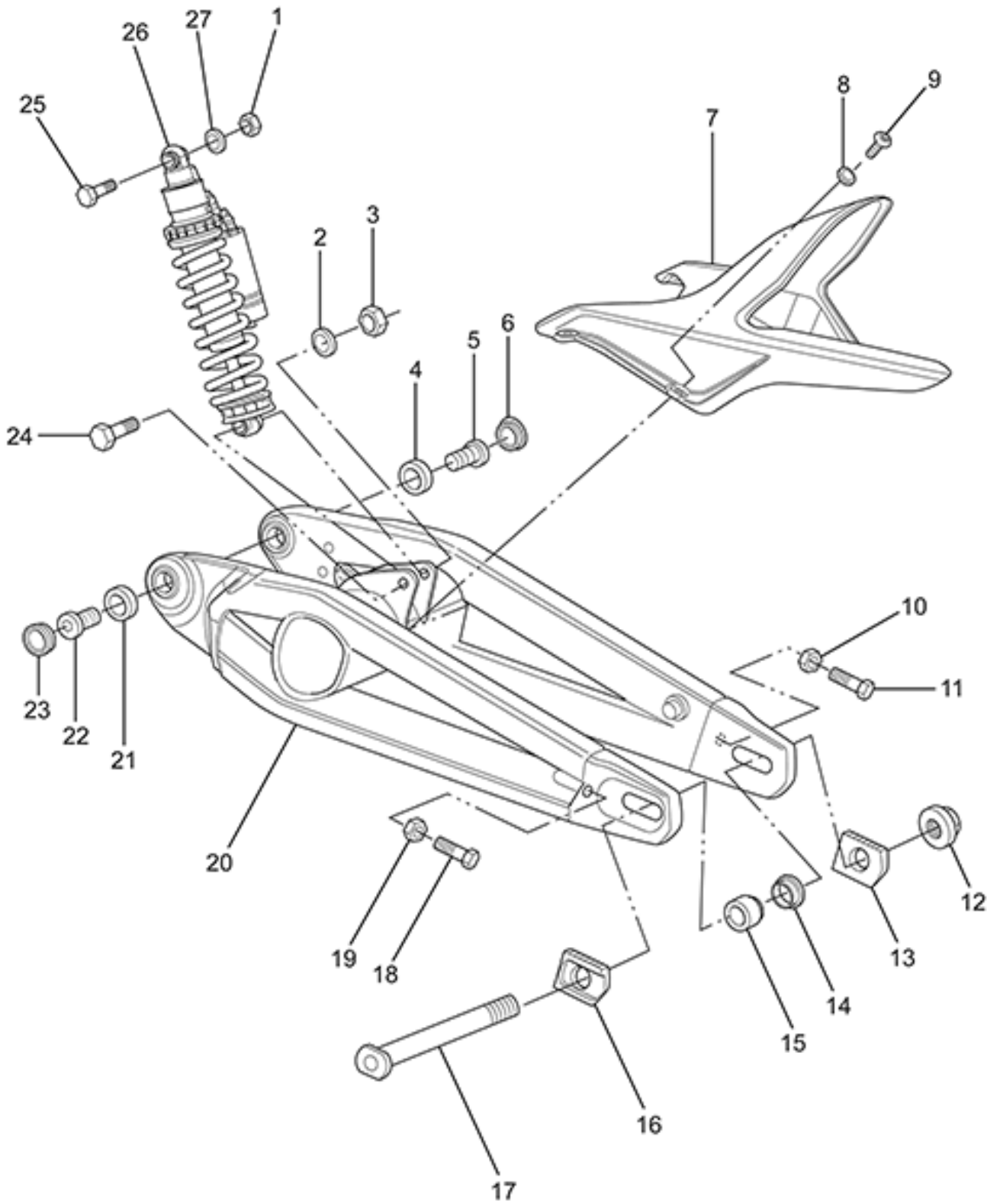

ZEV0006 - Rear Suspension

Callout	Part Number	Part Name	Qty. per Motorcycle
1	90-02050	PREVAILING TORQUE TYPE NUT DIN 985 M10-8 ZM-F-01 REV 02	2
2	90-02100	WASHER ISO 7089 10-200 HV ZM-F-01 REV 02	3
3	90-02050	PREVAILING TORQUE TYPE NUT DIN 985 M10-8 ZM-F-01 REV 02	2
4	20-06138	BEARING 6204 NOTE: Bearing used as swing arm bearing in some models and as the wheel bearing (qty of 5; 2 in front and three in rear wheel) in 2015 and later models. NOTE: Manufacturer part number is 6204-2RS	2
5	20-06130	STUB AXLE	2
6	20-06937	SDS STUB-PIVOT COVER	2
7	24-04438	REAR INNER FENDER NOTE: Superseded by 24-08157	1
8	90-04085	WASHER M5 X 11 X 1 NYLON 6/6 BLACK	4
9	90-02109	HEXAGON SOCKET BUTTON HEAD CAP SCREW ISO 7380 M5X12-8.8 ZM-F-01 REV 03	8
10	90-05088	HEXAGON FLANGE NUT DIN 6923 M8-1.25 ZM-F-01 REV 03	2
11	90-03030	HEXAGON HEAD SCREW DIN 933 M8X40-10.9 ZM-F-01 REV 03	2
12	90-05678	U-NUT M20X1.5 FN 27S 15H (REAR AXLE NUT) NOTE: Rear Axle Nut	1
13	20-04738	REAR AXLE ADJUSTER PUSH BLOCK, NUT SIDE	1
14	20-07324	SDS REAR WHEEL RIGHT SPACER	1
15	23-05195	REAR WHEEL SPACER LEFT 13MY IMPL	1
16	20-04737	REAR AXLE ADJUSTER PUSH BLOCK, HEAD SIDE	1
17	23-04736	AXLE 20MM HOLLOW NOTE: Superseded by pn:23-08032	1
18	90-03030	HEXAGON HEAD SCREW DIN 933 M8X40-10.9 ZM-F-01 REV 03	2
19	90-05088	HEXAGON FLANGE NUT DIN 6923 M8-1.25 ZM-F-01 REV 03	2
20	21-06710-1	S SWINGARM	1
21	20-06138	BEARING 6204 NOTE: Bearing used as swing arm bearing in some models and as the wheel bearing (qty of 5; 2 in front and three in rear wheel) in 2015 and later models. NOTE: Manufacturer part number is 6204-2RS	2
22	20-06130	STUB AXLE	2
23	20-06937	SDS STUB-PIVOT COVER	2
24	90-05711	LOWER SHOCK EYE BOLT M10-1.5X60MM	2

25	90-05711	LOWER SHOCK EYE BOLT M10-1.5X60MM	2
26	22-06861	S/SR SHOCK FASTACE 14MY	1
27	90-02100	WASHER ISO 7089 10-200 HV ZM-F-01 REV 02	3

ZEV0007 - Frame (Left)

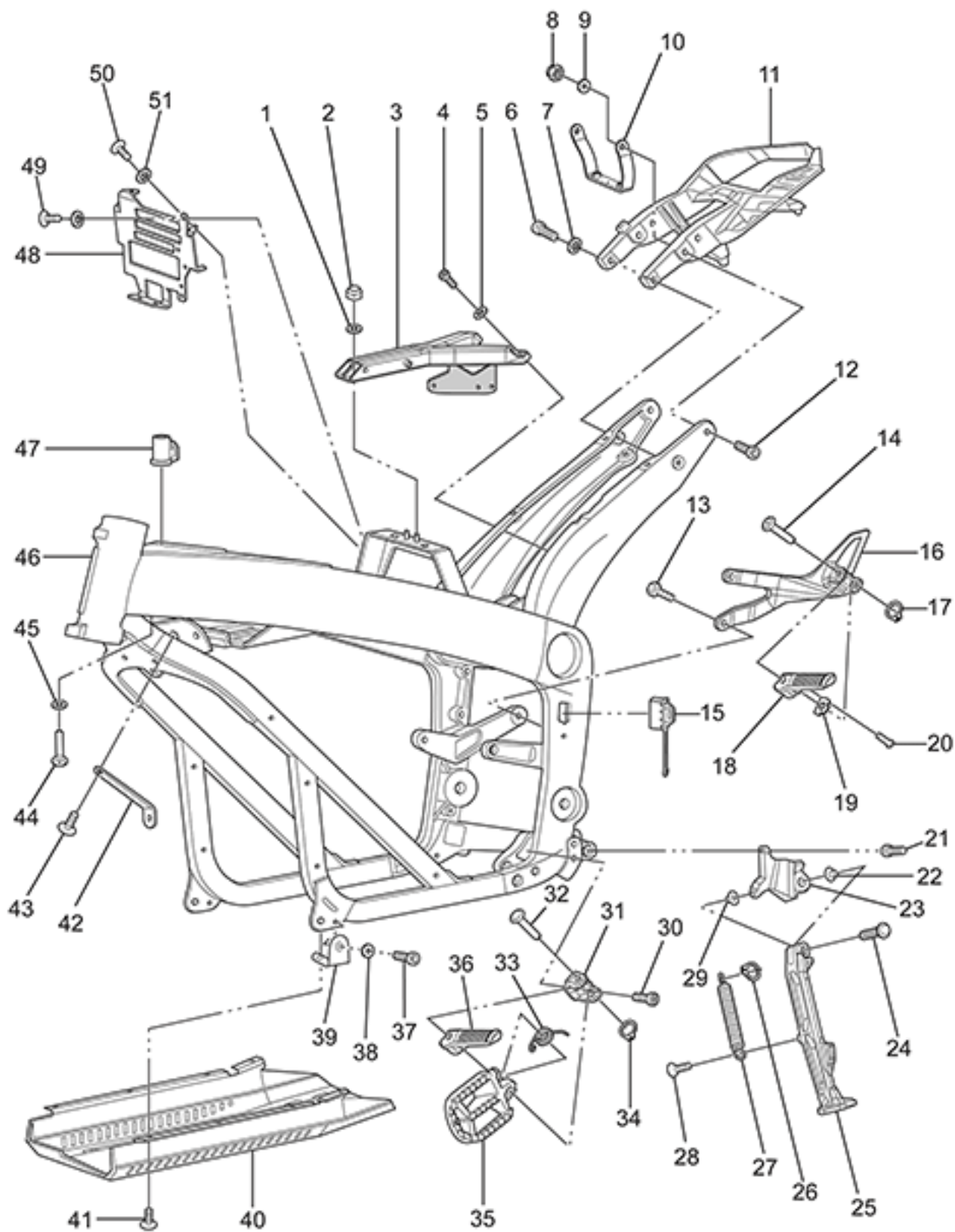

ZEV0007 - Frame (Left)

Callout	Part Number	Part Name	Qty. per Motorcycle
1	90-02103	WASHER ISO 7089 6-200HV ZM-F-01 REV 02	10
2	90-02054	PREVAILING TORQUE TYPE NUT DIN 985 M6-8 ZM-F-01 REV 02	4
3	21-06979	SDS SEAT FRAME WITH FUSEPANEL MOUNT NOTE: Shaded area of the bracket only found on SR	1
4	90-02122	HEXAGON SOCKET BUTTON HEAD CAP SCREW ISO 7380 M6X16-8.8 ZM-F-01 REV 03	1
5	90-02103	WASHER ISO 7089 6-200HV ZM-F-01 REV 02	10
6	90-04103	TAIL FRAME BOLT HEX HEAD 8MM - 1.00 X 30MM	1
7	90-02104	WASHER ISO 7089 -8-200 HV ZM-F-01 REV 02	10
8	90-03236	PREVAILING TORQUE TYPE NUT DIN 985 M8-10 ZM-F-01 REV 02	4
9	90-02104	WASHER ISO 7089 -8-200 HV ZM-F-01 REV 02	10
10	<i>Not Applicable to this Bike Model</i>		
11	20-04876	SDS TAIL FRAME	1
12	90-04103	TAIL FRAME BOLT HEX HEAD 8MM - 1.00 X 30MM	1
13	PA-50	PASSENGER CLEVIS BRACKET BOLT 8MM - 1.25 X 25MM	1
14	90-02725-06	CLEVIS PIN CUSTOM 10MM X 45L	1
15	45-04864	CAVITY PLUG C13	1
16	20-04285	SDS PASSENGER PEG BRKT L	1
17	90-02879	RETAINING RING 9MM SHAFT	1
18	20-05228	FOOTPEG LT PASSENGER	1
19	20-04279	FOOTPEG DETENT PLATE	1
20	20-05404	FOOTPEG DETENT BALL MECHANISM	1
21	90-07277	HEXAGON SOCKET THIN HEAD CAP SCREW DIN 7984 M10X25-8.8 ZM-F-01 REV 03 ZM-L-01 REV 01	4
22	90-02800	BUSHING FLANGE 0.375	2
23	20-06590	KICKSTAND MOUNT	1
24	90-02799	CLEVIS PIN CUSTOM NOTE: Used to attach kickstand leg to mount.	1
25	20-05660	SHORT KICKSTAND LEG W/MAGNET	1
26	90-02837	E CLIP 0.375	2
27	20-00710	S KS SPRING OUT	1
28	90-07261	HEXAGON SOCKET COUNTERSUNK HEAD SCREW ISO 10642 M8X20-10.9 ZM-F-01 REV 03 ZM-L-01 REV 01	2
29	90-02800	BUSHING FLANGE 0.375	2
30	90-07277	HEXAGON SOCKET THIN HEAD CAP SCREW DIN 7984 M10X25-8.8 ZM-F-01 REV 03 ZM-L-01 REV 01	2
31	20-02723	CLEVIS FOOT PEG UNIVERSAL LEFT	1
32	90-02725-06	CLEVIS PIN CUSTOM 10MM X 45L	1

33	20-02727	TORSION SPRING, .678 OD .078 WIRE, CCW	1
34	90-02879	RETAINING RING 9MM SHAFT	1
35	<i>Not Applicable to this Bike Model</i>		
36	20-04305	FOOTPEG LT RIDER	1
37	90-07288	HEXAGON SOCKET HEAD CAP SCREW ISO 4762 M5X12-8.8 ZM-F-01 REV 03 ZM-L-01 REV 01	4
38	PA-51	M5 FLAT WASHER	1
39	20-05307	SKID PAN BRACKET	1
40	20-05126	SDS SKID PAN NOTE: Superseded by part number 26-08051.	1
41	90-02109	HEXAGON SOCKET BUTTON HEAD CAP SCREW ISO 7380 M5X12-8.8 ZM-F-01 REV 03	4
42	20-07073	SDS FRAME MOUNTED HORN BRACKET	1
43	90-02128	HEXAGON SOCKET BUTTON HEAD CAP SCREW ISO 7380 M8X20-8.8 ZM-F-01 REV 03	1
44	90-07281	HEXAGON SOCKET BUTTON HEAD SCREWS ISO 7380 M6X12-8.8 ZM-F-01 REV 03 ZM-L-01 REV 01	2
45	90-02103	WASHER ISO 7089 6-200HV ZM-F-01 REV 02	10
46	21-06708-1	SDS MAIN FRAME NOTE: Does not apply to SR	1
47	20-05202	KEYSWITCH LOCK AND TANK BAG LOCK COMBO KIT NOTE: This Kit includes an ignition lock (45-02692) and a tank bag/helmet lock (p/n 20-05044) that have been keyed alike with two keys.	1
48	20-06932	ELECTRICAL PANEL NO FUSE BOX MOUNT	1
49	PA-52	ELECTRICAL BRACKET BOLT HEX HEAD M5 - 0.80 X 12MM	1
50	PA-53	ELECTRICAL BRACKET BOLT HEX HEAD M5 - 0.80 X 12MM	1
51	PA-54	ELECTRICAL PANEL BOLT WASHER, M5 FLAT WASHER	1

ZEV0008 - Frame (Right)

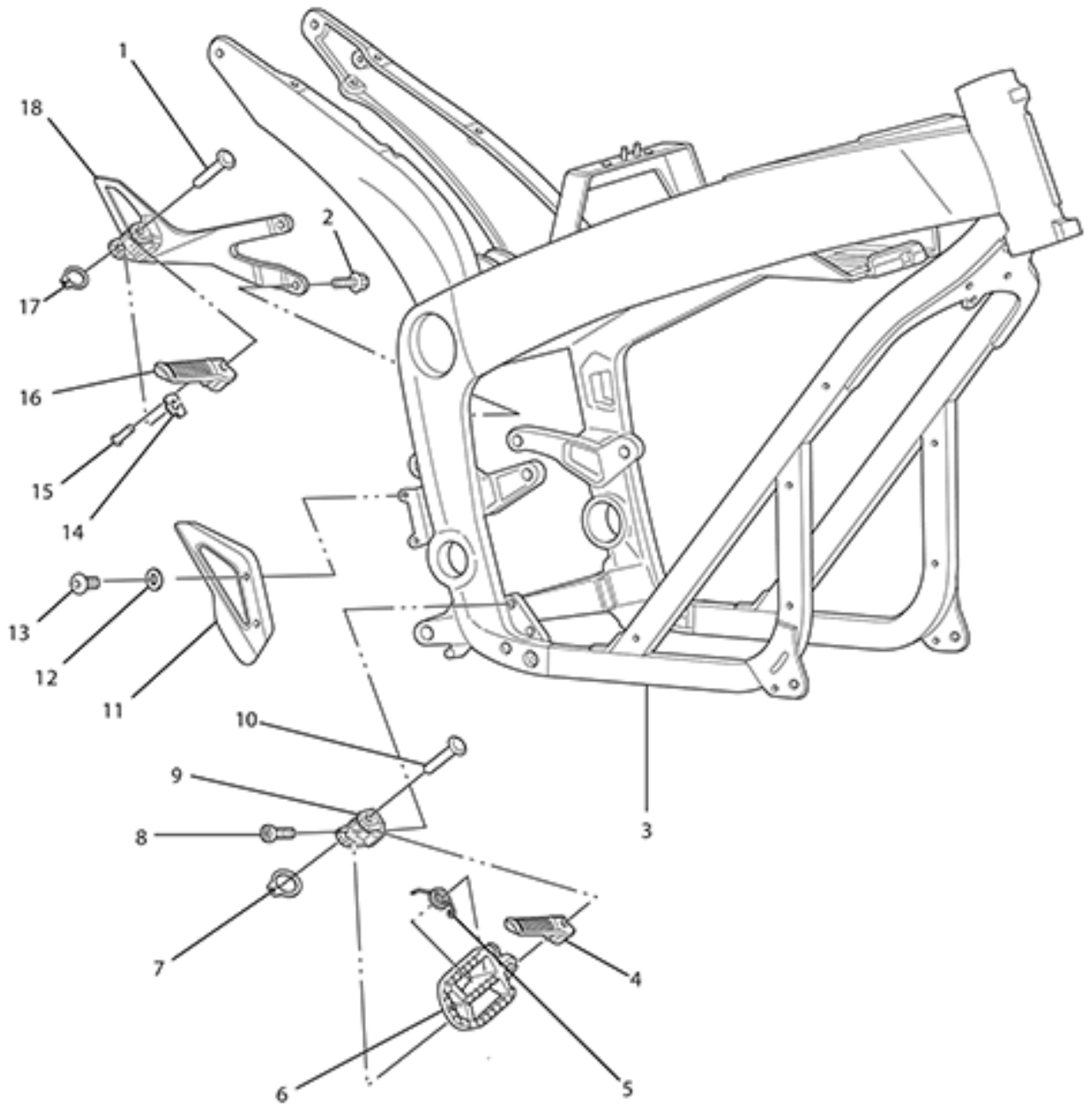

ZEV0008 - Frame (Right)

Callout	Part Number	Part Name	Qty. per Motorcycle
1	90-02725-06	CLEVIS PIN CUSTOM 10MM X 45L	1
2	PA-106	PASSENGER CLEVIS BRACKET BOLT 8MM - 1.25 X 25MM	1
3	21-06708-1	SDS MAIN FRAME NOTE: Does not apply to SR	1
4	20-04304	FOOTPEG RT RIDER NOTE: Does not apply to DS	1
5	20-02727	TORSION SPRING, .678 OD .078 WIRE, CCW	1
6	<i>Not Applicable to this Bike Model</i>		
7	90-02879	RETAINING RING 9MM SHAFT	1
8	90-07277	HEXAGON SOCKET THIN HEAD CAP SCREW DIN 7984 M10X25-8.8 ZM-F-01 REV 03 ZM-L-01 REV 01	2
9	20-02724	CLEVIS FOOT PEG UNIVERSAL RIGHT	1
10	90-02725-06	CLEVIS PIN CUSTOM 10MM X 45L	1
11	25-07457	MASTER CYLINDER GUARD FOR J-JUAN MASTER CYLINDER	1
12	90-02103	WASHER ISO 7089 6-200HV ZM-F-01 REV 02	10
13	90-07323	HEXAGON SOCKET BUTTON HEAD CAP SCREW ISO 7380 M6X25-8.8 ZM-F-01 REV 03 ZM-L-01 REV 01	2
14	20-04279	FOOTPEG DETENT PLATE	1
15	20-05404	FOOTPEG DETENT BALL MECHANISM	1
16	20-05227	FOOTPEG RT PASSENGER	1
17	90-02879	RETAINING RING 9MM SHAFT	1
18	20-04284	SDS PASSENGER PEG BRKT R NOTE: superseded by 20-07604	1

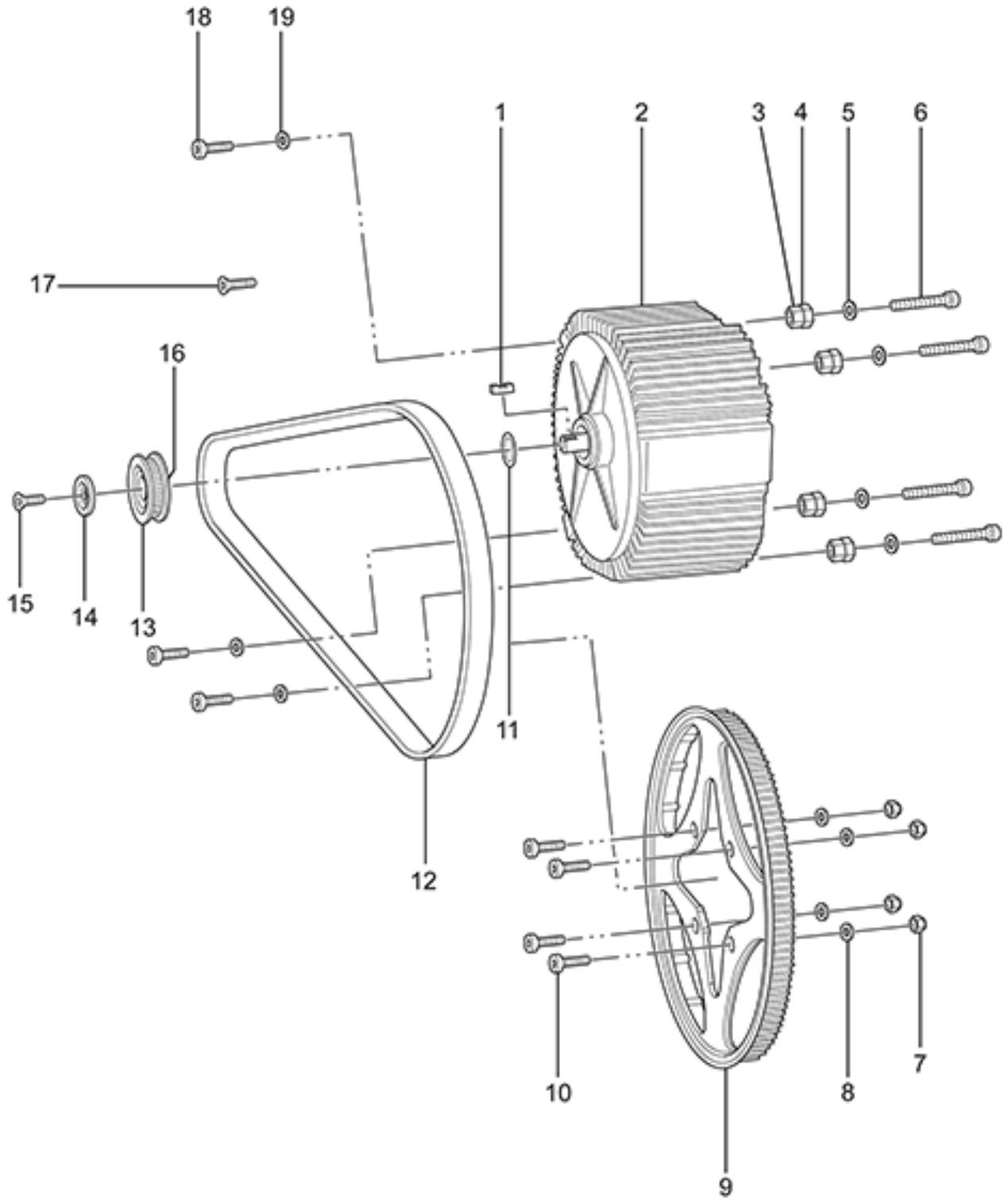

ZEV0009 - Motor and Drive System

Callout	Part Number	Part Name	Qty. per Motorcycle
1	30-06745	SHAFT KEY .25 MOTOR SPROCKET NOTE: Motor Sprocket	1
2	12-08034	ZERO SDS 75-7 MOTOR REPLACEMENT KIT NOTE: Must Provide Warranty Claim and VIN# when ordering NOTE: Must order new bolts Items 15 and 17 NOTE: Old Part# 30-07771	1
3	90-04783	HEXAGON NUT ISO 4033 M14-2 ZM-F-01 REV 03	4
4	20-04774	MOTOR JACK SCREW INNER	1
5	90-02104	WASHER ISO 7089 -8-200 HV ZM-F-01 REV 02	10
6	90-05179	HEXAGON SOCKET HEAD CAP SCREW ISO 4762 M8X60-8.8 ZM-F-01 REV 03	3
7	90-03236	PREVAILING TORQUE TYPE NUT DIN 985 M8-10 ZM-F-01 REV 02	4
8	90-02104	WASHER ISO 7089 -8-200 HV ZM-F-01 REV 02	10
9	30-03672	SPROCKET REAR BELT DRIVE 132T, 8MM PITCH, 17MM WIDE CASTING NOTE: Please order 30-04051	1
9	30-04051	SPROCKET REAR BELT DRIVE 132T, 8MM PITCH, 17MM WIDE FINISHED	1
10	90-03248	HEXAGON SOCKET THIN HEAD CAP SCREW M8X30-8REAR SPROCKET	4
11	30-05502	MOTOR SHAFT SPACER 1.5 MM FOR 1" SHAFT	1
12	30-08084	BELT DRIVE, 220T, 8MM PITCH, 14MM WIDE, NEW LOGO	1
13	30-03657	SPROCKET FRONT, BELT DRIVE 28T, 8MM PITCH, 15MM WIDE 1" BORE NOTE: Does not apply to SR	1
14	20-05453	LOW PROFILE BELT SPROCKET MOTOR SHAFT TOPHAT	1
15	90-02056	HEXAGON SOCKET COUNTERSUNK HEAD SCREW M10X25-8.8 MOTOR SHAFT NOTE: Bolt used to hold front sprocket in place onto the motor shaft. NOTE: Sprocket	1
16	90-07298	HEXAGON SOCKET SET SCREW CUP POINT KNURLED ISO 4029 TYPE V M4X6 ZM-F-01 REV 03 ZM-L-01 REV 01 NOTE: 2 set screws are needed for an SR motor.	1
17	90-08037	HEXALOBULAR (6 LOBE) SOCKET FLAT HEAD COUNTERSUNK SCREW ISO 14582 M8X30-10.9 ZM-F-01 REV 04 NOTE: Used for both drive side rear motor mount or rear sprocket mounting depending on model. NOTE: Supersedes 90-03223.	2

18	90-02096	MOTOR MOUNTING LEFT FRONT TOP AND LEFT FRONT BOTTOM BOLT	3
19	90-02104	WASHER ISO 7089 -8-200 HV ZM-F-01 REV 02	10

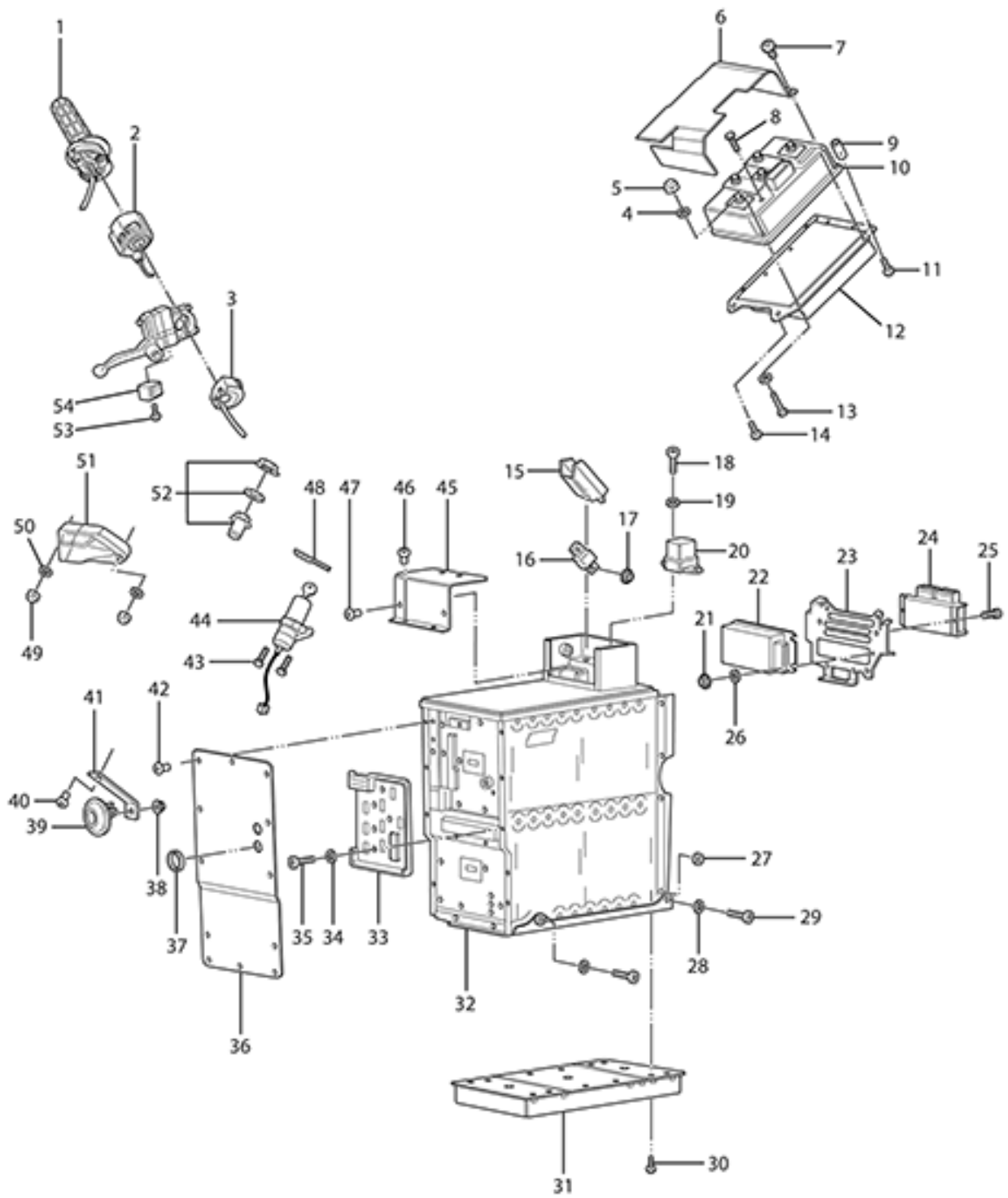

ZEV0010 - Electronics

Callout	Part Number	Part Name	Qty. per Motorcycle
1	40-04069	ASSY THROTTLE 0-5K 4WY	1
2	40-06054	KILL MODE START SWITCH	1
3	45-02693	HANDLEBAR SWITCH L	1
4	90-02103	WASHER ISO 7089 6-200HV ZM-F-01 REV 02	10
5	90-02071	HEXAGON NUT ISO 4032 M6-8 ZM-F-01 REV 02	1
6	20-05784	#4 CONTROLLER COVER SHIELDED	1
7	90-06250	CONTROLLER FORMEX PAN HEAD PHILLIPS #6 SHEET METAL SCREW	4
8	90-07063	CONTROLLER LEAD BOLTS M8X16	5
9	20-03823	SDS SEVCON CONTROLLER MOUNT REAR BOLT SPACERS	1
10	60-07007	CONTROLLER SIZE 4 GEN 4 SEVCON NOTE: PLEASE INCLUDE VIN# OF BIKE FOR PROGRAMMING PURPOSES	1
11	90-05843	M8 X 50MM	1
12	20-05300	S/DS/SR HEAT SINK	1
13	90-03251	HEXAGON SOCKET HEAD CAP SCREW ISO 4762 M6X30-8.8 ZM-F-01 REV 03	10
14	90-07268	HEXAGON SOCKET HEAD CAP SCREW ISO 4762 M8X25-10.9 ZM-F-01 REV 03 ZM-L-01 REV 01	2
15	20-05273	DOG HOUSE FORMEX (FUSE COVER)	1
16	45-05224	FUSE 300A 160VDC CLASS T	1
17	45-05240	FUSE NUT INTERNAL	1
18	90-02116	M5 X 30 MM	1
19	90-02101	HEADLIGHT MOUNTING WASHER	4
20	60-06705	CONTACTOR GIGAVAC GX11 12/40VDC COIL	1
21	90-02054	PREVAILING TORQUE TYPE NUT DIN 985 M6-8 ZM-F-01 REV 02	12
22	60-04015	DC-DC CONV SEVCON 622-11202 NON-EMC	1
23	20-06932	ELECTRICAL PANEL NO FUSE BOX MOUNT	1
24	40-06462	ASSY MBB GENERIC 14MY IMPL NOTE: Please provide motorcycle VIN# and/or Case number for programming at Zero Motorcycles.	1
25	90-02515	HEXAGON SOCKET HEAD CAP SCREW ISO 4762 M4X12-8.8 ZM-F-01 REV 03	2
26	90-02103	WASHER ISO 7089 6-200HV ZM-F-01 REV 02	10
27	90-03236	PREVAILING TORQUE TYPE NUT DIN 985 M8-10 ZM-F-01 REV 02	4
28	90-02104	WASHER ISO 7089 -8-200 HV ZM-F-01 REV 02	10
29	90-02098	HEXAGON SOCKET HEAD CAP SCREW ISO 4762 M8X40-8.8 ZM-F-01 REV 02	2

30	90-02109	HEXAGON SOCKET BUTTON HEAD CAP SCREW ISO 7380 M5X12-8.8 ZM-F-01 REV 03	3
31	45-08123	CALEX CHARGER ASSEMBLY 1300W REG 10.5 EMC COMPLIANT NOTE: Supersedes 40-08065 and 40-05976.	1
32	46-08034	ASSY BATTERY SDS 4-MOD 16MY IMPL NOTE: Motorcycle VIN#, Case# or Claim# must be provided when ordering. NOTE: Supersedes part number 40-07614. NOTE: NOTE: FOR INSTALLING IN 2014 MODELS, INCLUDE 12-08080 IN THE ORDER. IN CASE OF THE BIKE HAVING A POWER TANK, ALSO INCLUDE 12-08011	1
32	46-08033	ASSY BATTERY SDS 3-MOD 16MY IMPL NOTE: Motorcycle VIN#, Case# or Claim# must be provided when ordering. NOTE: Supersedes part number 40-06853. NOTE: NOTE: FOR INSTALLING IN 2014 MODELS, INCLUDE 12-08080 IN THE ORDER. IN CASE OF THE BIKE HAVING A POWER TANK, ALSO INCLUDE 12-08011	1
33	41-06419-08	14MY BMS MODULE NOTE: PLEASE INCLUDE VIN# OF BIKE AND BATTERY SERIAL # FOR PROGRAMMING PURPOSES	1
34	90-02102	WASHER UNIVERSAL (SIZE 1)	10
35	90-05061-3	WIDGET	1
36	20-05252	S/DS/SR BATTERY CASE FRONT	1
37	20-04094	PLUG DIAG PORT 24.50 THRU 26.00 MM 12MY IMPL	1
38	90-02054	PREVAILING TORQUE TYPE NUT DIN 985 M6-8 ZM-F-01 REV 02	1
39	45-06774	DISC HORN K70/H12 V WITH BLACK ZINC	1
40	90-02128	HEXAGON SOCKET BUTTON HEAD CAP SCREW ISO 7380 M8X20-8.8 ZM-F-01 REV 03	1
41	20-07073	SDS FRAME MOUNTED HORN BRACKET	1
42	PA-55	POWER PACK FRONT COVER BOLT M5 X 6MM	1
43	90-02937	M8X14MM BREAK AWAY HEX BOLT NOTE: One Time Use Bolt	2
44	20-05202	KEYSWITCH LOCK AND TANK BAG LOCK COMBO KIT NOTE: This Kit includes an ignition lock (45-02692) and a tank bag/helmet lock (p/n 20-05044) that have been keyed alike with two keys.	1
45	PA-56	POWER PACK TOP COVER	1
46	PA-57	POWER PACK TOP COVER BOLT	1
47	PA-58	POWER PACK TOP COVER BOLT	1
48	20-07062	SDS TRIPLE CLAMP HARNESS SUPPORT	1
49	90-02054-1	M6 X 8MM NUT	12
50	90-02103	WASHER ISO 7089 6-200HV ZM-F-01 REV 02	10

51	40-08030	DASH LCD (ABS) BUG LOGO NOTE: Applicable 14MY-16MY	1
52	10-07504	12V ACCESSORY SOCKET KIT - SDS NOTE: Charge a GPS, smart phone or mp3 player using the Zero Motorcycles 12V Accessory Socket Kit. Designed to connect directly to your motorcycle{###}'s power port harness, the accessory socket enables you to charge small devices that have a cigarette lighter plug. The accessory outlet is rated up to 10 amps/120 watts. This kit includes all mounting hardware for installation on the 2014 and later Zero S, Zero DS and Zero SR motorcycles. NOTE: 2014 [Zero SR, Zero S, Zero DS] 2015 [Zero SR, Zero S, Zero DS] 2016-2017 [Zero SR, Zero S, Zero DS, Zero DSR]	1
53	PA-59	BRAKE SWITCH SCREW	1
54	PA-60	BRAKE SWITCH NOTE: Not sold separately. Please order the Master Cylinder.	1